

TM 10-4320-346-12&P

TECHNICAL MANUAL

OPERATOR'S MANUAL AND UNIT MAINTENANCE MANUAL
INCLUDING REPAIR PARTS AND SPECIAL TOOLS LIST (RPSTL)
FOR

FORWARD AREA WATER POINT SUPPLY SYSTEM (FAWPSS)

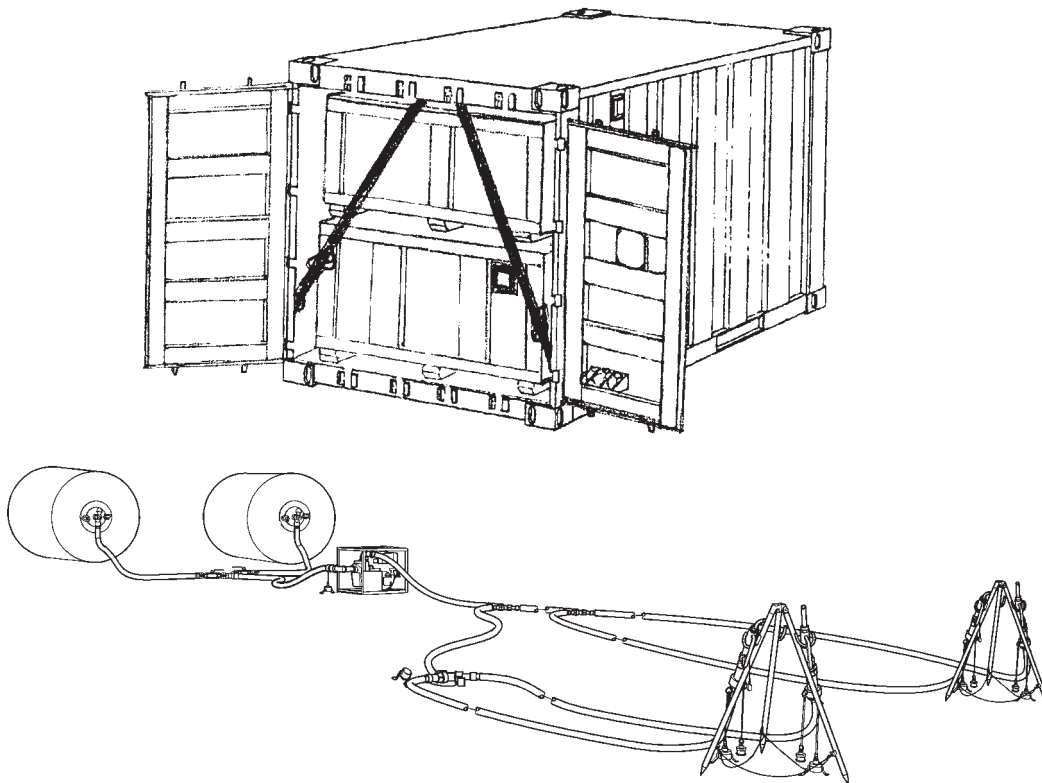

MODEL LAB 9095
(NSN 4320-01-359-0369) (EIC ZFW)

MODEL M105
(NSN 4320-01-532-7057)

*TM 10-4320-346-12&P dated 16 March 2007 supersedes TM 10-4320-346-12&P dated 30 April 1993, including all changes.
DISTRIBUTION STATEMENT A. Approved for public release; distribution is unlimited.

HEADQUARTERS, DEPARTMENT OF THE ARMY

MARCH 2007

WARNING SUMMARY

EXHAUST GASES CAN KILL. Never operate the centrifugal pump engine in an enclosed area unless exhaust gases are piped to the outside. Engine exhaust gases contain carbon monoxide, a colorless, odorless, and poisonous gas that can cause unconsciousness and death if inhaled. **THE BEST DEFENSE AGAINST CARBON MONOXIDE POISONING IS ADEQUATE VENTILATION.** If you experience any of the following symptoms, get out into fresh air immediately: dizziness, intense headache, weakness, sleepiness, muscular twitching, throbbing in temples, or vomiting. Failure to comply may result in injury or death to personnel.

Cleaning solvent compound Skysol 100 solvent is combustible; **DO NOT** use or store near heat, sparks, flame, or other ignition sources. Use mechanical ventilation whenever product is used in a confined space, heated above ambient temperatures, or agitated. Keep container sealed when not in use.

Contact with Skysol 100 may cause skin irritation; use chemical-resistant gloves. In case of skin contact, remove any contaminated clothing and wash skin thoroughly with soap and water. Wash contaminated clothing before reuse. Eye contact may cause irritation, tearing, or blurring of vision. Use face shield or goggles when eye contact may occur. In case of eye contact flush eyes with large amounts of water for at least 15 minutes or until irritation subsides. Inhalation may cause irritation to upper respiratory passages. **DO NOT** have food or drink in the vicinity. Failure to comply may result in injury to personnel.

Do not fill fuel tank while engine is running. Gasoline spilled on a hot engine may explode and serious injury to personnel may result.

Observe all warnings, cautions, and notes while performing Preventive Maintenance Checks and Services (PMCS). Failure to comply may result in damage to equipment and possible injury to personnel.

Ensure parking brake is set and wheels are chocked immediately after parking HEMTT. Failure to comply may result in unexpected movement and possible injury or death to personnel or damage to equipment.

During normal operation the exhaust muffler will become very hot. Exercise caution not to make body contact or touch hot exhaust components with bare hands. Failure to comply may result in severe burns to personnel.

All personnel must stand clear of HEMTT when unloading and loading Flatrack. Failure to comply may result in injury or death to personnel.

Compressed air used for cleaning must not exceed 30 psi (207 kpa). Wear goggles/face shield and gloves when cleaning with compressed air. Failure to comply may result in injury to personnel.

When lifting or maneuvering heavy equipment, ensure sufficient personnel are on hand to do the job. Use proper physical lifting procedures, wear protective equipment such as gloves and steel-toed shoes, and if necessary, use a dolly or suitable lifting device to save time and effort. Failure to comply may result in damage to equipment and possible injury to personnel.

Drums used with FAWPSS Model LAB 9095 will be secured to ground by either banking soil along the sides of each drum, tying them to a secure structure such as a tree or vehicle, or staking them to the ground with rope. All personnel will stand clear of drums until properly secured or injury or death to personnel may result.

For operation of FAWPSS Model M105, drums will be drained sequentially from rear to front of platform during operation. This requirement is to optimize weight distribution for loading and movement of PLS Flatrack or CROP. Failure to comply may result in damage to equipment or possible injury to personnel.

Hearing protection must be worn by all personnel within 20 ft (6.1 m) of an operating pump or long-term hearing loss may result.

When dispensing water for the first time after assembly, operate each nozzle for 30 seconds to flush out any dirt or debris that may have entered the system during assembly. Contaminated water may result in illness to personnel.

Always replace dust cap on end of nozzle spout to keep dirt and debris out. Contaminated water may result in illness to personnel.

To prevent contamination, leave nozzles hooked to stands when disconnecting hoses. Contamination may result in illness to personnel.

Pump unit engine and exhaust system may be hot enough to cause burns if touched. Use caution when shutting off engine or injury to personnel may result.

Hazards to personnel and equipment are increased if the FAWPSS is utilized when site conditions are undesirable or not properly prepared. The site must be inspected and properly prepared prior to setup and operation. Failure to adequately prepare the site could result in damage to equipment or possible injury to personnel.

Ensure all quick-disconnect coupling caps and plugs remain on major components, hoses, and fittings until they are connected into the system. Failure to comply may result in contamination entering system and possible injury to personnel.

WARNING SUMMARY (Contd)

If PLS Flatrack or CROP containing storage drums will be repositioned at the site or removed for refilling of drums, FAWPSS equipment must be cleared from vehicle path and all personnel must stand clear or damage to equipment and possible injury or death to personnel may result.

Ensure coupler valves are protected from contamination when removed from drum. Ensure plastic protective dust caps are installed on both adapter assemblies of drum to prevent contamination and damage to mating surfaces. Failure to comply may result in damage to equipment or possible injury to personnel.

Do not attempt to position, fill, or tiedown drums with PLS Flatrack or CROP loaded on truck. Failure to comply may result in damage to equipment or injury to personnel.

Ensure all non-essential personnel are clear of drums when positioning them during tiedown. Failure to comply may result in injury to personnel.

Only the chain tiedown assemblies from the FAWPSS tiedown kit will be used to secure drums. Failure to comply may result in damage to equipment or injury to personnel.

Do not crisscross chain tiedown straps or drums will become loose during movement. Failure to comply may result in damage to equipment or possible injury to personnel.

Unless adjustment of tiedowns can be performed by operator while standing on ground, unload platform to ground prior to tightening tiedowns to prevent possible falls from elevated platform. Failure to comply may result in injury to personnel.

Always wear gloves to protect hands when handling tiedown chain assemblies and tiedown straps. Failure to comply may result in injury to personnel.

Drums weigh up to 4,300 lb (1,952 kg). Use caution when removing chain tiedown assemblies or injury to personnel may result.

A partially full drum will allow motion of water due to forces resulting from transport. Never transport with more than one partially filled drum. Ensure remaining two drums are either full or as empty as they can be pumped out. Failure to comply may result in damage to equipment or possible injury to personnel.

Use the protective hood supplied with drum kit to protect eyes and face prior to installing a plug assembly. Failure to comply may result in injury to personnel.

Always wear gloves when handling FAWPSS equipment at below freezing temperatures to prevent frost bite. Water can freeze very quickly and freeze skin to equipment on contact. Prevent water from contacting bare skin by always wearing winter gloves or arctic mittens. Failure to comply may result in injury to personnel.

Water contaminated with dust or sand can severely affect the usability of the water. Ensure all hoses, valves, and fittings are clean before connecting, and immediately capped or plugged after disconnecting. Failure to comply may result in damage to equipment and injury to personnel.

FAWPSS drums are authorized to be filled with potable drinking water only. If it is suspected that a drum has been used for holding any liquid other than potable water, do not use water or drum. Failure to comply may result in sickness or death to personnel.

Operators are authorized to remove and replace damaged or malfunctioning FAWPSS component assemblies only. No tools other than those provided in the BII are authorized for operator use. Do not attempt to make adjustments or repairs to any individual component or assembly. Send all defective items to unit maintenance. Failure to comply may result in damage to equipment and possible injury to personnel.

To prevent contamination, move hose assembly to a clean location prior to washing out inside of hose and couplings. Failure to comply may result in injury to personnel.

To prevent contamination, move ball valve assembly to a clean location prior to washing out inside of valve and coupling halves. Failure to comply may result in injury to personnel.

To prevent contamination, dust cap and plug must be installed on nozzle assembly prior to cleaning exterior surfaces of assembly. Never use solvents on inside surfaces of nozzle assembly. Failure to comply will result in contamination and possible injury to personnel.

Improper cleaning methods and use of unauthorized cleaning solvents may result in damage to equipment or possible injury to personnel.

Do not lift a load greater than the rated load capacity of the crane or materiel handling equipment. Failure to comply may result in damage to equipment or possible injury or death to personnel.

All personnel must stand clear of equipment during lifting operations or serious injury or death to personnel may result.

WARNING SUMMARY (Contd)

This drum is only authorized to be filled with DRINKING WATER. The drum is designed and permanently labeled for use with DRINKING WATER ONLY. Filling drum with any other liquid may result in sickness or death to personnel.

Check whether drum has been used with any liquid other than drinking water. Failure to check drum could lead to sickness or death. If there is any question about the quality of the water, do not use water or drum.

Dirt, dust, or foreign matter may contaminate drinking water causing sickness or death to personnel.

Water from FAWPSS must be tested IAW TB MED 577 before use. Failure to comply may result in sickness or death to personnel.

Ensure drum is securely positioned to avoid slipping or rolling during filling operations. Failure to comply may result in damage to equipment or injury to personnel.

LIST OF EFFECTIVE PAGES/WORK PACKAGES

NOTE: This manual supercedes TM 10-4320-346-12&P dated 30 April 1993. Zero in the “Change No.” column indicates an original page or work package.

Dates of issue for original manual is:

Original 0 16 March 2007

TOTAL NUMBER OF PAGES FOR FRONT AND REAR MATTER IS 30 AND TOTAL NUMBER OF WORK PACKAGES IS 51, CONSISTING OF THE FOLLOWING:

WP No.	Change No.	WP No.	Change No.
Cover0	WP 0024 (4 pgs)0
Warning a – c0	WP 0025 (4 pgs)0
Warning d blank0	WP 0026 (4 pgs)0
i – iii0	WP 0027 (4 pgs)0
iv blank0	WP 0028 (4 pgs)0
v and vi0	Chp 6 title page0
Chp 1 title page0	WP 0029 (2 pgs)0
WP 0001 (4 pgs)0	WP 0030 (8 pgs)0
WP 0002 (12 pgs)0	Chp 7 title page0
WP 0003 (2 pgs)0	WP 0031 (5 pgs)0
Chp 2 title page0	WP 0032 (2 pgs)0
WP 0004 (8 pgs)0	WP 0033 (2 pgs)0
WP 0005 (6 pgs)0	WP 0034 (2 pgs)0
WP 0006 (2 pgs)0	WP 0035 (2 pgs)0
WP 0007 (6 pgs)0	WP 0036 (2 pgs)0
WP 0008 (6 pgs)0	WP 0037 (2 pgs)0
WP 0009 (22 pgs)0	WP 0038 (2 pgs)0
WP 0010 (6 pgs)0	WP 0039 (2 pgs)0
WP 0011 (6 pgs)0	WP 0040 (2 pgs)0
WP 0012 (4 pgs)0	WP 0041 (2 pgs)0
Chp 3 title page0	WP 0042 (2 pgs)0
WP 0013 (2 pgs)0	WP 0043 (2 pgs)0
WP 0014 (6 pgs)0	Chp 8 title page0
Chp 4 title page0	WP 0044 (2 pgs)0
WP 0015 (4 pgs)0	WP 0045 (4 pgs)0
WP 0016 (8 pgs)0	WP 0046 (2 pgs)0
WP 0017 (2 pgs)0	WP 0047 (10 pgs)0
Chp 5 title page0	WP 0048 (2 pgs)0
WP 0018 (6 pgs)0	WP 0049 (2 pgs)0
WP 0019 (4 pgs)0	WP 0050 (4 pgs)0
WP 0020 (2 pgs)0	WP 0051 (6 pgs)0
WP 0021 (4 pgs)0	INDEX 1 – INDEX 60
WP 0022 (4 pgs)0	Back Cover0
WP 0023 (4 pgs)0		

TECHNICAL MANUAL

**OPERATOR'S MANUAL AND UNIT MAINTENANCE MANUAL
INCLUDING REPAIR PARTS AND SPECIAL TOOLS LIST (RPSTL)
FOR**

**FORWARD AREA WATER POINT
SUPPLY SYSTEM (FAWPSS)
MODEL LAB 9095
(NSN 4320-01-359-0369) (EIC ZFW)
MODEL M105
(NSN 4320-01-532-7057)**

REPORTING ERRORS AND RECOMMENDING IMPROVEMENTS

You can help improve this publication. If you find any mistakes or if you know of a way to improve the procedures, please let us know. Submit your DA Form 2028 (Recommended Changes to Publications and Blank Forms), through the Internet, on the Army Electronic Product Support (AEPS) website. The Internet address is <https://aeps.ria.army.mil>. The DA Form 2028 is located under the Public Applications section in the AEPS Public Home Page. Fill out the form and click on SUBMIT. Using this form on the AEPS will enable us to respond quicker to your comments and better manage the DA Form 2028 program. You may also mail, fax or e-mail your letter or DA Form 2028 direct to: AMSTA-LC-LPIT/TECH PUBS, TACOM-RI, 1 Rock Island Arsenal, Rock Island, IL 61299-7630. The E-mail address is ROCK-TACOM-TECH-PUBS@ria.army.mil. The fax number is DSN 793-0726 or Commercial (309) 782-0726.

*TM 10-4320-346-12&P dated 16 March 2007 supersedes TM 10-4320-346-12&P dated 30 April 1993, including all changes.

DISTRIBUTION STATEMENT A: Approved for public release; distribution is unlimited.

TABLE OF CONTENTS

	<u>WP Sequence No.</u>
Warning Summary	Warning a
How to Use This Manual	v
 CHAPTER 1 - GENERAL INFORMATION, EQUIPMANT DESCRIPTION, AND THEORY OF OPERATION	
General Information	WP 0001
Equipment Description and Data	WP 0002
Theory of Operation	WP 0003
 CHAPTER 2 - OPERATOR INSTRUCTIONS	
Description and Use of Operator Controls and Indicators	WP 0004
Operation Under Usual Conditions	WP 0005
Site Requirements and Layouts	WP 0006
Assembly and Preparation for Use – Model LAB 9095	WP 0007
Assembly and Preparation for Use – Model M105	WP 0008
Filling and Movement of Drums	WP 0009
Disassembly for Movement – Model LAB 9095	WP 0010
Disassembly for Movement – Model M105	WP 0011
Operation Under Unusual Conditions	WP 0012
 CHAPTER 3 - OPERATOR TROUBLESHOOTING PROCEDURES	
Operator Troubleshooting Symptom Index	WP 0013
Operator Troubleshooting Procedures	WP 0014
 CHAPTER 4 - OPERATOR MAINTENANCE INSTRUCTIONS/PMCS	
Preventive Maintenance Checks and Services (PMCS) Introduction	WP 0015
Preventive Maintenance Checks and Services (PMCS) and Lubrication Instructions	WP 0016
Maintenance	WP 0017
 CHAPTER 5 - UNIT MAINTENANCE INSTRUCTION/PMCS	
Service Upon Receipt of Material	WP 0018
Preventive Maintenance Checks and Services (PMCS) Introduction	WP 0019
Preventive Maintenance Checks and Services (PMCS) and Lubrication Instructions ...	WP 0020
Hose Assembly Maintenance	WP 0021
Ball Valve Assembly Maintenance	WP 0022
Nozzle Assembly Maintenance	WP 0023
Nozzle Stand Assembly Maintenance	WP 0024

TABLE OF CONTENTS (Contd)

WP Sequence No.

CHAPTER 5 – UNIT MAINTENANCE INSTRUCTION/PMCS (Contd)

Towing and Lifting Yoke Maintenance WP 0025
 Miscellaneous Fittings Maintenance WP 0026
 Tiedown Assemblies Maintenance WP 0027
 General Maintenance WP 0028

CHAPTER 6 – UNIT TROUBLESHOOTING PROCEDURES

Unit Troubleshooting Symptom Index WP 0029
 Unit Troubleshooting Procedures WP 0030

CHAPTER 7 – PARTS INFORMATION

Introduction WP 0031
 GROUP 0100 Hose Assemblies WP 0032
 GROUP 0200 Ball Valve Assembly WP 0033
 GROUP 0300 Nozzle Assembly WP 0034
 GROUP 0400 Nozzle Stand Assembly WP 0035
 GROUP 0500 Towing and Lifting Yoke WP 0036
 GROUP 0600 Miscellaneous Fittings WP 0037
 GROUP 0700 Fabric Drum Assemblies WP 0038
 GROUP 0800 Pump Units WP 0039
 GROUP 0900 Tiedown Assemblies WP 0040
 GROUP 1000 Bulk Materials WP 0041
 National Stock Number (NSN) Index WP 0042
 Part Number Index WP 0043

CHAPTER 8 – SUPPORTING INFORMATION

References WP 0044
 Maintenance Allocation Chart (MAC) Introduction WP 0045
 Maintenance Allocation Chart (MAC) WP 0046
 Components of End Item (COEI) and
 Basic Issue Items (BII) Lists WP 0047
 Additional Authorization List (AAL) WP 0048
 Expendable and Durable Items List WP 0049
 Illustrated List of Manufactured Items WP 0050
 Torque Limits WP 0051
 Index INDEX-1

HOW TO USE THIS MANUAL

ABOUT YOUR MANUAL

Equipment operators shall familiarize themselves with the format and use of this technical manual (TM) prior to operating equipment or performing routine maintenance. Learning how to use this manual will enable personnel to quickly locate information, gain proper knowledge of the equipment, and shorten the time necessary to complete the required procedure.

Features of this TM are:

- a. **Work Package Format**—This TM is organized in Work Package (WP) format. Each WP is an individual, stand-alone unit of information identified by a four-digit sequence number. WPs are positioned within the TM in sequential order (i.e., 0001, 0002, 0003, etc.), and each WP is page numbered consecutively after the sequence number at the bottom of each page (i.e., 0001-1, 0001-2, 0001-3, etc.). A WP may contain as many as thirty pages.
- b. **Text Design** — A Table of Contents (TOC) is located in the front matter section of the TM. WP titles and sequence numbers are listed in the TOC in sequential order. WPs are organized into chapters based on subject, and chapters are listed in the TOC. Chapter title pages are positioned sequentially within the manual, and each chapter title page contains an index of the WPs in that chapter only. In addition to the TOC and chapter title pages, a separate subject index is located in the rear matter section of the TM. The subject index is organized in alphabetical order with WP sequence and page numbers provided.

Each WP contains identification information which includes the following:

1. Maintenance level(s) – This identifies what maintenance level(s) can perform the task.
2. WP title – This identifies the equipment name, title of procedure and where applicable, the title of the subtasks within the WP.
3. Effectivity notice – This is only listed when a WP does not apply to all configurations or models of the equipment, in which case only the model(s) that apply are listed.

Initial setup requirements may be listed after the WP identification information above. The Initial Setup contains a list of all tools, materials/parts, authorized personnel, reference information, equipment conditions that must be performed first, special environmental conditions, and any other specific information required to perform and complete the task.

- c. **Use of Text and Illustrations** — WP text may be presented as general information written in paragraphs, a single task having numbered steps, or two or more subtasks each containing separate information, e.g., removal, cleaning, inspection. Where steps are used, they must be followed in the order which they are numbered. When illustrations are used, they are located after the text to which they apply on facing two-page modules, and are identified in the text by figure and item numbers. Each illustration has a figure number and title beneath it, and may contain item numbers with arrows pointing to each part called out in the corresponding text. Illustration callouts are numbered sequentially, starting at the 11 o'clock position, and continue clockwise around the illustration. Tables and figures are numbered sequentially within each WP. Abbreviations and acronyms are spelled out within the text the first time they appear in the manual only. A list of all abbreviations and acronyms used in this TM is provided in General Information, WP 0001.

HOW TO USE YOUR MANUAL

The format of this manual is designed to make accessing information quick and easy. The following example is intended as a guide and should be reviewed and put to memory before attempting to use this manual. If you have any questions after reviewing the following example, don't hesitate to ask your supervisor.

PROBLEM: You observe while operating the FAWPSS that water continues to flow from one of the dispensing nozzles after the nozzle lever is released.

SOLUTION: You must find information on the nozzles in the manual, review the operating procedures, and if necessary, perform the appropriate troubleshooting tasks to solve the problem.

HOW TO USE THIS MANUAL (Contd)

HOW TO USE YOUR MANUAL (Contd)

1. Refer to the TOC to determine what chapter and WP contains information on operation of the nozzle assembly. If there is not an obvious WP title that indicates information on operation of the nozzle assembly, you may locate the information more quickly by using the subject index. After reviewing the TOC and/or subject index, you determine that Chapter 2, Operation Under Usual Conditions, WP 0004, and Chapter 3, Troubleshooting Procedures, WP 0014, contain the information you desire.
2. Go to WP 0004 and review the operating procedures pertaining to operating the nozzle. Then go to WP 0013 and look through the list of symptom descriptions in the Operator Troubleshooting Index until you identify the fault number that most accurately fits the problem.
3. Go to WP 0014, fault number 5, Nozzle Assembly Leaking, and follow the steps listed. As you perform the troubleshooting procedure you discover the nozzle lever appears to not release all the way resulting in the valve not completely closing. Since disassembly of the nozzle assembly is not authorized at the operator's level, you must notify unit maintenance as instructed.
4. Unit level maintenance will refer to the TOC or subject index for unit level troubleshooting and maintenance procedures. In this example, go to Chapter 6, WP 0029 and WP 0030, and verify the nozzle assembly is at fault as determined at operator's level. Using the TOC or subject index again, find the maintenance task for the nozzle assembly; in this example, go to Chapter 5, WP 0023. Review the initial setup and read through the entire procedure first, then perform the task steps in the order written, making sure you follow all warnings, cautions, and notes. As you clean, disassemble, and inspect the nozzle assembly you discover and remove a small piece of debris lodged in the valve body. The debris is likely to have limited the travel of the valve and is the obvious cause of the problem. You must complete the task, test and verify the nozzle no longer leaks under operation, and then return it to service.

CHAPTER 1

GENERAL INFORMATION, EQUIPMENT DESCRIPTION, AND THEORY OF OPERATION FOR FORWARD AREA WATER POINT SUPPLY SYSTEM (FAWPSS)

General Information	WP 0001
Equipment Description and Data	WP 0002
Theory of Operation	WP 0003

**OPERATOR AND UNIT MAINTENANCE
FORWARD AREA WATER POINT SUPPLY SYSTEM (FAWPSS)
GENERAL INFORMATION**

SCOPE

This Technical Manual (TM) contains operator and unit level instructions for the operation and servicing of the Forward Area Water Point Supply System (FAWPSS). Operating instructions include safety requirements, description of equipment, use of controls, and operation under usual and unusual conditions. Servicing instructions include operator and field level Preventive Maintenance Checks and Services (PMCS), lubrication, maintenance procedures, and troubleshooting as allocated by the Maintenance Allocation Chart (MAC). Replacement of components is performed at unit level. Parts information is provided for all end items except the centrifugal pump and collapsible fabric tank.

- a. **Type of Manual** – Operator’s and Unit Maintenance including Repair Parts and Special Tools List
- b. **Equipment Name and Model Number** – Forward Area Water Point Supply System, Model LAB 9095 and Model M105
- c. **Purpose of Equipment** – FAWPSS Model LAB 9095 and Model M105 are designed to receive, store, and dispense potable drinking water. FAWPSS Model M105 is configured for transport on a Palletized Load System (PLS) Flatrack or Container Roll In/Roll Out Platform (CROP) for the Brigade Combat Team (BCT).

MAINTENANCE FORMS, RECORDS, AND REPORTS

Department of the Army forms and procedures used for equipment maintenance will be those prescribed by (as applicable) Department of Defense Pamphlet (DA PAM) 750-8, The Army Maintenance Management System (TAMMS) Users Manual.

REPORTING EQUIPMENT IMPROVEMENT RECOMMENDATIONS (EIR)

If your FAWPSS needs improvement, let us know. Send us an Equipment Improvement Recommendation (EIR). You, the user, are the only one who can tell us what you don’t like about your equipment. Let us know why you don’t like the design or performance. If you have Internet access, the easiest and fastest way to report problems or suggestions is to go to <https://aeps.ria.army.mil/aepspublic.cfm> (scroll down and choose the “Submit Quality Deficiency Report” bar). The Internet form lets you choose to submit an EIR, a Product Quality Deficiency Report (PQDR), or a Warranty Claim Action (WCA). You may also submit your information using Standard Form (SF) 368, PQDR. You can send your SF 368 via e-mail, regular mail, or facsimile using the addresses/facsimile numbers specified in DA PAM 750-8, TAMMS Users Manual. We will send you a reply.”

HAND RECEIPT

There is not a separate Hand Receipt for the FAWPSS. For a complete list of end-item-related equipment (i.e., COEI, BII, and AAL) that must be accounted for, refer to WP 0047 and WP 0048.

CORROSION PREVENTION AND CONTROL (CPC)

Corrosion Prevention and Control (CPC) of Army materiel is a continuing concern. It is important that any corrosion problem with this item be reported so that the problem can be corrected and improvements can be made to prevent the problem in future items.

Corrosion specifically occurs with metals. It is an electrochemical process that causes the degradation of metals. It is commonly caused by exposure to moisture, acids, bases, or salts. An example is the rusting of iron. Corrosion damage in metals can be seen, depending on the metal, as tarnishing, pitting, fogging, surface residue, and/or cracking.

Plastics, composites, and rubbers can also degrade. Degradation is caused by thermal (heat), oxidation (oxygen), solvation (solvents), or photolytic (light, typically UV) processes. The most common exposures are excessive heat or light. Damage from these processes will appear as cracking, softening, swelling, and/or breaking.

SF 368, PQDR, should be submitted to the address specified in DA PAM 750-8, TAMMS Users Manual.

OZONE DEPLETING SUBSTANCES (ODS)

The use of ODS for new acquisitions has been curtailed by Executive Order 12856, 3 August 1993, other relevant public laws, and Department of Defense (DOD) and Army Policy.

GENERAL INFORMATION (Contd)**DESTRUCTION OF ARMY MATERIEL TO PREVENT ENEMY USE**

Procedures for destruction of army materiel to prevent enemy use can be found in TM 750-244-3, Procedures for Destruction of Equipment to Prevent Enemy Use.

PREPARATION FOR STORAGE OF EQUIPMENT

For preparation for storage or shipment, refer to WP 0028. Additional information can be found in TM 746-10, Marking, Packaging and Shipment of Supplies and Equipment: General Packaging Instructions for Field Use.

LIST OF ABBREVIATIONS/ACRONYMS

Abbreviations and acronyms appearing in this manual are defined in the paragraph from where they first appear, after which only the abbreviation or acronym is used. The following is a quick-reference list of all abbreviations and acronyms and their corresponding word or compound term used in this manual.

AAL – Additional Authorized List	mph – miles per hour
AEPS – Army Electronic Product Support	MQD – Male Quick-disconnect
BII – Basic Issue Items	NATO – North Atlantic Treaty Organization
BCT – Brigade Combat Team	N/A – Not Applicable
CAGE – Commercial and Government Entity Code	NCOIC – Non-Commissioned Officer In Charge
CDI – Cubic Inch Displacement	NSN – National Stock Number
Cm – centimeter	ODS – Ozone Depleting Substances
COEI – Component of End Item and Services	OZ – Ounces
CPC – Corrosion Prevention and Control	PLS – Palletized Load System
CROP – Container Roll In/Roll Out Platform	PMCS – Preventive Maintenance Checks and Services
cu – cubic	PQDR – Product Quality Deficiency Report
DA-PAM – Department of Army Pamphlet	pt – pint
DIA – Diameter	PSI – Pounds Per Square Inch
DOD – Department of Defense	QDR – Quality Deficiency Report
EA – Each	qt – quart
EDRS – Electronic Deficiency Reporting System	rpm – revolutions per minute
EIR – Equipment Improvement Recommendation	RPSTL – Repair Parts and Special Tools List
F – Fahrenheit	TAMMS – The Army Maintenance Management System
FAWPSS – Forward Area Water Point Supply System	TM – Technical Manual
FM – Field Manual	TOC – Table of Contents
ft – foot	UOC – Useable On Code
FWD – Forward	Vdc – Volts Direct Current
FQD – Female Quick-disconnect	WCA – Warranty Claim Action
GAL – Gallon	WP – Work Package
GPM – Gallons per Minute	
GCWR – Gross Combination Weight Rating	
GVW – Gross Vehicle Weight	
GVWR – Gross Vehicle Weight Rating	
hp – horsepower	
IAW – in accordance with	
in. – inch	
kg – kilogram	
Km/h – Kilometers per hour	
kPa – Kilopascals	
lb – pound	
L – Liters	
LPM – Liters Per Minute	
MAC – Maintenance Allocation Chart	
mm – millimeter	

GENERAL INFORMATION (Contd)**NOMENCLATURE CROSS REFERENCE LIST**

The following is a table of official nomenclature used in this manual and the corresponding unofficial nomenclature (common names or jargon terms) used in the field.

Table 1. Nomenclature Cross Reference List.

OFFICIAL TM NOMENCLATURE	UNOFFICIAL NOMENCLATURE
Bow	Shackle
Wye, Quick-disconnect	Y-fitting
Tank, Fabric, Collapsible	Drum, Fabric, Collapsible
Nipple, Quick-disconnect	Male Adapter

SUPPORTING INFORMATION FOR REPAIR PARTS, SPECIAL TOOLS, TMDE, AND SUPPORT EQUIPMENT

Refer to Chapter 8, WP 0044 through WP 0051 for supporting information. Repair parts are listed and illustrated in Chapter 7, Parts Information, WP 0031 through WP 0043 of this manual. There are no special tools allocated for the FAWPSS.

END OF WORK PACKAGE

0001-3/4 blank

**OPERATOR AND UNIT MAINTENANCE
FORWARD AREA WATER POINT SUPPLY SYSTEM (FAWPSS)
EQUIPMENT DESCRIPTION AND DATA**

EQUIPMENT CHARACTERISTICS, CAPABILITIES, AND FEATURES

The FAWPSS is a drinking water distribution system comprised of several individual components that provide a means to receive, store, and dispense potable drinking water. Essentially, water is dispensed by pumping it from one or more storage containers through hoses to separate nozzles called dispensing points. These dispensing points are then used by the troops to fill individual containers for consumption. The FAWPSS is configured to be transported, assembled, and filled in the field (Model LAB 9095) or assembled, filled, and transported to the field on a PLS Flatrack or CROP (Model M105) where a safe supply of drinking water is essential for the troops. Its use is limited to the distribution of potable water only.

There are six major components of the FAWPSS: the collapsible fabric drum, the coupler valve, the pump unit, the hose assembly, the ball valve, and the distribution nozzle. Quantities of these components and their set up vary by model. Refer to figures 1 and 2 for typical set ups. To assemble and operate the FAWPSS, one or more drums are positioned on the ground or on a Flatrack and filled with water. Hoses and valves having quick-disconnect couplings are connected from the drums to the pump unit to separate nozzles. By opening the valves on the drums and hoses, and operating the pump unit, water can be dispensed from any nozzle by squeezing the nozzle lever. To prevent contamination and facilitate their use, nozzles are hooked to a tripod type stand.

Each collapsible fabric drum will hold 500 gallons (GAL) (1893 liters (L)) of water at a weight of approximately 4,353 pounds (lb) (1975 kilograms (kg)). Once filled, drums can be maneuvered on the ground or lifted by use of a towing and lifting yoke and a suitable vehicle, lifting device, or helicopter. The BCT configuration (Model M105) makes the FAWPSS more portable and mobile by eliminating the need to lift or empty drums individually in order to transport them. This is accomplished by securing three drums to a PLS Flatrack or CROP for movement.

The centrifugal pump unit is capable of delivering 125 gallons per minute (GPM) and a 50 foot (ft) (15.3 meter (m)) head. It is powered by a 5.5 horsepower (hp), one cylinder, pull-start, diesel engine. The engine and centrifugal pump are mounted together on a steel frame base for ease of movement, and to prevent damage during transport and operation.

The FAWPSS is fielded as one complete system in one Tricon container. Inside the Tricon container are two wooden crates held in place by two cargo straps. All FAWPSS equipment is packed in the two wooden crates.

EQUIPMENT DESCRIPTION AND DATA (Contd)**EQUIPMENT CHARACTERISTICS, CAPABILITIES, AND FEATURES (Contd)**

The FAWPSS can be operated in a wide range of climate conditions. However, special requirements for storing water filled drums in extreme heat (135° F (57.5° C)) or extreme cold (-50° F (-45° C)) are necessary. For example, in warm climates the drums are kept out of direct sunlight and a chiller may be connected for cooling the water. In temperatures below freezing, water must be drained from the pump immediately after use, and drums containing water must be kept in a heated space.

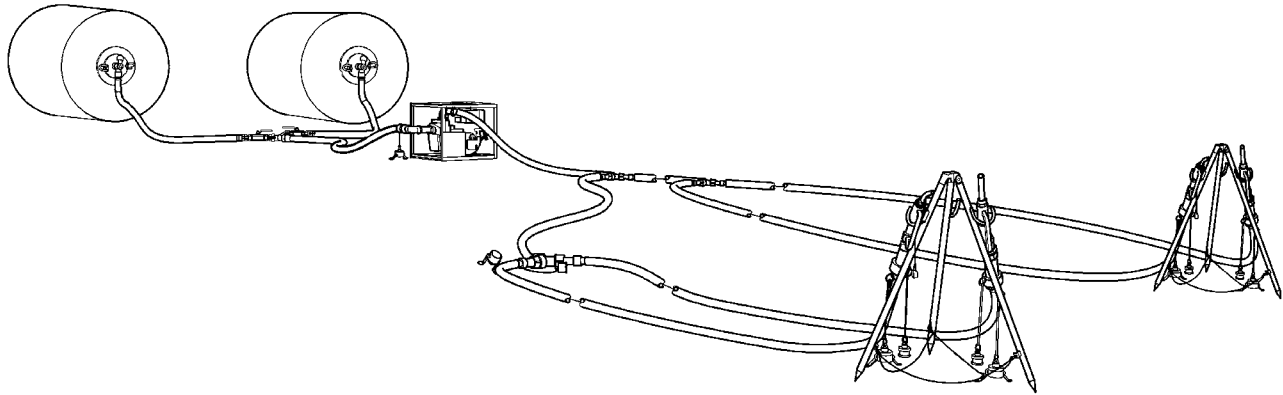

Figure 1. Typical FAWPSS Standard Configuration (Model LAB 9095).

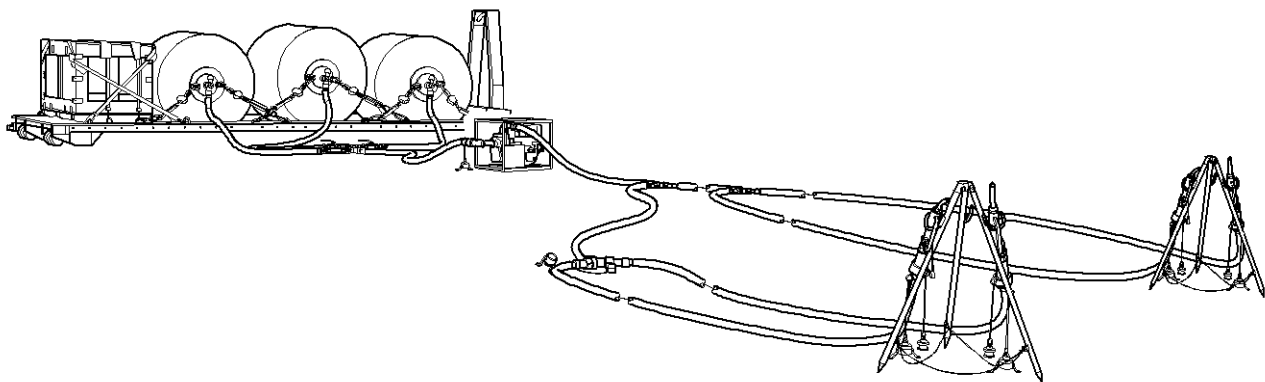

Figure 2. Typical FAWPSS BCT Configuration (Model M105).

EQUIPMENT DESCRIPTION AND DATA (Contd)

LOCATION AND DESCRIPTION OF MAJOR COMPONENTS

1. **COLLAPSIBLE FABRIC DRUM** — The drum or tank is a reusable, collapsible container that stores up to 500 GAL (1,893 L) of potable water. It is positioned for use on the ground (Model LAB 9095) or on a PLS Flatrack or CROP (Model M105).
2. **TOWING AND LIFTING YOKE** — (Included with FAWPSS Model LAB 9095 only) This yoke is a collapsible frame that attaches to the swivel plate on the ends of the drum, and is used for ground towing and external helicopter air lifting of filled drums.
3. **COUPLER VALVE** — Each drum is furnished with two, 2 inch (in.) diameter (DIA) Female Quick-disconnect (FQD) x FQD coupler valves used to control the intake or supply of water to and from the drum. The coupler valve connects to the adapter assembly, located at each end of the drum, and receives the suction hose.
4. **2-IN. DIA X 10 FT SUCTION HOSE ASSEMBLY** — This hose is used between the coupler valve and ball valve, the quick-disconnect wye and pump suction port, and the pump discharge port and quick-disconnect wye on the discharge side. Each suction hose assembly measures 10 ft (3.1 m) in length, and has 2 in. DIA male and female quick-disconnect coupling halves that are cam-locking. In addition, the male and female coupling halves are equipped with a protective cap and plug to prevent contamination when not in use. When removed, the cap and plug are individually retained by a small chain to prevent loss.

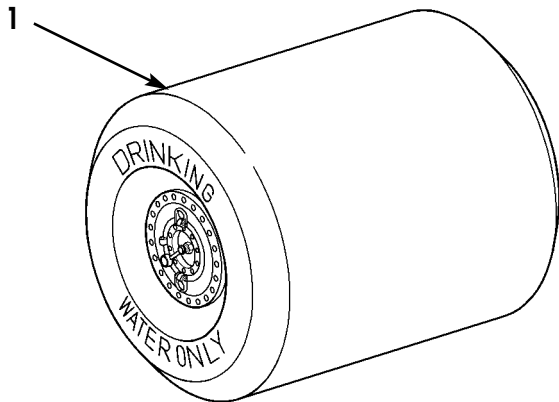

Figure 3. Drum Assembly.

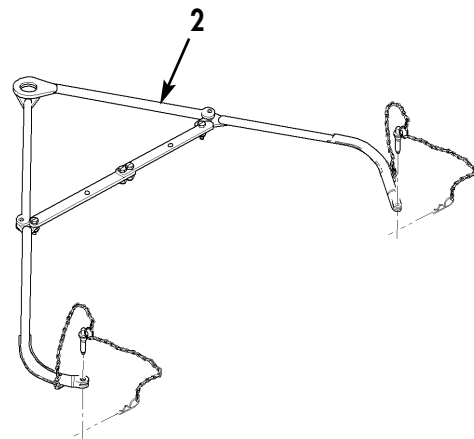

Figure 4. Yoke Assembly.

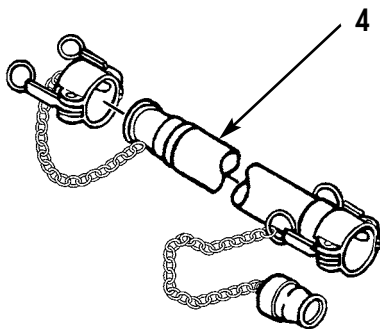

Figure 5. Suction Hose Assembly.

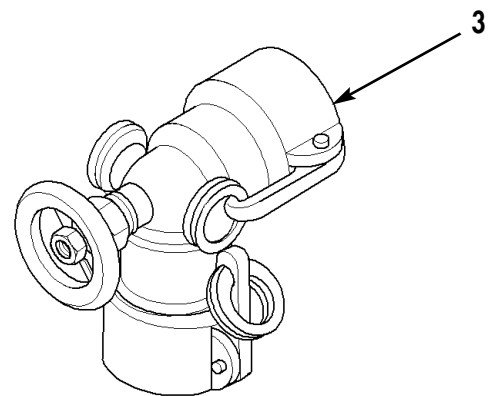

Figure 6. Coupler Valve.

EQUIPMENT DESCRIPTION AND DATA (Contd)**LOCATION AND DESCRIPTION OF MAJOR COMPONENTS (Contd)**

5. **BALL VALVE** — The ball valve is positioned between the suction hose and the quick-disconnect wye leading to the suction side of the centrifugal pump. The ball valve is a quick-acting lever operated valve used to control the amount of water entering the pump. A ball valve is utilized for each drum to allow flexibility in choosing which drum(s) will be used for distribution of water.
6. **QUICK-DISCONNECT WYE** — This Y-fitting is used to link two or more drums to a central suction hose leading to the pump unit. It is also used to link discharge hoses leading to two or more water distribution nozzles. It has one female and two male cam-locking, 2 in. DIA coupling ends.
7. **CENTRIFUGAL PUMP UNIT** — The pump unit is positioned and operated on the ground between the drums and nozzles for the purpose of delivering water under pressure to the distribution points. The suction port is located on the side of the pump housing, and the discharge port is located on the top. Both ports utilize 2 in. (51 mm) DIA pipe fittings and cam-locking quick-disconnect coupling ends. The pump is self-priming and driven by a one cylinder diesel engine.
8. **MILITARY FUEL CAN** — This fuel can is provided to refuel the 1 GAL (3.8 L) capacity fuel tank for the centrifugal pump unit's diesel engine. The fuel can holds 5 GAL (19 L) and a removable, flexible spout is provided.
9. **2 IN. DIA X 25 FT DISCHARGE HOSE ASSEMBLY** — This hose is used between the quick-disconnect wye on the discharge side of the pump and the quick-disconnect wyes leading to the nozzles. Each discharge hose assembly measures 25 ft (7.6 m) in length, and has 2 in. DIA male and female quick-disconnect coupling halves that are cam-locking. In addition, the male and female coupling halves are equipped with a protective cap and plug to prevent contamination when not in use. When removed, the cap and plug are individually retained by a small chain to prevent loss.
10. **QUICK-DISCONNECT REDUCER** — The reducer is connected between the 2 in. DIA Wye quick-disconnect and the 1.5 in. DIA discharge hose assembly leading to the water distribution nozzle. It has a cam-locking 2 in. DIA FQD coupling end and a 1.5 in. MQD coupling end.

EQUIPMENT DESCRIPTION AND DATA (Contd)

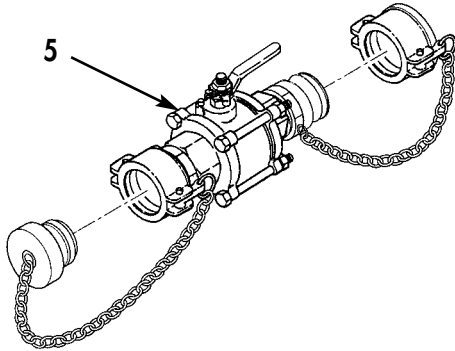

Figure 7. Ball Valve.

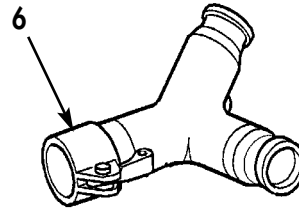

Figure 8. Quick Disconnect Wye.

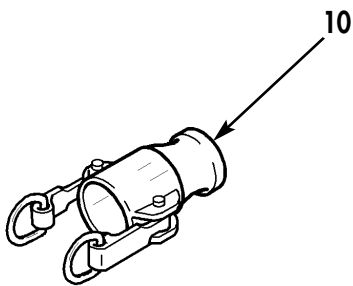

Figure 9. Reducer.

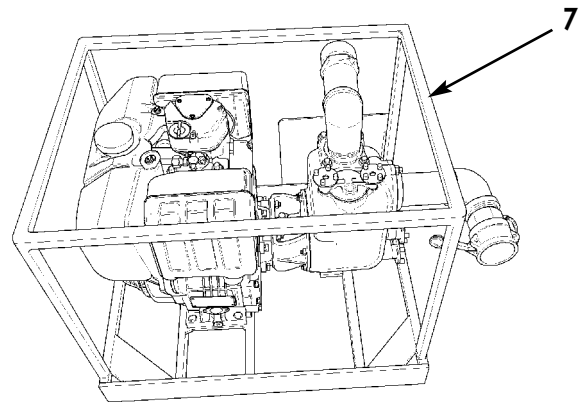

Figure 10. Centrifugal Pump Unit .

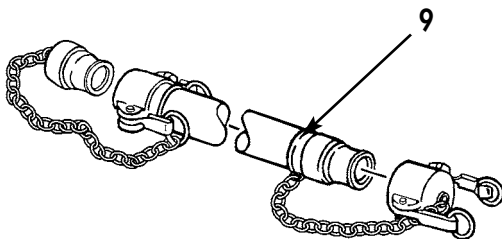

Figure 11. Discharge Hose Assembly.

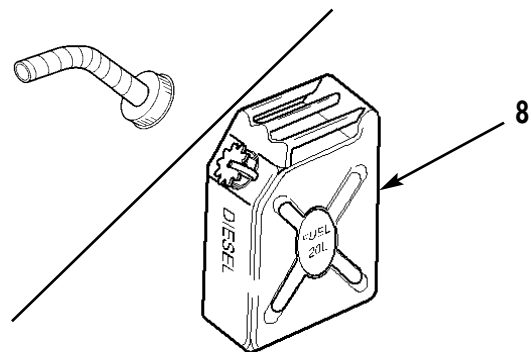

Figure 12. Fuel Can and Spout.

EQUIPMENT DESCRIPTION AND DATA (Contd)**LOCATION AND DESCRIPTION OF MAJOR COMPONENTS (Contd)**

11. **1.5 IN. X 25 FT DIA DISCHARGE HOSE ASSEMBLY** — This hose is used between the reducer and the nozzle assembly. Each suction hose assembly measures 25 ft (37.6 m) in length, and has 1.5 in. DIA male and female quick-disconnect coupling halves that are cam-locking. In addition, the male and female coupling halves are equipped with a protective cap and plug to prevent contamination when not in use. When removed, the cap and plug are individually retained by a small chain to prevent loss.
12. **WATER DISTRIBUTION NOZZLE** — The nozzle assembly is connected to the 1.5 in. DIA discharge hose assembly, and is the distribution point for dispensing water. The inlet side of the nozzle has a 1 in. DIA swivel fitting and a 1.5 in. DIA FQD, cam-locking coupling half. The outlet side or spout of the nozzle assembly is furnished with a dust cap held by a spring tensioned retaining chain.
13. **DISTRIBUTION STAND ASSEMBLY** — The stand assembly is positioned on the ground at the desired distribution point and supports up to three water distribution nozzles. The stand assembly hinges open to become a tripod, and nozzles are supported on the stand by a hook shaped bracket mounted on each of the three legs.
14. **TIEDOWN KIT (Included with FAWPSS Model M105 only)** — This kit is used to secure three drums and one equipment crate to a PLS Flatrack or CROP. The kit includes ten ratcheting tiedown straps, sixteen nylon protective sleeves, and twelve chain and tensioner tiedown assemblies.
15. **FABRIC DRUM REPAIR KIT** — This kit is supplied to temporarily repair leaks in the drum resulting from punctures.
16. **FAWPSS TECHNICAL MANUAL** — The FAWPSS TM is the only Basic Issue Item (BII) required for operation on the FAWPSS.

EQUIPMENT DESCRIPTION AND DATA (Contd)

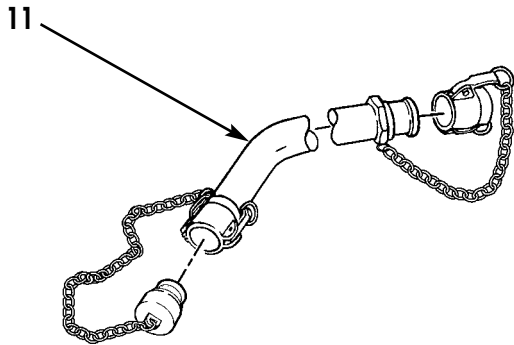

Figure 13. Discharge Hose, 1.5 Inch.

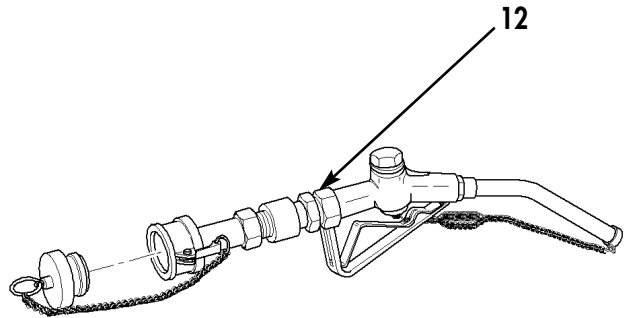

Figure 14. Nozzle Assembly.

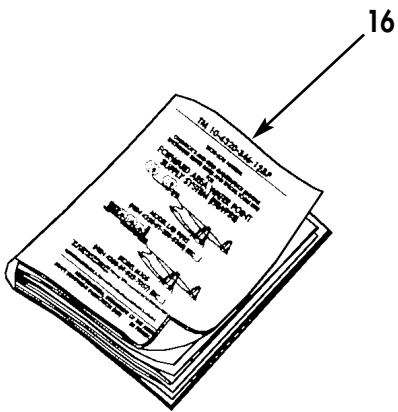

Figure 15. Technical Manual.

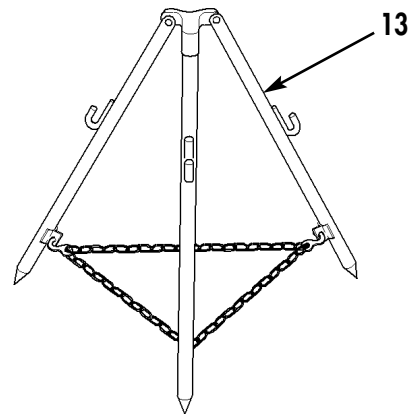

Figure 16. Stand Assembly.

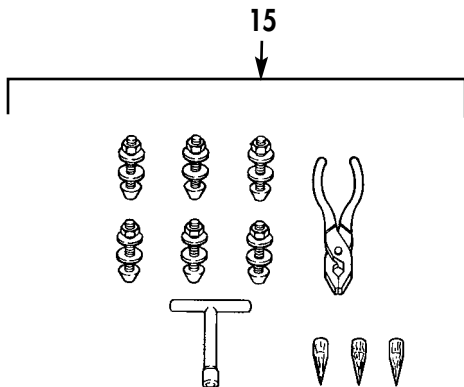

Figure 17. Fabric Drum Repair Kit.

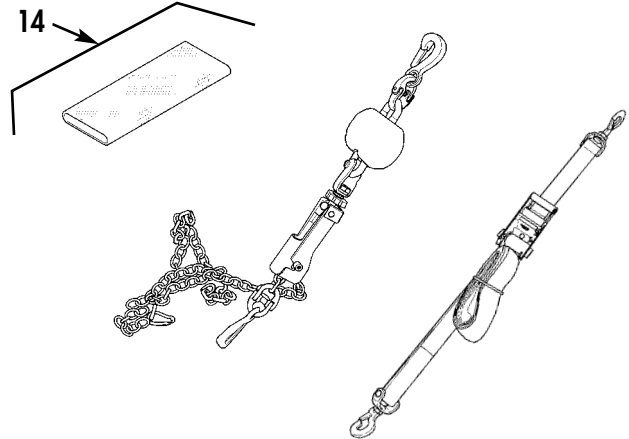

Figure 18. Tiedown Kit.

EQUIPMENT DESCRIPTION AND DATA (Contd)**DIFFERENCES BETWEEN MODELS**

Differences between the FAWPSS Model LAB 9095 and Model M105 are limited to component quantities, layout, and transportability, with only minor differences in part configuration; these differences do not affect basic operating and maintenance procedures. There are no interchangeability differences between the two models; both utilize the same components. The primary difference between the two models is in how they are transported. Model M105 is designed to utilize a PLS Flatrack or CROP to support filled drums for increased mobility and decreased assembly time prior to operation. This model eliminates the need to truck water to the field to fill drums by enabling the drums to be easily moved to and from the water source or to a new position in the field. In addition, Model M105 is equipped to support the BCT's potable water needs for 30 day durations. To help identify quantity and configuration differences between models for major FAWPSS components, refer to table 1 and figures 1 and 2 in this work package, and the Useable On-Codes (UOC) listed in the Component of End item (COEI) and Repair Parts and Special Tools List (RPSTL) provided in this TM.

Table 1. Differences Between Models.

MAJOR COMPONENTS	MODEL LAB 9095 QUANTITY	MODEL M105 QUANTITY
Collapsible Fabric Drum	6	3
Towing and Lifting Yoke	1	N/A
Coupler Valve	12	6
Suction Hose Assembly	3	4
Ball Valve	2	3
Adapter	1	1
Quick-Disconnect Wye	4	5
Centrifugal Pump Unit	1	1
Military Fuel Can	2	2
Spout, Can, Flexible	1	1
2 in. DIA x 10 ft Discharge Hose Assembly	1	1
2 in. DIA x 25 ft Discharge Hose Assembly	2	2
Quick-disconnect Reducer	4	4
1.5 in. DIA x 25 ft Discharge Hose Assembly	4	4
Water Discharge Nozzle	4	4
Distribution Stand	2	2
Tiedown Kit (Drums)	N/A	1
Fabric Drum Repair Kit	6	3
TRICON Shipping and Storage Container	1	1

EQUIPMENT DESCRIPTION AND DATA (Contd)

EQUIPMENT DATA

NOTE

GTA drum (NSN 5430-01-527-4517) or Amfuel drum (NSN 5430-01-507-2574) may be used with either FAWPSS Model LAB 9095 or Model M105.

Table 2. Collapsible Fabric Drum Equipment Data (NSN 5430-01-527-4514).

Manufacturer	GTA Containers, Inc.
Model Number	GTA/WD500-S01
Capacity	.500 gallons (1892.5 liters)
Working Pressure	4.0 to 5.0 psi (0.2812 to 0.3515 kg. cm ²)
Maximum Proof Pressure	.30 psi (2.109 kg. cm ²)
Maximum Towing Speed	.10 mph (16 kilometers per hour)
Overall dimensions and weight (filled)	
Length, maximum	.58 in. (1.47 m)
Diameter, maximum	.55 in. (1.397 m)
Weight	.4344 lbs. (1974.5 kg)
Cubage	.67 cu. ft. (1.89 m ³)
Vertical Drop Capability (filled)	.12.5 ft. (3.81 m)
Weight (empty)	
Crated, including tie-down assembly	.420 lbs. (190.9 kg)
Uncrated, drum only	.220 lbs. (100 kg)
Dimensions (crated)	
Length	.81.25 in. (2.05 m)
Width	.48 in. (1.22 m)
Height	.16 in. (0.41 m)
Cubage	.36.11 cu. ft. (1.02 m ³)
Repair Kit	
Length	.10.0 in. (0.25 m)
Width	.7.0 in. (0.18 m)
Weight	.1.5 lb. (0.68 kg)

Table 3. Collapsible Fabric Drum Equipment Data (NSN 5430-01-507-2574).

Manufacturer	American Fuel Cell and Coated Fabrics Company (Amfuel®)
Model number	M43669-02
Capacity	.500 gallons (1895 liters)
Working pressure	4.0 to 5.0 psi (0.2812 to 0.3515 kg/cm ²)
Maximum proof pressure	.30 psi (2.109 kg/cm ²)
Maximum towing speed	.10 mph (16 kilometers per hour)
Overall dimensions and weight (filled)	
Length, maximum	.58 in. (1.47 m)
Diameter, maximum	.55 in. (1.40 m)
Weight	.4432 lb. (2010 kg)
Cubage	.67 cu. ft. (1.89 m ³)
Vertical drop capability (filled/horizontally positioned)	.5 ft. (1.52 m)
Weight (empty)	
Crated	.315.0 lb. (143 kg) max
Uncrated	.230.0 lb. (104 kg) max
Dimensions (crated)	
Length	.80.5 in. (2.04 m)
Width	.41.5 in. (1.05 m)
Height	.18.5 in. (0.47 m)
Cubage	.35.8 cu. ft. (1.01 m ³)
Repair Kit	
Length	.10.0 in. (25 cm)
Width	.7.0 in. (18 cm)
Wdight	.1.5 lb. (0.68 kg)

EQUIPMENT DESCRIPTION AND DATA (Contd)

EQUIPMENT DATA (Contd)

Table 4. Centrifugal Pump Unit Equipment Data.

Engine	Length	.22 in. (55.9 cm)
	Width	.46 in. (117 cm)
	Height	.28 in. (71.1 cm)
	Weight	.146 lb (66.2 kg)
	Fuel	JP8
	Horsepower	.5.5 hp
	Idle speed	.1,000 to 1,250 rpm
	Full speed setting (no-load condition)	.3,800 rpm
Pump	Suction and discharge ports diameter	.2 in. (51 mm) dia

Table 5. Capacities.

	Collapsible fabric tank	.500 GAL (1,893 l)
Engine	Crankcase oil (including filter)	.1.3 qt (1.2 l)
	Fuel tank	.1.1 GAL (4.3 l)
Pump	Maximum volume	.125 GPM (473 LPM)
	Maximum head	.50 ft (15.3 m)

Table 6. Shipping Dimensions and Weights.

Drum crate	Length	.86 in. (218 cm)
	Width	.69 in. (175 cm)
	Height	.41 in. (104 cm)
	Cubage	.142 cu ft (4.0 cu m)
	Shipping weight	.1,090 lb (494.4 kg)
	Center of gravity	
	Width	.30.1 (76.5 cm)
	Length	.4.66 ft (1.4 m)
Component crate	Length	.69 in. (218 cm)
	Width	.45 in. (114 cm)
	Height	.39 in. (99 cm)
	Cubage	.73 cu ft (2.0 cu m)
	Shipping weight	.930 lb (422 kg)
	Center of gravity	
	Width	.20.2 (51.2 cm)
	Length	.4.66 ft (1.4 m)
	Total Weight of System	.2,020 lb (916 kg)

EQUIPMENT DESCRIPTION AND DATA (Contd)

EQUIPMENT DATA (Contd)

Table 7. Tricon Container Dimensions and Weights.

External	
Length8 ft (244 cm)
Width6 ft 5-1/2 in. (197 cm)
Height	8 ft (244 cm)
Internal	
Length7 ft 6-1/2 in. (230 cm)
Width6 ft 2-1/16 in. (188 cm)
Height7 ft 5-13/16 in. (228 cm)
Door Opening Width6 ft 1-3/4 in. (187 cm)
Door Opening Height7 ft 1-13/16 in. (216 cm)
Max. Gross Weight14,900 lb (6759 kg)
Tare Weight (without shelves and brackets)2600 lb (1180 kg)
Tare Weight (with shelves and brackets)3200 lb (1452 kg)
Payload Weight12,300 lb (4479 kg)
Internal Volume346.2 ft ³ (9.80 m ³)

LOCATION AND DESCRIPTION OF DATA PLATES

Since the FAWPSS is basically a configuration made up of a number of separate end items assembled for a specific purpose, the system itself does not have a data plate. However, the system will be identified on the wooden shipping crates by National Stock Number (NSN). Refer to the appropriate TM for identification of data plates on the collapsible fabric drum and centrifugal pump unit. Refer to References, WP 0044.

**OPERATOR AND UNIT MAINTENANCE
FORWARD AREA WATER POINT SUPPLY SYSTEM (FAWPSS)
THEORY OF OPERATION**

GENERAL

This work package describes how components of the FAWPSS work, and is provided to give the operator and maintenance technician a basic knowledge of the equipment prior to its use. A description of functional components is provided below.

FUNCTION OF DRUM

The drum is a fabric covered rubberized type bladder designed to hold up to 500 GAL (1893 L) of potable water only. Its design allows it to be light weight and collapsible when empty, and strong enough, when full, to be rolled on the ground or lifted and suspended from either end.

The drum's body is essentially a large rubber bladder with a round hole at each end sealed by a large bulkhead. The bulkhead consists of a closure plate clamped in the drum's opening by a ring. To control the shape of the drum when filled and prevent the plates from pushing out due to water pressure, the plates are held between each other by three cables from inside the drum. The cables also prevent the plates from being pulled out by the forces exerted on the drum when it is either rolled or lifted.

The drum can be filled with water at either end through a coupler valve connected to an adapter assembly, located at the center of each plate. Each adapter assembly contains a check valve that remains closed to prevent water from flowing out of the drum. To open the check valve, a coupler valve must be connected to the adapter assembly and the handwheel on the coupler valve turned clockwise.

Each end of the drum contains a swivel plate mounted to the face of the closure plate. The swivel plate is free to rotate 360 degrees in either direction, and contains two shackles designed to support the weight of a filled drum. The two shackles at each end of the drum are used as tiedown or lifting points, and a third leg on the swivel plate receives the towing and lifting yoke.

Should the drum's body become damaged and develop a leak, small puncture holes 3/8 in. (9.5 mm) DIA or less can be temporarily plugged with a wood peg or bulkhead type plug assembly. A permanent repair to the drum body can be made to holes or cuts up to 5 in. (127 mm) in length by vulcanizing a rubber patch to the damaged area.

FUNCTION OF PUMP UNIT

The pump is directly connected to a single cylinder engine, and both are horizontally shock-mounted to a protective frame. The pump unit is designed to move water from one or more drums through hoses to a designated distribution point.

This is accomplished by turning an impeller inside a sealed casing having a suction port at the center and a discharge port at the top. The ports are fitted with quick-disconnect cam-locking fittings to receive 2 in. (51 mm) hoses equipped with the same style fittings.

The suction port has a check-valve to prevent water in the casing from siphoning out when the pump is stopped. The impeller shaft contains a mechanical dynamic type seal that rotates with the shaft assembly and keeps pumped water from leaking. The impeller turns in an orifice within the casing having a removable wear plate. The correct distance between the top of the impeller blades and the surface of the wear plate is achieved by placing shims between the seal support ring and the impeller.

The centrifugal force generated when the impeller is turned creates a vacuum or suction that enables the pump to be self-priming. However, the pump must be primed the first time it is used. The rotational speed of the engine and impeller determine the flow rate and amount of pressure the pump will generate. The throttle control on the side of the engine can be varied to gain proper pump performance; however, running the engine past the maximum rated speed (3,800 rpm) can result in damage to the engine.

THEORY OF OPERATION (Contd)**ASSEMBLY AND FUNCTION OF FORWARD AREA WATER POINT SUPPLY SYSTEM (FAWPSS)**

To assemble and operate the FAWPSS, one or more drums are positioned on the ground or on a PLS Flatrack or CROP and filled with water. A 10 ft. (3 m) long hose is connected to a coupler valve on each drum, and a ball valve is connected to the opposite end of each hose. If two or more tanks are used, the ball valves are joined by a Y-fitting. A single 10 ft. (3 m) long hose is then connected from the Y-fitting to the suction port of the pump unit. Another 10 ft (3 m) long hose is then connected to the discharge port of the pump unit, and depending on the number of supply points needed, additional Y-fittings and 25 ft (7.6 m) long hoses are connected to this hose. Reducers are used to connect smaller diameter 25 ft (7.6 m) long hoses to the larger diameter Y-fittings. A nozzle is connected to the end of each smaller diameter 25 ft (7.6 m) hose, and supported on a tripod type stand.

To dispense water, the coupler valve on each drum is opened first. Each ball valve is then opened for each drum depending on demand; water may be drawn from two or more drums at the same time or the ball valves may be set to draw water from only one drum at a time. This allows for changing or refilling or repair of drums while the system is in use. To send water to the desired distribution point, the pump unit engine is started and set to high idle. The nozzle is unhooked from the stand, and its dust cap is removed. By placing the nozzle spout in a suitable container and squeezing the nozzle lever, water is dispensed under pressure.

END OF WORK PACKAGE

CHAPTER 2

OPERATOR INSTRUCTIONS FOR FORWARD AREA WATER POINT SUPPLY SYSTEM (FAWPSS)

Description and Use of Operator Controls and Indicators	WP 0004
Operation under Usual Conditions	WP 0005
Site Requirements and Layouts	WP 0006
Assembly of FAWPSS – Model LAB 9095	WP 0007
Assembly of FAWPSS – Model M150	WP 0008
Filling and Movement of Drums	WP 0009
Disassembly for Movement – WP 0010 Model LAB 9095	WP 0010
Disassembly for Movement – Model M105	WP 0011
Operation Under Unusual Conditions	WP 0012

OPERATOR INSTRUCTIONS
FORWARD AREA WATER POINT SUPPLY SYSTEM (FAWPSS)
DESCRIPTION AND USE OF OPERATOR CONTROLS AND INDICATORS

INTRODUCTION

This work package contains a description and illustration for each control and indicator of the FAWPSS. It is important to learn the name, location, and function of all controls and indicators before attempting to operate or perform unit maintenance on the equipment.

1. **TIEDOWN CHAIN TENSIONER** — The chain tensioner is part of the tiedown chain assembly which consists of a length of chain having a snaphook at one end and a tensioner connected to a swivel and snaphook at the opposite end. To tighten the tiedown assembly, hinge the lever out on the tensioner, gather the chain through center of tensioner until tight, place one chain link in slot on tensioner, and hinge the lever fully down. If the tiedown assembly is too loose, gather one additional chain link; if the chain is so tight that the lever cannot be fully closed, gather one less chain link. Turn the handwheel to adjust tension.

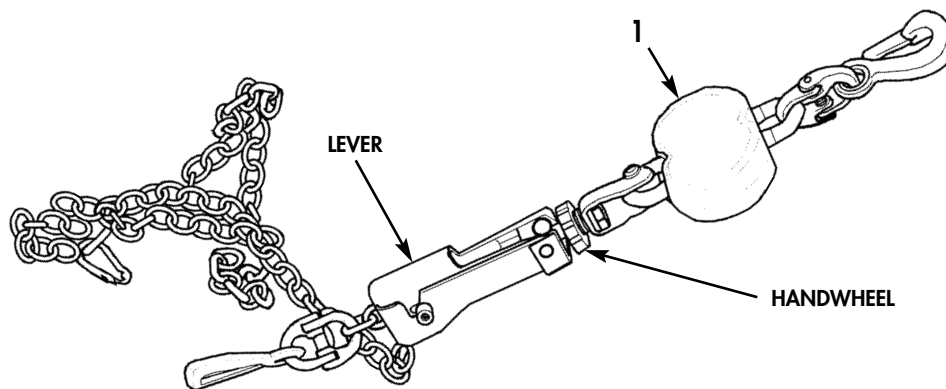

Figure 1. Tiedown Chain.

2. **TIEDOWN STRAP RATCHET** — To operate the ratchet, squeeze the lever on the ratchet handle with one hand and the lever engaging the ratchet wheel with the other, then pull the ratchet handle back approximately 180 degrees until the ratchet wheel is free to turn. Pull the loose end of the strap through the slot in the ratchet wheel until tight, and then rotate the ratchet handle in the opposite direction until the ratchet wheel is engaged. Pull the ratchet handle back and forth to tighten the tiedown strap to the desired tension.

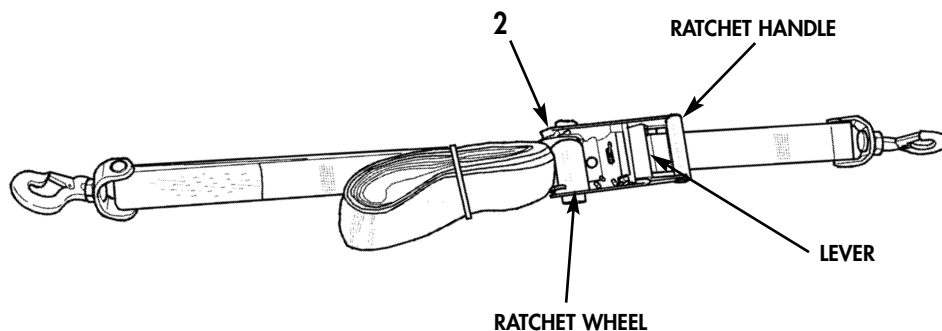

Figure 2. Tiedown Strap.

DESCRIPTION AND USE OF OPERATOR CONTROLS AND INDICATORS (Contd)

3. **DRUM BOWS** — There are two bows (shackles) located on the swivel plate at each end of the drum. The bows are used to receive any type of lifting shackle or snaphook such those provided in the tiedown kit for the drum. The swivel plate may be rotated 360 degrees in either direction to position the bows where necessary.
4. **DRUM ADAPTER ASSEMBLY DUST CAP** — This dust cap is a single plastic piece that slides over the outside diameter of the drum's adapter assembly. To remove, carefully slide the cap off the adapter. Once removed, the cap is retained by a ring that's part of the dust cap.
5. **COUPLER VALVE HANDWHEEL** — The handwheel, located on the coupler valve, is used to open and close the check valve on the drum's adapter assembly. Turning the handwheel to the right (clockwise) opens the valve, and turning the handwheel to the left (counterclockwise) closes the valve.

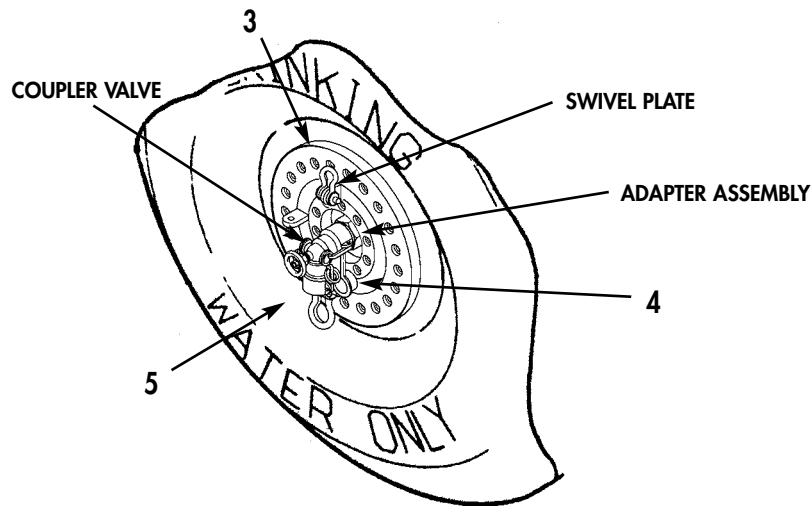

Figure 3. Drum and Coupler Valve.

6. **TOWING AND LIFTING YOKE QUICK-RELEASE PINS** — The quick-release pin, located at the end of each connecting leg, is used to connect the clevis ends of the yoke's connecting legs to the legs on the drum swivel plates. Remove or install the quick-release pin by depressing the button on the end of the pin to release it. The safety pin must be inserted through the hole in the quick-release pin prior to towing or lifting.

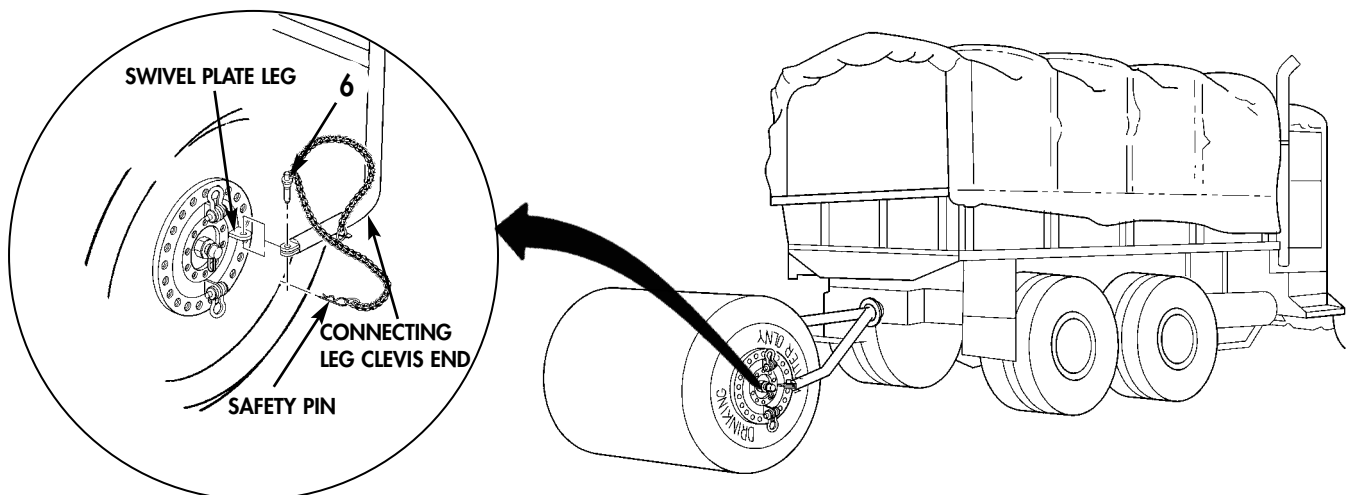

Figure 4. Connecting Yoke and Towing Drum.

DESCRIPTION AND USE OF OPERATOR CONTROLS AND INDICATORS (Contd)

7. **QUICK-DISCONNECT COUPLING CAM ARMS** — All female quick-disconnect couplings on FAWPSS valves, hoses, and fittings are cam locking. To make a connection, first check for presence of gasket inside FQD coupling. The gasket is necessary to prevent leaking. Remove quick-disconnect cap and plug, if installed. Position both cam arms at 90 degree angles to FQD coupling, insert MQD coupling until seated, then swing both cam arms down until tight.

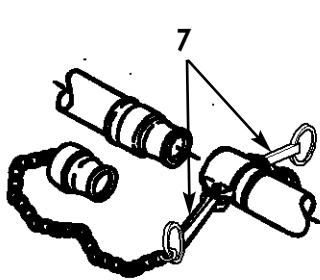

Figure 5. Cam Arms Unlocked.

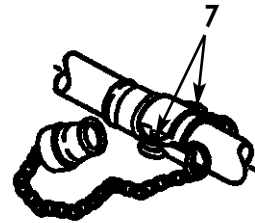

Figure 6. Cam Arms Locked.

8. **QUICK-DISCONNECT PLUG AND CAP** — To prevent contamination, all FAWPSS valves, hoses, and pump quick-disconnect fittings should be capped or plugged when not in use. A gasket must be present for proper sealing. To remove cap or plug, swing both cam levers out at right angles to coupling, and remove cap or plug from coupling. To install, position both cam arms at 90 degree angles, insert plug or position cap on coupling until seated, then swing both cam arms down until tight.

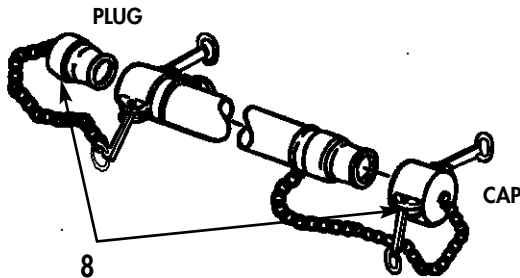

Figure 7. Plug and Cap Removed.

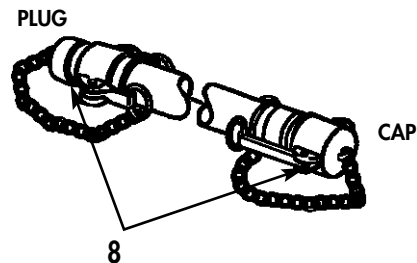

Figure 8. Plug and Cap Installed.

9. **QUICK-DISCONNECT REDUCER** — The reducer is used to connect a 2 in. (51 mm) DIA coupling to a 1.5 in. (38 mm) diameter coupling. The quick-disconnect cam arms on the female coupling end are positioned at 90 degree angles prior to connecting. The cam-locking end of the reducer must contain a gasket for proper sealing. When connecting to the reducer, once the coupling is seated, swing both cam arms down until tight.

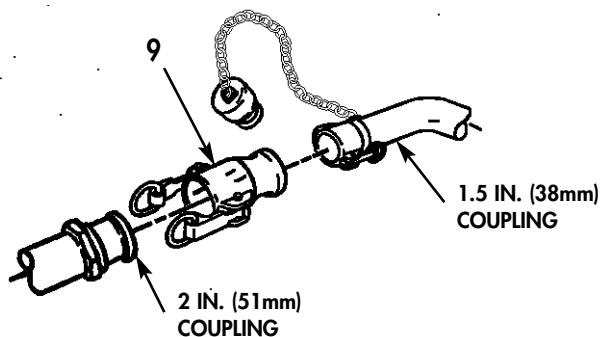

Figure 9. Reducer Installation.

DESCRIPTION AND USE OF OPERATOR CONTROLS AND INDICATORS (Contd)

10. **QUICK-DISCONNECT NIPPLE** — The nipple is an adapter used to connect two female quick-disconnect couplings. First, check for presence of a gasket inside both FQD couplings. The gaskets are necessary to prevent leaking. Remove two quick-disconnect caps from the nipple, if installed. Position cam arms on each FQD coupling at 90 degree angles, insert nipple until seated, and then swing both cam arms down until tight.

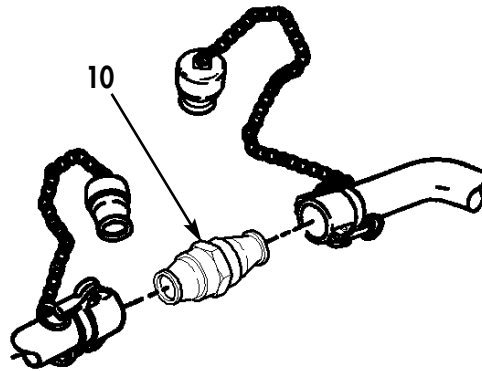

Figure 10. Nipple Installation.

11. **WYE QUICK-DISCONNECT COUPLING** — The Y-coupling is used to connect two FQD couplings to a single MQD coupling. First, check for the presence of a gasket inside the Y-coupling's FQD, and inside the two FQD couplings to be connected to the Y coupling's MQD ends. The gaskets are necessary to prevent leaking. Remove two quick-disconnect caps and one plug from the Y-coupling, if installed. Position cam arms on each FQD end at 90 degree angles, insert coupling ends until seated, and then swing both cam arms down on each FQD coupling until tight.

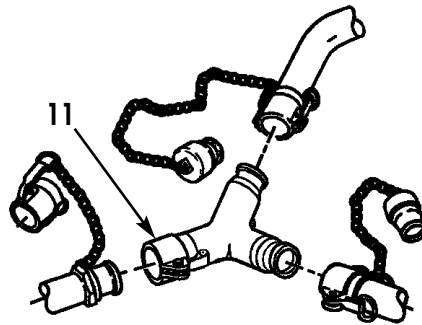

Figure 11. Y-Fitting Installation.

12. **BALL VALVE LEVER** — The ball valve is operated by a lever on the side of the valve body. The ball valve is opened by turning the lever so that its position is in line with the valve body. To close the ball valve, turn the lever so it points away from the valve body at a right angle.

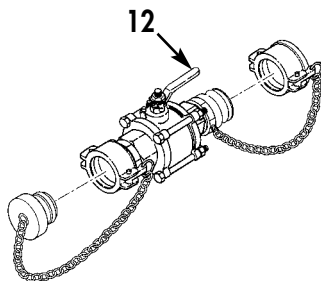

Figure 12. Open Position.

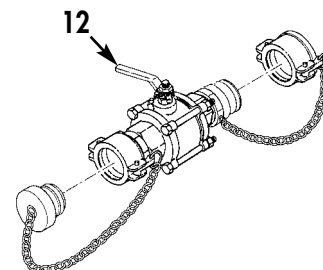

Figure 13. Closed Position.

DESCRIPTION AND USE OF OPERATOR CONTROLS AND INDICATORS (Contd)

13. **ENGINE STOP/START LEVER** — The start/stop lever is located on the side of the cylinder block below the oil dipstick and to the right of the throttle control. Turn the start/stop lever to the right to start the engine and to the left to stop the engine.
14. **ENGINE THROTTLE CONTROL** — The throttle control is located on the side of the cylinder block to the left of the start/stop lever. The engine is set to idle between 1,000 to 1,250 RPM. Turn the throttle control to the left (counterclockwise) toward the MAX mark to increase engine RPM.

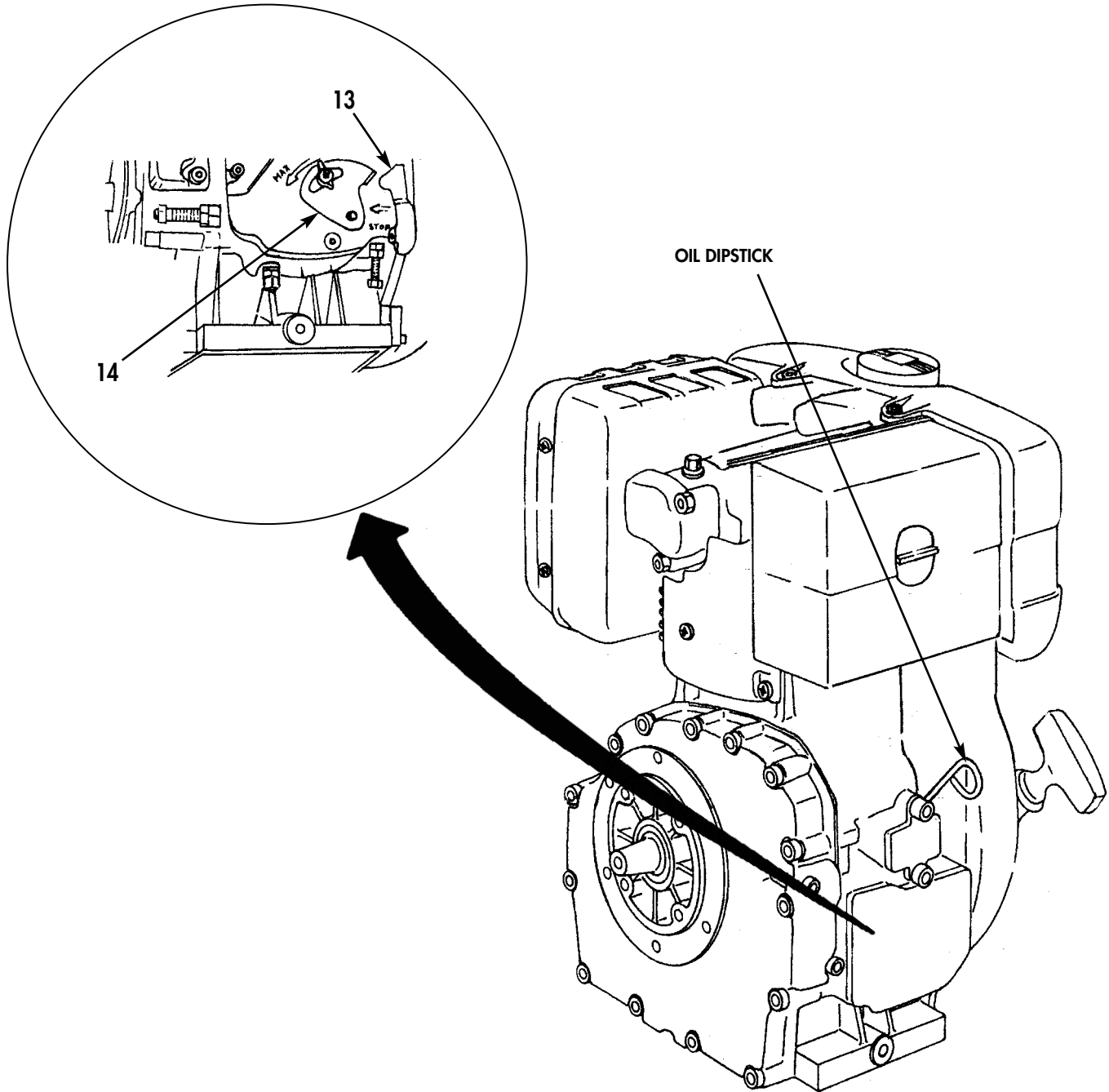

Figure 14. Engine Controls, FAWPSS.

DESCRIPTION AND USE OF OPERATOR CONTROLS AND INDICATORS (Contd)

- 15. PUMP FILL AND DRAIN PLUGS** — There is a fill plug located on the top of the pump casing and a drain plug located on the bottom. To remove either plug, turn the threaded plug to the left (counterclockwise) and remove it from the casing.

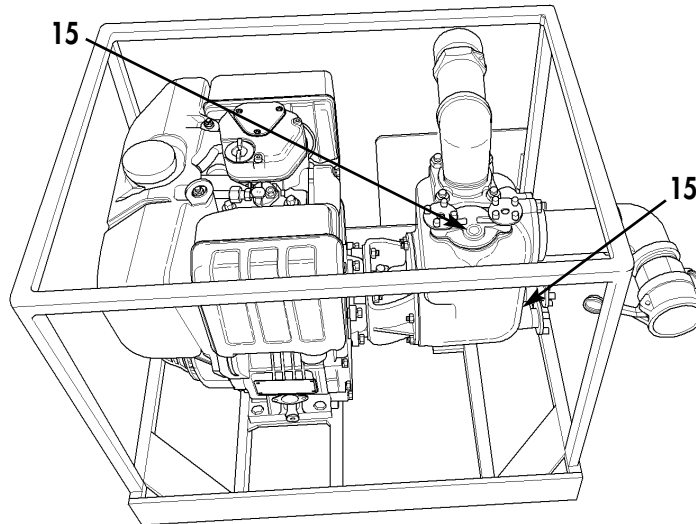

Figure 15. FAWPSS Pump.

- 16. NOZZLE STAND CLEVIS LEGS** — The stand assembly is a collapsible tripod type design containing a hook on each leg to hold up the nozzle when not in use. To set up the stand, hold the stand assembly upright, on a reasonably flat and level surface, and swing two clevis legs out from the pivot leg until the three retaining chains are taut. The nozzles are supported on the stand assembly with the hook between the nozzle's lever and lever guard.

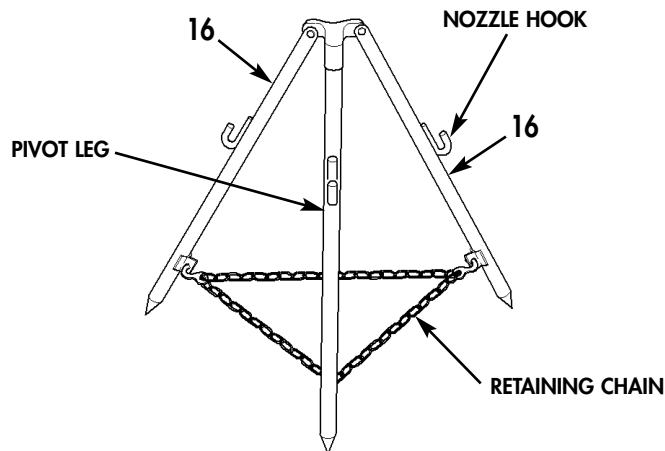

Figure 16. Stand Assembly Legs.

DESCRIPTION AND USE OF OPERATOR CONTROLS AND INDICATORS (Contd)

- 17. NOZZLE LEVER** — The nozzle lever is located between the lever guard and the nozzle housing. The spring-loaded nozzle lever is always in the closed position and will return to the closed position once released. Squeezing the lever will open the valve, and the rate and amount of water expelled from the nozzle is controlled by how far the lever is moved.
- 18. NOZZLE DUST CAP** — There is a removable dust cap designed to cover the nozzle spout when not in use. The cap is held in place by a small chain under spring tension. To remove the cap, simply pull on the cap until it clears the nozzle spout. To install the cap, pull the cap in the direction of the spout until it can be placed over the end of the spout, then release the cap.

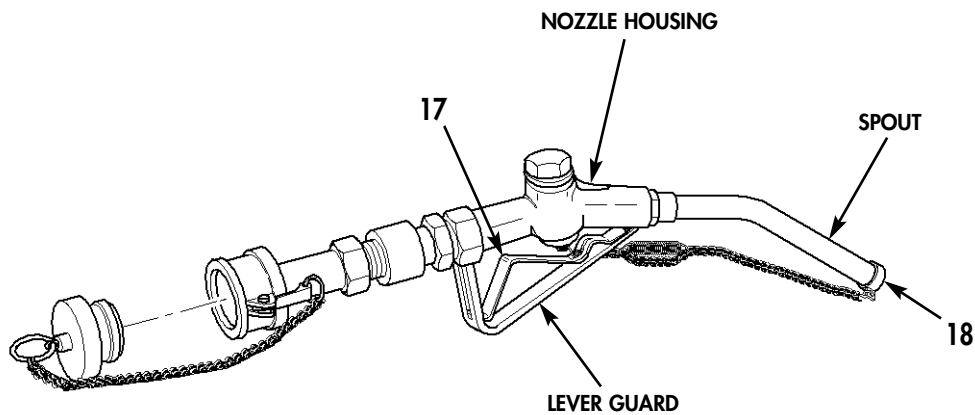

Figure 17. Nozzle Assembly.

END OF WORK PACKAGE

0004-7/8 blank

**OPERATOR INSTRUCTIONS
FORWARD AREA WATER POINT SUPPLY SYSTEM (FAWPSS)
OPERATION UNDER USUAL CONDITIONS**

INITIAL SETUP**References**

TM 10-5430-245-12&P
TM 10-5430-247-13&P

References (Contd)

TM 5-4320-368-14&P

GENERAL

Work packages 0005 through 0011 provide instructions for operation of the FAWPSS under normal operating conditions. For operation under unusual conditions, refer to WP 0012.

This work package provides the operator with instructions to operate the FAWPSS under normal conditions. It describes the process by which the operator will utilize the equipment and the order in which operational tasks are to be performed. Operation under Usual Conditions includes sitting requirements, assembly and preparation for use, operating procedures, decals and instruction plates, operating auxiliary equipment, and preparation for movement. Follow the instructions for each heading listed below.

SITTING REQUIREMENTS

Sitting requirements refer to the conditions necessary to setup the FAWPSS for operation. Before the equipment can be assembled for operation, an approved site location must be determined. Refer to Site Requirements and Layouts, WP 0006.

ASSEMBLY AND PREPARATION FOR USE

The FAWPSS is made up of several individual separate items, and these items have to be identified, laid out, and assembled before the system can be operated. Prior to operation, the operator will perform the following:

1. Review equipment names, use of controls and indicators, and operating instruction work packages before performing mission. Refer to WP 0002, 0004, and 0006 through 0011.
2. Review associated technical manuals for operation and PMCS of the collapsible fabric drum and centrifugal pump unit prior to performing mission. These TMs are required for operation of the FAWPSS. Refer to WP 0044.
3. Refer to Service upon Receipt of Material, WP 0018, and perform the procedures for unloading, unpacking, checking unpacked equipment, installation/assembly instructions, and preliminary servicing of equipment.
4. Ensure unit maintenance has performed the required maintenance per service interval to the pump unit; refer to DA Form 2404/5988-E, Equipment Inspection and Maintenance Worksheet.
5. Layout and assemble the FAWPSS in accordance with (IAW) WP 0007, for FAWPSS Model LAB 9095, or WP 0008, for FAWPSS Model M105.
6. Fill and transport drums IAW WP 0009.

OPERATION UNDER USUAL CONDITIONS (Contd)**OPERATING AUXILIARY EQUIPMENT**

PMCS, operating, and maintenance procedures for the collapsible fabric drums and centrifugal pump unit are not covered in this TM. Refer to TM 10-5430-245-12&P and TM 10-5430-247-13&P for drums and TM 5-4320-368-14&P for pump unit.

DECALS AND INSTRUCTION PLATES

Since the FAWPSS is basically a configuration made up of a number of separate end items assembled for a specific purpose, the system itself does not have a decal or instruction data plate. However, the system will be identified on the wooden shipping crate by NSN. Individual COEI such as the collapsible fabric drum and centrifugal pump unit do have decals and or information plates that can be found in applicable TMs. Refer to References, WP 0044.

INITIAL ADJUSTMENTS, BEFORE USE, AND SELF-TEST

Once the FAWPSS has been assembled and prepared for use, perform all operator Preventive Maintenance Checks and Services (PMCS) prior to operating the equipment.

OPERATING PROCEDURES**WARNING**

Water from FAWPSS must be tested IAW TB MED 577 before use. Failure to comply may result in sickness or death to personnel.

For operation of FAWPSS Model M105, drums will be drained sequentially from rear to front of platform during operation. This requirement is to optimize weight distribution for loading and movement of PLS Flatrack or CROP. Failure to comply may result in damage to equipment or possible injury to personnel.

CAUTION

For operation of FAWPSS Model M105, platform must be unloaded to ground prior to operating FAWPSS. Failure to comply may result in damage to equipment.

NOTE

The following operating procedures cover both models of the FAWPSS.

OPERATION UNDER USUAL CONDITIONS (Contd)**OPERATING PROCEDURES (Contd)**

1. Ensure FAWPSS equipment is properly assembled, and perform all before and during operation PMCS as required. Refer to WP 0016.
2. Open coupler valve (Figure 1, Item 1) on drum (Figure 1, Item 2) selected for use by turning handwheel (Figure 1, Item 3) to the right until locked. Refer to WP 0004.

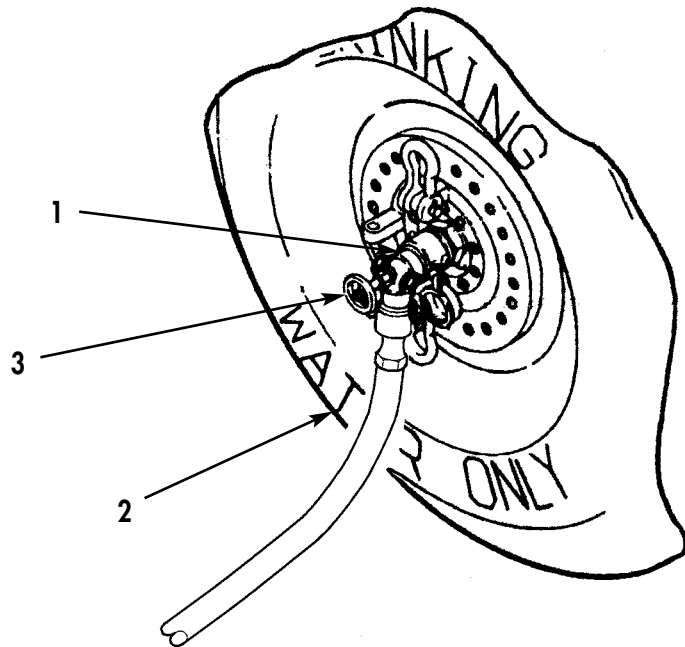

Figure 1. Open Coupling Valve.

3. Open ball valve (Figure 2, Item 2) for drum (Figure 1, Item 2) in use by turning lever (Figure 2, Item 1) until in line with valve body (Figure 2, Item 3). Refer to WP 0004.

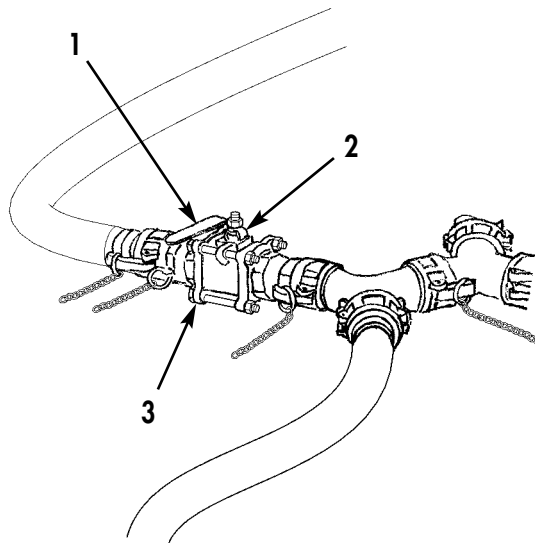

Figure 2. Open Ball Valve.

OPERATION UNDER USUAL CONDITIONS (Contd)**OPERATING PROCEDURES (Contd)****WARNING**

Never operate pump unit in enclosed areas unless exhaust gases are piped outside. Exhaust gases contain carbon monoxide, a colorless, odorless, and poisonous gas, which can cause serious illness or death.

Hearing protection must be worn by all personnel within 20 ft (6.1 m) of an operating pump or long-term hearing loss may result.

CAUTION

Do not operate pump unit dry. Ensure pump unit is primed the first time before starting. Ensure FAWPSS valves are open and water is flowing through hoses connected to pump unit prior to starting. After priming, do not run pump for more than 3 to 5 minutes without water flowing through it or damage to the pump's

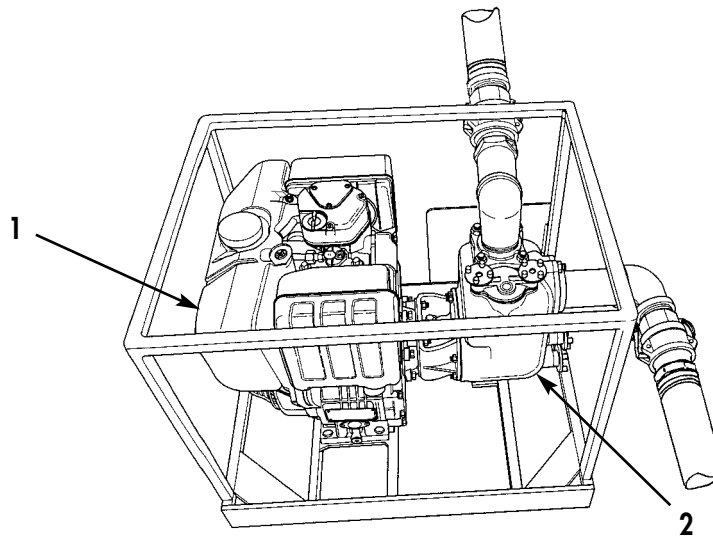

Figure 3. Prime Pump and Start Engine.

5. At any distribution point, remove nozzle assembly (Figure 4, Item 5) from hook (Figure 4, Item 3) on stand (Figure 4, Item 4). Remove nozzle dust cap (Figure 4, Item 7) from spout (Figure 4, Item 6) Refer to WP 0004.

WARNING

When dispensing water for the first time after assembly, operate each nozzle for 30 seconds to flush out any dirt or debris that may have entered the system during assembly. Contaminated water may result in illness to personnel.

NOTE

Water exiting nozzle is under significant pressure. To avoid overflowing container and wasting water, squeeze nozzle lever slowly while observing level in container until full.

OPERATION UNDER USUAL CONDITIONS (Contd)**OPERATING PROCEDURES (Contd)**

6. Place end of spout (Figure 4, Item 6) in filler neck of suitable container and slowly squeeze nozzle lever (Figure 4, Item 8) to dispense water. Release nozzle lever (Figure 4, Item 8) to shut off water.

NOTE

Perform step 7 if operating FAWPSS Model M105.

7. As drum drains, adjust tiedown chains and straps as necessary to allow drum endplates to fold inward. Refer to WP 0009.

WARNING

Always replace dust cap on end of nozzle spout to keep dirt and debris out. Contaminated water may result in illness to personnel.

8. When finished dispensing water, place dust cap (Figure 4, Item 7) on end of nozzle spout (Figure 4, Item 6) and hang nozzle assembly (Figure 4, Item 5) on hook (Figure 4, Item 3) of stand (Figure 4, Item 4).

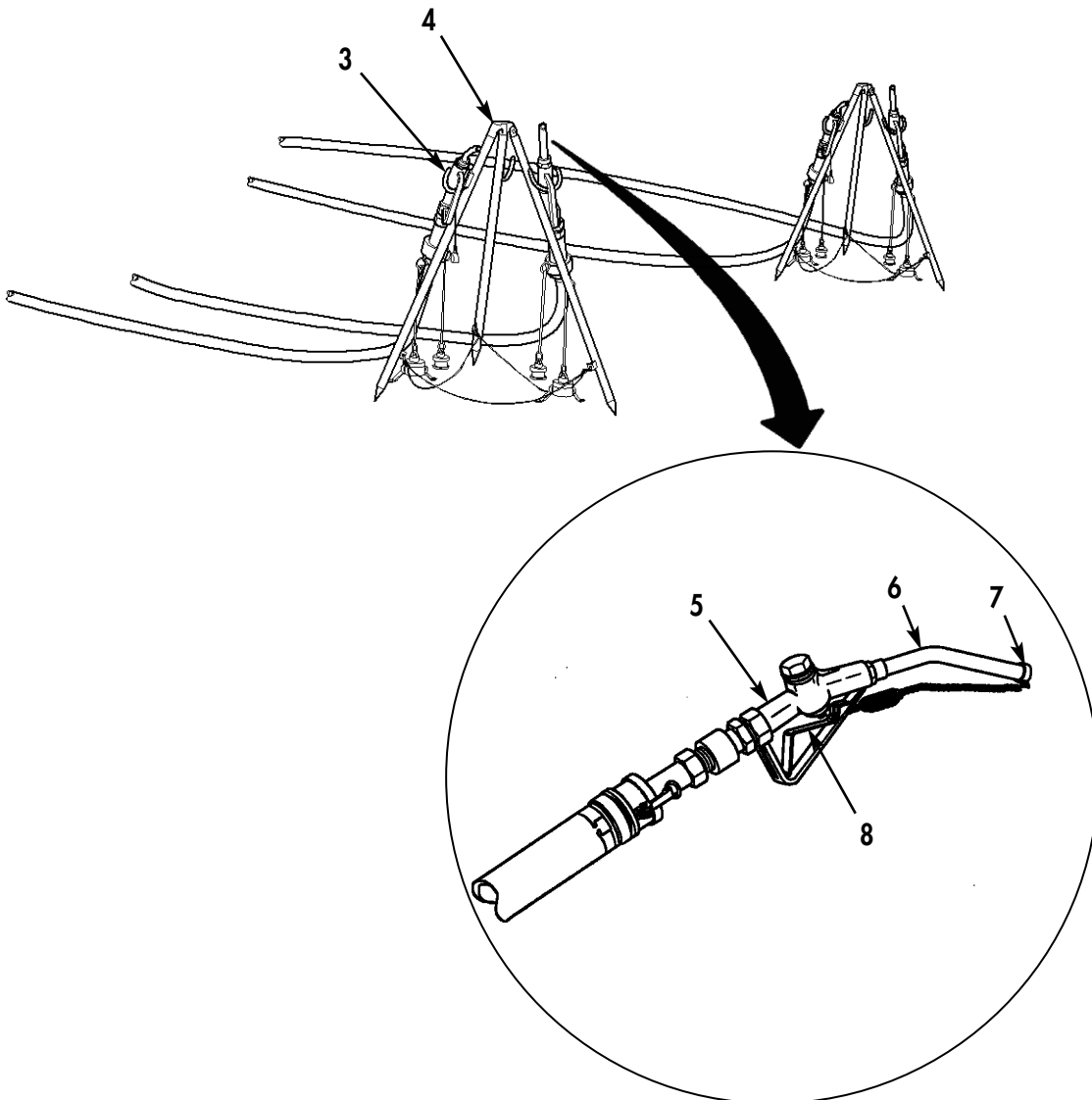

Figure 4. Use of Distribution Point Nozzles.

OPERATION UNDER USUAL CONDITIONS (Contd)**OPERATING PROCEDURES (Contd)****WARNING**

Pump unit engine and exhaust system may be hot enough to cause burns if touched. Use caution when shutting off engine or injury to personnel may result.

9. Shut down pump unit engine (Figure 5, Item 1) by turning start/stop lever to the right. Refer to TM 5-4320-368-14&P.

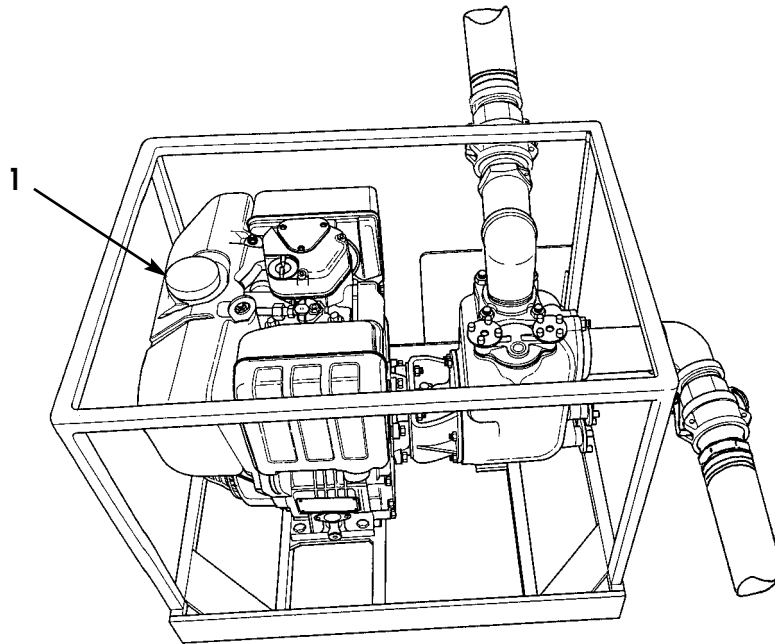

Figure 5. Pump Unit Engine Shutdown.

CAUTION

Freezing water can severely damage FAWPSS equipment. When temperatures are below 32 F (0 C), disconnect each end of all hoses and drain pump casing or damage to equipment may result.

10. If operating in extreme cold, drain water from hoses and pump casing immediately after use. Refer to Operation under Unusual Conditions, WP 0012.
11. Perform all after operation PMCS as required. Refer to WP 0015 and WP 0016.

END OF TASK**PREPARATION FOR MOVEMENT**

Refer to WP 0009 for movement of drums. Refer to WP 0010 for disassembly and movement of FAWPSS Model LAB 9095. Refer to WP 0011 for disassembly and movement of FAWPSS Model M105.

END OF WORK PACKAGE

**OPERATOR INSTRUCTIONS
FORWARD AREA WATER POINT SUPPLY SYSTEM (FAWPSS)
SITE REQUIREMENTS AND LAYOUTS**

INITIAL SETUP: Not Applicable

Site selection for the FAWPSS depends on several factors, and is chiefly the result of a commander's strategic decision based on tactical requirements. Site conditions such as terrain features and specific application will determine the location for construction and operation of the FAWPSS. A careful survey of the proposed site should be made by reconnaissance, not the FAWPSS operator/crewmember. However, the operator/crewmember must understand and observe the site requirements when positioning and preparing the equipment for operation.

1. Reconnaissance requirements

- a. Conduct a site survey to establish a suitable site location prior to allowing the FAWPSS to be transported to the proposed site location. Once determined, the site should be adequately marked out.
- b. Determine if the proposed site is road accessible. If an established road is not present, the area must be accessible by tactical truck. In addition, water distribution points must be easily accessible for the troops.
- c. Determine if the ground conditions and slope of the proposed site are adequate for the required area. Refer to terrain requirements listed below.
- d. If trees or power lines are present, determine if adequate clearance is available for tactical vehicles to navigate. The area must be free of trees and power lines if movement by helicopter will be required.

2. Sitting Requirements

- a. **Location** — The FAWPSS will be located and assembled on a level area such as concrete, asphalt, brick or stone pavers, or earth that is free from debris, large rocks, and sharp gravel. The estimated area required for a fully assembled FAWPSS shall consist of an open space approximately 30 ft x 120 ft (9.2 m x 37 m).
- b. **Proximity to power sources** — The FAWPSS is self-contained for normal operation. Fuel is required to operate the pump unit's engine, which is setup on the ground. Additional fuel is kept in 5-gallon (19 l) cans stowed on the ground. Use of an electrical power source may be necessary for operation of a water chiller.
- c. **Effective ranges** — The FAWPSS can store water siting on the ground or on a PLS Flatrack or CROP in temperatures ranging from 135 F (57.5 C) to -50 F (-45 C) with proper cooling or a heated space as required.
- d. **Terrain requirements** — The FAWPSS will be placed in an area that is relatively level where ground cover is free from dense brush, sharp rocks, and low hanging trees and power lines. An overhead clearance of at least 22 ft, 2 in. (6.7 m) is required for off-loading of equipment on a PLS Flatrack or CROP. The site will also be located in an area above a known flood plain should periods of heavy rainfall occur.

WARNING

Water from FAWPSS must be tested IAW TB MED 577 before use.
Failure to comply may result in sickness or death to personnel.

- e. **Technical requirements** – Water from FAWPSS must be tested IAW TB MED 577 before use.

SITE REQUIREMENTS AND LAYOUTS (Contd)**2. Sitting Requirements (Contd)****WARNING**

EXHAUST GASES CAN KILL. Never operate the centrifugal pump engine in an enclosed area unless exhaust gases are piped to the outside. Engine exhaust gases contain carbon monoxide, a colorless, odorless, and poisonous gas that can cause unconsciousness and death if inhaled. THE BEST DEFENSE AGAINST CARBON MONOXIDE POISONING IS ADEQUATE VENTILATION. If you experience any of the following symptoms, get out into fresh air immediately: dizziness, intense headache, weakness, sleepiness, muscular twitching, throbbing in temples, or vomiting. Failure to comply may result in injury or death to personnel.

- f. **Shelter locations** — The FAWPSS is designed to be assembled and operated out-of-doors and will normally not be housed during use. In warm climates, the FAWPSS will be kept out of direct sunlight by covering with tarps, tents, or by utilizing natural ground cover or terrain equipment, whichever is available. In below freezing climates the FAWPSS must be kept in a heated space after use. This will require immediate draining of water from hoses, valves, and pump after use, and drums must be enclosed by tent and heated, or moved to a heated building, or drained.

WARNING

Hazards to personnel and equipment are increased if the FAWPSS is utilized when site conditions are undesirable or not properly prepared. The site must be inspected and properly prepared prior to setup and operation. Failure to adequately prepare the site could result in damage to equipment or possible injury to personnel.

- g. **Compensating for adverse sitting conditions** — Ground conditions may be improved by either removing large stones and filling in low spots or grading and filling the entire site until the ground surface is approximately level.
- h. **Mobile equipment oriented during installation** — The FAWPSS Model M105 will require space to unload/load a PLS Flatrack or CROP. Model LAB 9095 will require an area accessible by water tanker truck and ground conditions conducive to moving and positioning filled drums.

3. Local Weather Conditions

- a. Ensure the possibility of heavy rainfall would not result in flooding or soil erosion problems at the proposed site.
- b. Ensure the strength and direction of prevailing winds will not hamper assembly, filling, and operation of the FAWPSS. In strong winds, FAWPSS drums will require that they be secured with tiedowns. Refer to WP 0012.

END OF TASK**END OF WORK PACKAGE**

OPERATOR INSTRUCTIONS
FORWARD AREA WATER POINT SUPPLY SYSTEM (FAWPSS)
ASSEMBLY AND PREPARATION FOR USE – MODEL LAB 9095
EFFECTIVE NOTICE
Model LAB 9095

INITIAL SETUP**Materials/Parts**

Gaskets as required (WP 0032 Items 3, and 11)

Personnel Required

Two

Equipment Condition

Approved site located (WP 0006).
FAWPSS unpacked, inventoried, and pump fittings installed (WP 0018).

WARNING

Hazards to personnel and equipment are increased if the FAWPSS is utilized when site conditions are undesirable or not properly prepared. The site must be inspected and properly prepared prior to setup and operation. Failure to adequately prepare the site could result in damage to equipment or possible injury to personnel.

NOTE

The location and layout of FAWPSS components will be determined based on the site survey. Ensure the approved site is properly prepared prior to assembly. Refer to WP 0006.

1. Plan the most efficient layout for the selected site by making the best use of natural cover and level terrain. An open area approximately 30 ft x 120 ft (9.2 m x 37 m) should be utilized. Ensure storage drums and distribution points are located where they will be easily accessible.

WARNING

Ensure all quick-disconnect coupling caps and plugs remain on major components, hoses, and fittings until they are connected into the system. Failure to comply may result in contamination entering system and possible injury to personnel.

CAUTION

Sharp objects or rough terrain can cause punctures in storage drums and hoses. When positioning empty or filled drums and hoses on ground, ensure area is free from debris and sharp rocks, and do not allow vehicles to drive over hoses or damage to equipment may result.

ASSEMBLY AND PREPARATION FOR USE — MODEL LAB 9095 (Contd)

CAUTION

Do not tow filled storage drums over sharp objects or rough terrain, and do not exceed 10 mph (16 km/hr) when towing drums. Failure to comply may result in damage to drums.

NOTE

If storage drums arrive filled and will require positioning at the site, the towing and lifting yoke must be used. Refer to WP 0009 for instructions.

- Place two storage drums (Figure 1, Item 4), pump unit (Figure 1, Item 1), and two nozzle stand assemblies (Figure 1, Item 2) on ground in their approximate locations for desired layout.

NOTE

Perform step 3 if empty drums will be filled at site.

- Install coupler valve (Figure 1, Item 3) on each drum, and fill two drums (Figure 1, Item 4) with potable water IAW filling instructions. Refer to WP 0009.

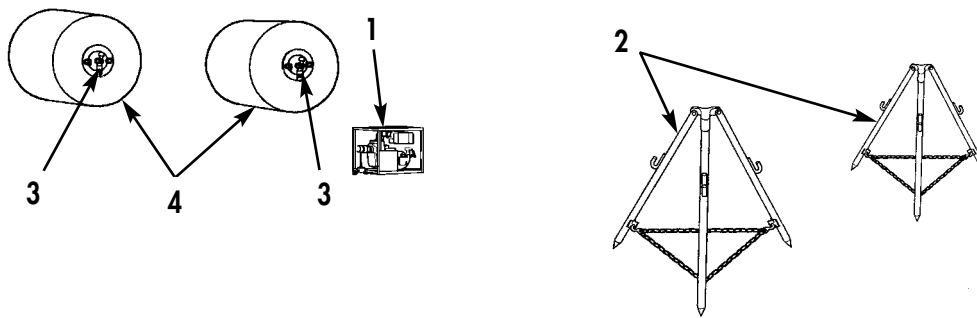
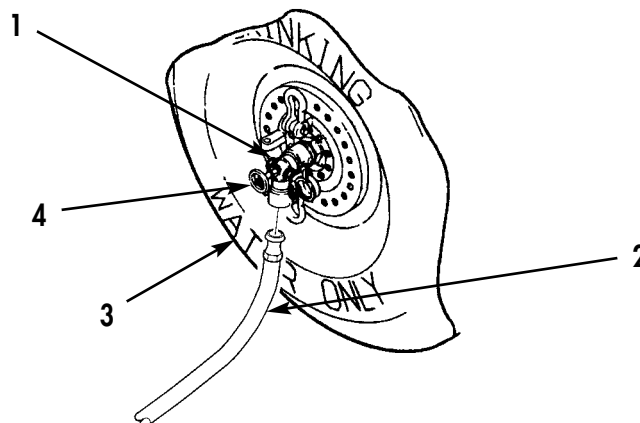

Figure 1. Placement of FAWPSS Components.

CAUTION

When connecting quick-disconnect couplings, ensure a gasket is present or leaking will result. Once connected, ensure coupling dust caps and plugs are connected together to prevent contamination, loss of gasket, and damage to mating surfaces.

- Remove cap from male coupling (Figure 2, Item 4), and connect 2 in. (51 mm) DIA x 10 ft (3 m) long suction hose assembly (Figure 2, Item 2) to coupler valve (Figure 2, Item 1) on two drums (Figure 2, Item 3).



ASSEMBLY AND PREPARATION FOR USE — MODEL LAB 9095 (Contd)

5. Remove plug and cap, and connect ball valve (Figure 3, Item 3) to 2 in. (51 mm) DIA x 10 ft (3 m) long hose assembly (Figure 3, Item 1) on two drums.
6. Remove two plugs and caps, and connect Y-fitting (Figure 3, Item 2) to two ball valves (Figure 3, Item 3).
7. Remove plug and cap, and connect male adapter (Figure 3, Item 5) and 2 in. (51 mm) DIA x 10 ft (3 m) long suction hose assembly (Figure 3, Item 4) to Y-fitting (Figure 3, Item 2).

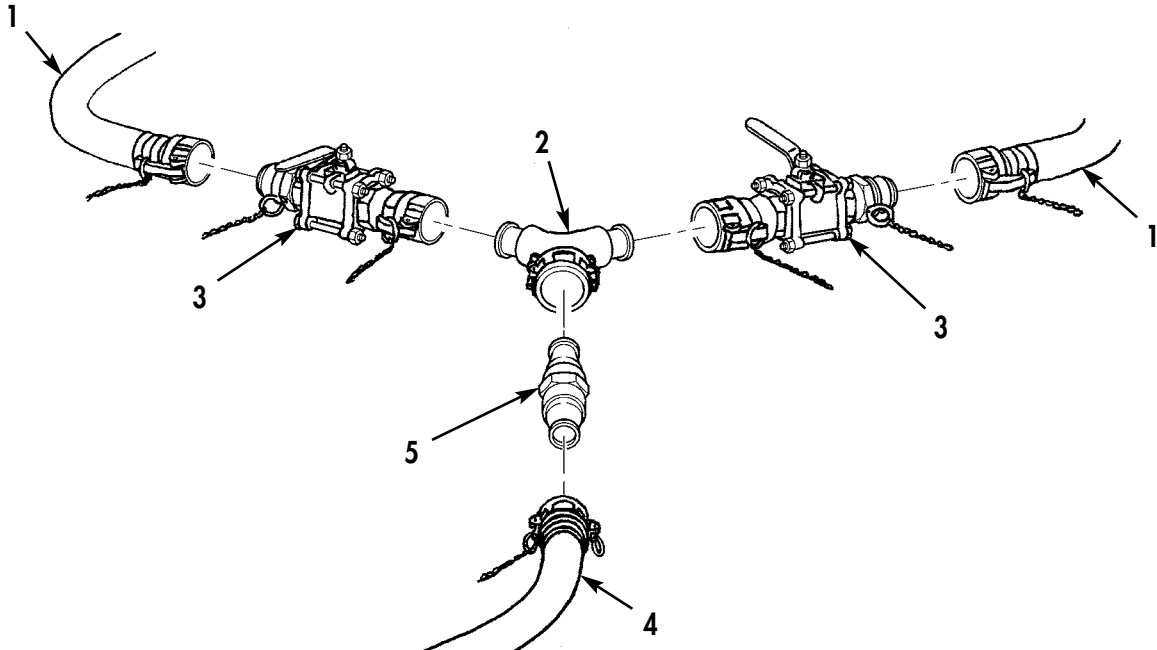

Figure 3. Ball Valve Connections.

8. Position pump unit (Figure 4, Item 4) approximately 15 ft (4.6 m) from drums with FQD coupling (Figure 4, Item 1) facing drums.
9. Remove plug and cap, and connect 2 in. (51 mm) DIA x 10 ft (3 m) long suction hose assembly (Figure 4, Item 3) to FQD coupling (Figure 4, Item 2) on suction port (Figure 4, Item 1) of pump (Figure 4, Item 4).

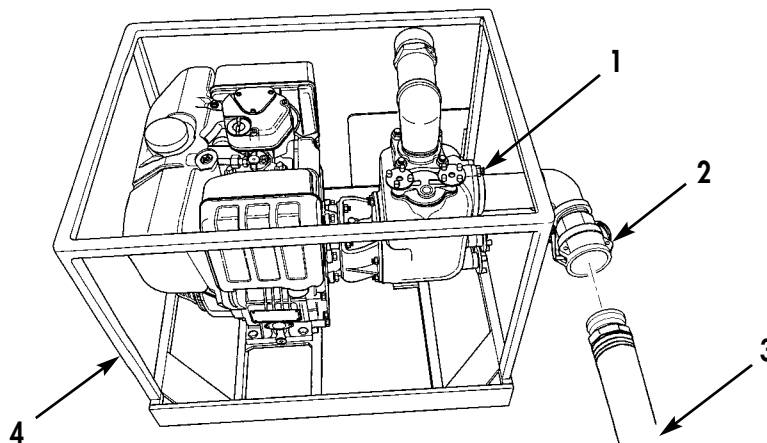

Figure 4. Suction Hose Connection.

ASSEMBLY AND PREPARATION FOR USE — MODEL LAB 9095 (Contd)

10. Remove cap and plug, and connect 2 in. (51 mm) DIA x 10 ft (3 m) long discharge hose assembly (Figure 5, Item 3) to MQD coupling (Figure 5, Item 2) on discharge port (Figure 5, Item 4) of pump (Figure 5, Item 1).

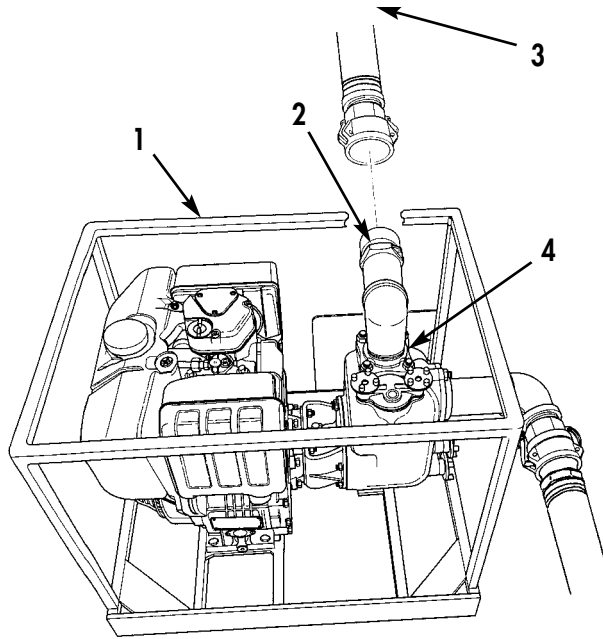

Figure 5. Discharge Hose Connection.

11. Remove plug and cap, and connect Y-fitting (Figure 6, Item 3) to 2 in. (51 mm) DIA x 10 ft (3 m) long discharge hose assembly (Figure 6, Item 1).
12. Remove two plugs and caps, and connect two 2 in. (51 mm) DIA x 25 ft (7.6 m) long discharge hose assemblies (Figure 6, Item 2) to Y-fitting (Figure 6, Item 3).

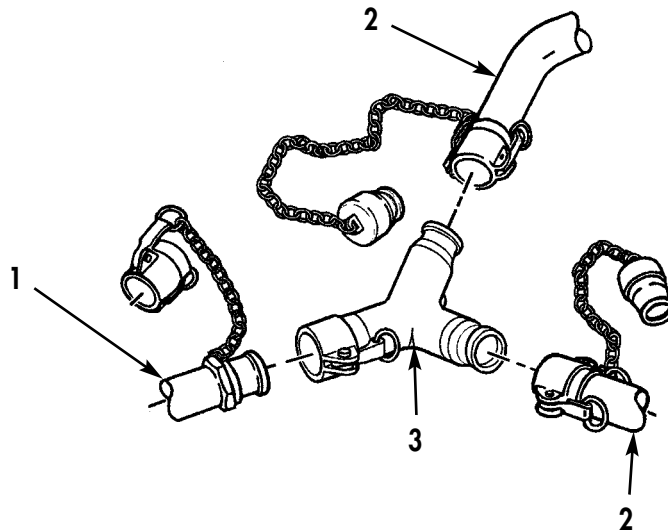

Figure 6. Hose Connections to Y-Fitting.

ASSEMBLY AND PREPARATION FOR USE — MODEL LAB 9095 (Contd)

13. Remove two plugs and caps, and connect two Y-fittings (Figure 7, Item 3) to two 2 in. (51 mm) DIA x 25 ft (7.6 m) long discharge hose assemblies (Figure 7, Item 2).
14. Remove four plugs and caps, and connect four 2 in. to 1.5 in. DIA (51 mm to 38 mm DIA) reducers (Figure 7, Item 4) to two Y-fittings (Figure 7, Item 3).
15. Remove four plugs and caps, and connect four 1.5 in. (38 mm) DIA x 25 ft (7.6 m) long hoses (Figure 7, Item 1) to four reducers (Figure 7, Item 4).

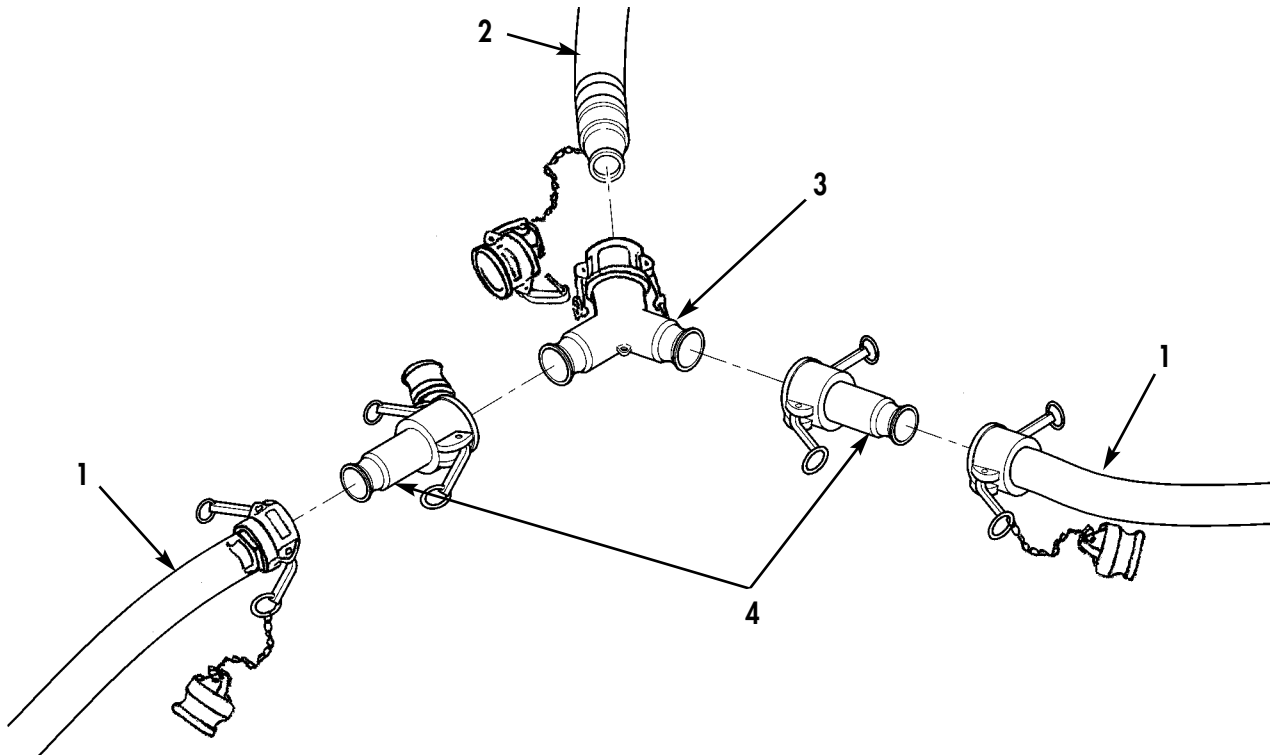

Figure 7. Hose Connections to Y-Fitting and Reducers.

16. Remove four plugs and caps, and connect four nozzle assemblies (Figure 8, Item 3) to four 1.5 in. (38 mm) DIA x 25 ft (7.6 m) long hoses (Figure 8, Item 1).
17. Set up nozzle stand assembly (Figure 8, Item 2), and secure two nozzle assemblies (Figure 8, Item 3) to hooks (Figure 8, Item 4) on stand assembly (Figure 8, Item 2) at two distribution points.
18. Refer to WP 0005 for operating instructions prior to operation of FAWPSS.

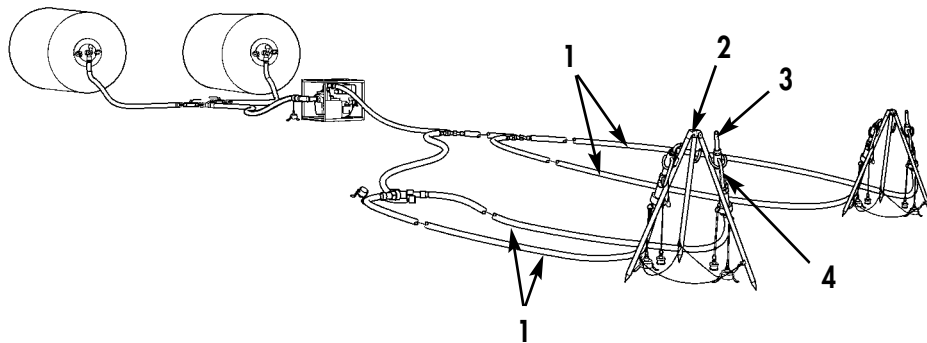

Figure 8. Hose Connections to Nozzles.

END OF TASK

END OF WORK PACKAGE

OPERATOR INSTRUCTIONS
FORWARD AREA WATER POINT SUPPLY SYSTEM (FAWPSS)
ASSEMBLY AND PREPARATION FOR USE – MODEL M105
EFFECTIVE NOTICE
 Model M105

INITIAL SETUP
Materials/Parts

Gaskets as required (WP 0032 Items 3, and 11)

Personnel Required

Two

Equipment Condition

Approved site located (WP 0006).

Flatrack or CROP unloaded to ground
(WP 0009).

FAWPSS unpacked, inventoried, and pump
fittings installed (WP 0018).

WARNING

Hazards to personnel and equipment are increased if the FAWPSS is utilized when site conditions are undesirable or not properly prepared. The site must be inspected and properly prepared prior to setup and operation. Failure to adequately prepare the site could result in damage to equipment or possible injury to personnel.

NOTE

The location and layout of FAWPSS components will be determined based on the site survey. Ensure the approved site is properly prepared prior to assembly. Refer to WP 0006.

1. Plan the most efficient layout for the selected site by making the best use of natural cover and level terrain. An open area approximately 30 ft x 120 ft (9.2 m x 37 m) should be utilized. Ensure storage drums and distribution points are located where they will be easily accessible.

WARNING

Ensure all quick-disconnect coupling caps and plugs remain on major components, hoses, and fittings until they are connected into the system. Failure to comply may result in contamination entering system and possible injury to personnel.

CAUTION

Sharp objects or rough terrain can cause punctures in hoses. When hoses are positioned on ground, ensure area is free from debris and sharp rocks, and do not allow vehicles to drive over hoses or damage to equipment may result.

ASSEMBLY AND PREPARATION FOR USE — MODEL M105 (Contd)

WARNING

If PLS Flatrack or CROP containing storage drums will be repositioned at the site or removed for refilling of drums, FAWPSS equipment must be cleared from vehicle path and all personnel must stand clear or damage to equipment and possible injury or death to personnel may result.

2. Ensure position of storage drums (Figure 1, Item 3) is adequate for assembly of FAWPSS. Refer to WP 0009 for positioning of PLS Flatrack or CROP containing FAWPSS storage drums (Figure 1, Item 3) and shipping crate.
3. Place pump unit (Figure 1, Item 1) and two nozzle stand assemblies (Figure 1, Item 2) on the ground in their approximate locations for the desired layout.

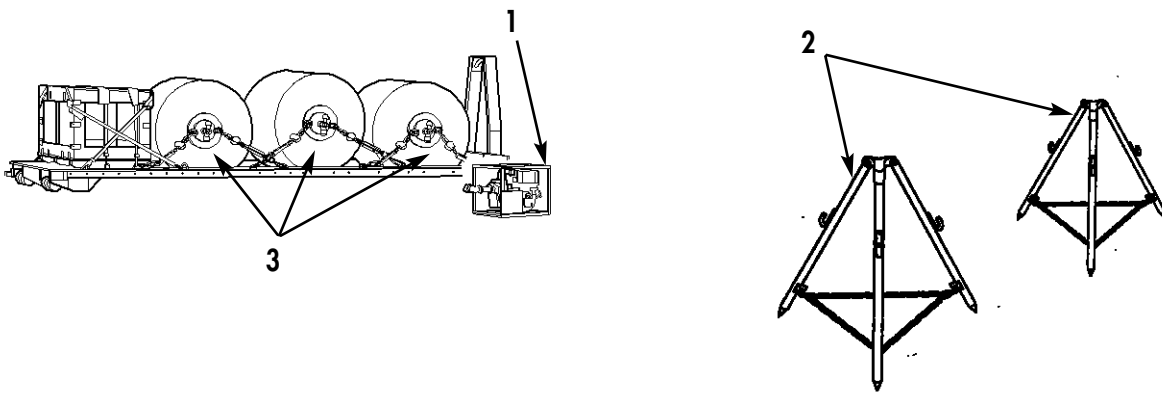

Figure 1. Placement of FAWPSS Components.

CAUTION

When connecting quick-disconnect couplings, ensure a gasket is present or leaking will result. Once connected, ensure coupling dust caps and plugs are connected together to prevent contamination, loss of gasket, and damage to mating surfaces.

4. Install three coupler valves (Figure 2, Item 1) on drums (Figure 2, Item 3). Refer to WP 0009.
5. Remove cap from male coupling (Figure 2, Item 4), and connect 2 in. (51 mm) DIA x 10 ft (3 m) long suction hose assembly (Figure 2, Item 2) to coupler valve (Figure 2, Item 1) on three drums (Figure 2, Item 3).

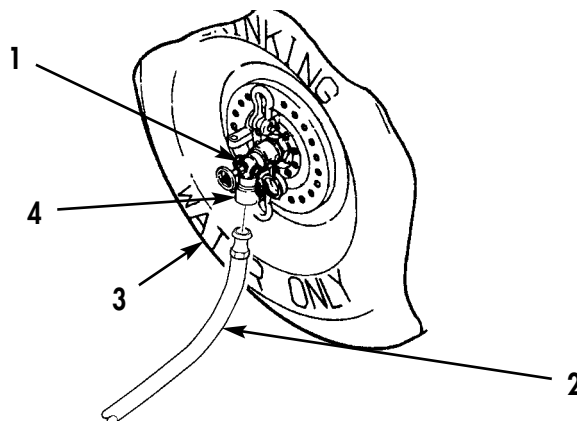

Figure 2. Connecting to Coupler Valve.

ASSEMBLY AND PREPARATION FOR USE — MODEL M105 (Contd)

6. Remove plug and cap, and connect ball valve (Figure 3, Item 2) to 2 in. (51 mm) DIA x 10 ft (3 m) long hose assembly (Figure 3, Item 1) on three drums.
7. Remove plug and cap, and connect two Y-fittings (Figure 3, Item 3) together.
8. Remove three plugs and caps, and connect three ball valves (Figure 3, Item 2) to two Y-fittings (Figure 3, Item 3).
9. Remove plug and cap, and connect male adapter (Figure 3, Item 5) and 2 in. (51 mm) DIA x 10 ft (3 m) long suction hose assembly (Figure 3, Item 4) to Y-fitting (Figure 3, Item 3).

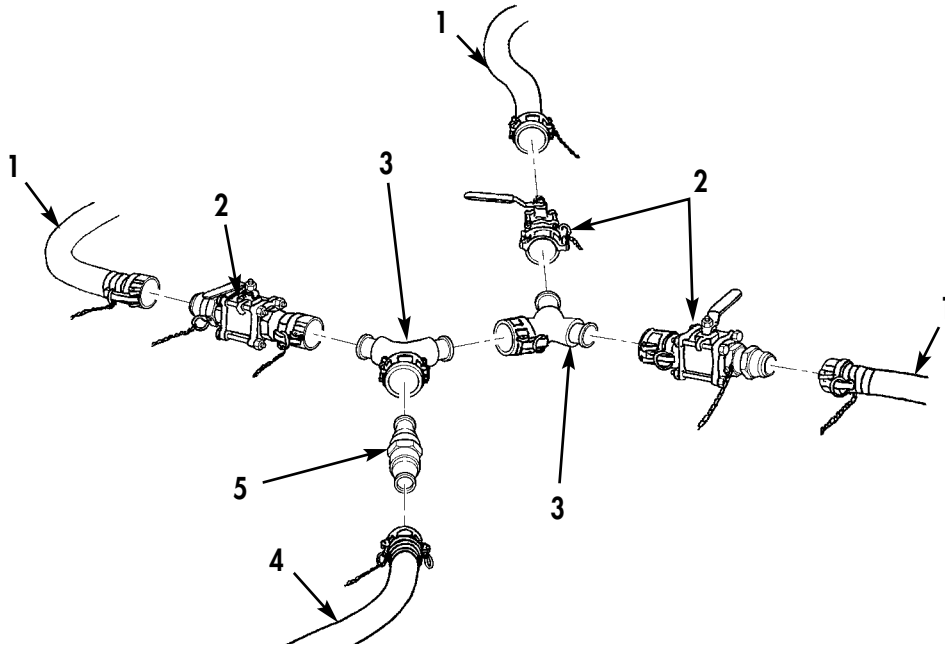

Figure 3. Ball Valve Connections.

10. Position pump unit (Figure 4, Item 1) approximately 15 ft (4.6 m) from drums with FQD coupling (Figure 4, Item 3) facing drums.
11. Remove plug and cap, and connect 2 in. (51 mm) DIA x 10 ft (3 m) long suction hose assembly (Figure 4, Item 4) to FQD coupling (Figure 4, Item 3) on suction port (Figure 4, Item 2) of pump (Figure 4, Item 1).

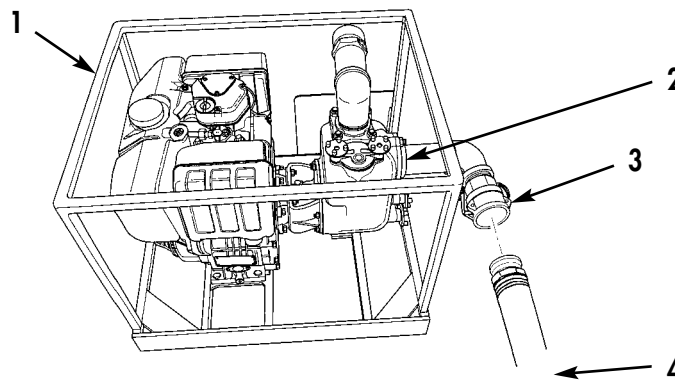

Figure 4. Suction Hose Connection.

ASSEMBLY AND PREPARATION FOR USE — MODEL M105 (Contd)

12. Remove cap and plug, and connect 2 in. (51 mm) DIA x 10 ft (3 m) long discharge hose assembly (Figure 5, Item 2) to MQD coupling (Figure 5, Item 1) on pump discharge port (Figure 5, Item 3).

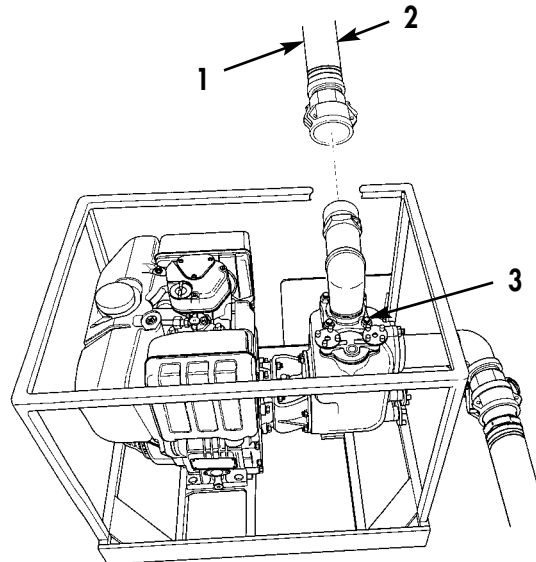

Figure 5. Discharge Hose Connection.

13. Remove plug and cap, and connect Y-fitting (Figure 6, Item 3) to 2 in. (51 mm) DIA x 10 ft (3 m) long discharge hose assembly (Figure 6, Item 1).
14. Remove two plugs and caps, and connect two 2 in. (51 mm) DIA x 25 ft (7.6 m) long discharge hose assemblies (Figure 6, Item 3) to Y-fitting (Figure 6, Item 3).

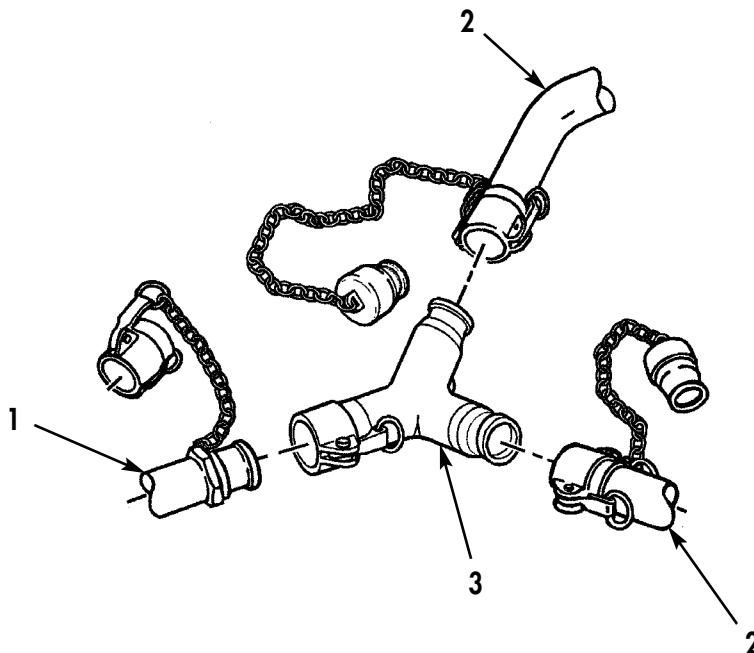

Figure 6. Hose Connections to Y-Fitting.

ASSEMBLY AND PREPARATION FOR USE — MODEL M105 (Contd)

15. Remove two plugs and caps, and connect two Y-fittings (Figure 7, Item 3) to two 2 in. (51 mm) DIA x 25 ft (7.6 m) long discharge hose assemblies (Figure 7, Item 2).
16. Remove four plugs and caps, and connect four 2 in. to 1.5 in. DIA (51 mm to 38 mm DIA) reducers (Figure 7, Item 4) to two Y-fittings (Figure 7, Item 3).
17. Remove four plugs and caps, and connect four 1.5 in. (38 mm) DIA x 25 ft (7.6 m) long hoses (Figure 7, Item 1) to four reducers (Figure 7, Item 4).

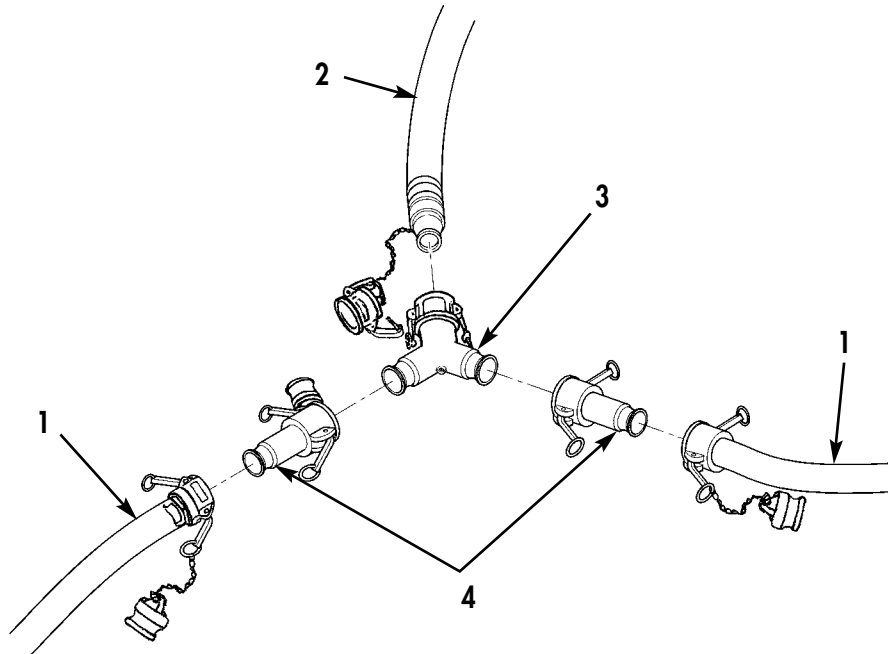

Figure 7. Hose Connections to Y-Fittings and Reducers.

18. Remove four plugs and caps, and connect four nozzle assemblies (Figure 8, Item 3) to four 1.5 in. (38 mm) DIA x 25 ft (7.6 m) long hoses (Figure 8, Item 1).
19. Set up nozzle stand assembly (Figure 8, Item 2), and secure two nozzle assemblies (Figure 8, Item 3) to hooks (Figure 8, Item 4) on stand assembly (Figure 8, Item 2) at two distribution points.
20. Refer to WP 0005 for operating instructions prior to operation of FAWPSS.

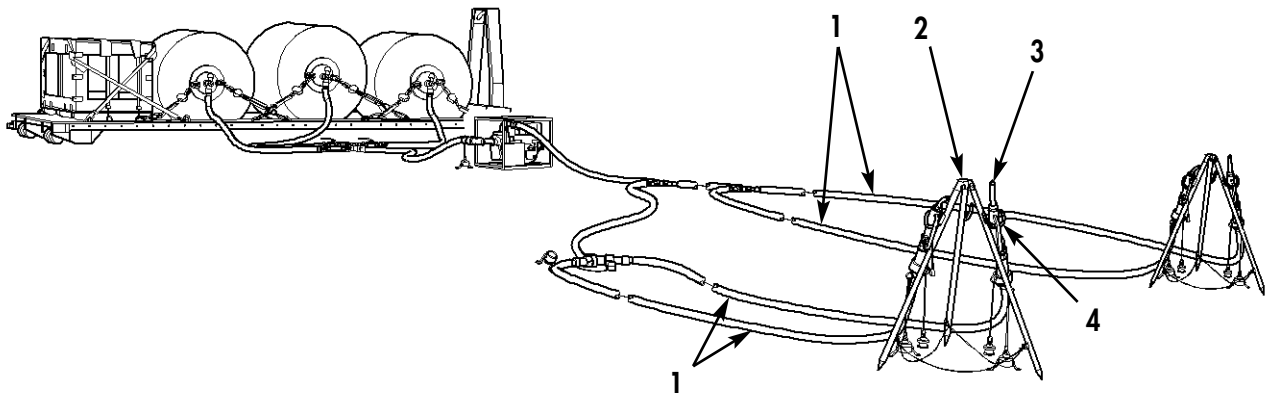

Figure 8. Hose Connections to Nozzles.

END OF TASK

END OF WORK PACKAGE

OPERATOR INSTRUCTIONS
FORWARD AREA WATER POINT SUPPLY SYSTEM (FAWPSS)
FILLING AND MOVEMENT OF DRUMS

INITIAL SETUP**Materials/Parts**

Two locknuts (WP 0036, Item 11)
Tie straps (WP 0049, Item 8)
Drum repair kit (WP 0038)

References

TM 10-5430-245-12&P
TM 10-5430-247-13&P

Personnel Required

Two

FILLING DRUMS**WARNING**

This drum is only authorized to be filled with DRINKING WATER. The drum is designed and permanently labeled for use with DRINKING WATER ONLY. Filling drum with any other liquid may result in sickness or death to personnel.

CAUTION

Sharp objects or rough terrain can cause punctures in storage drums. When positioning and filling drums on ground, flatrack, or truck, ensure area under drums is free from debris and sharp rocks or damage to equipment may result.

When connecting quick-disconnect couplings at coupler valve, ensure a gasket is present or leaking will result. Once connected, ensure coupling dust caps and plugs are connected together to prevent contamination, loss of gasket, and damage to mating surfaces.

To avoid damage to the drum, DO NOT overfill.

NOTE

Use the services of Unit Maintenance for the original unpacking and inspection.

1. Perform Before Operations Preventive Maintenance Checks and Services (PMCS). Refer to TM 10-5430-245-12&P or TM 10-5430-247-13&P.

WARNING

Ensure drum is securely positioned to avoid slipping or rolling during filling operations. Failure to comply may result in damage to equipment or injury to personnel.

CAUTION

Do not tow if drum has been repaired. Towing drum could further damage drum.

2. Locate drum near source of water supply. Choose a site as level and firm as possible. Refer to Site Requirements and Layouts, WP 0006.

FILLING AND MOVEMENT OF DRUMS (Contd)

FILLING DRUMS (Contd)

3. Completely remove air from drum as follows:

- a. At one end of drum, remove dust cap (Figure 1, Item 1) from adapter assembly (Figure 1, Item 2).
- b. Slide coupler valve (Figure 1, Item 3) on adapter assembly (Figure 1, Item 2). Lock coupler valve on adapter assembly (Figure 1, Item 2) by pushing in both cam arms (Figure 1, Item 4).

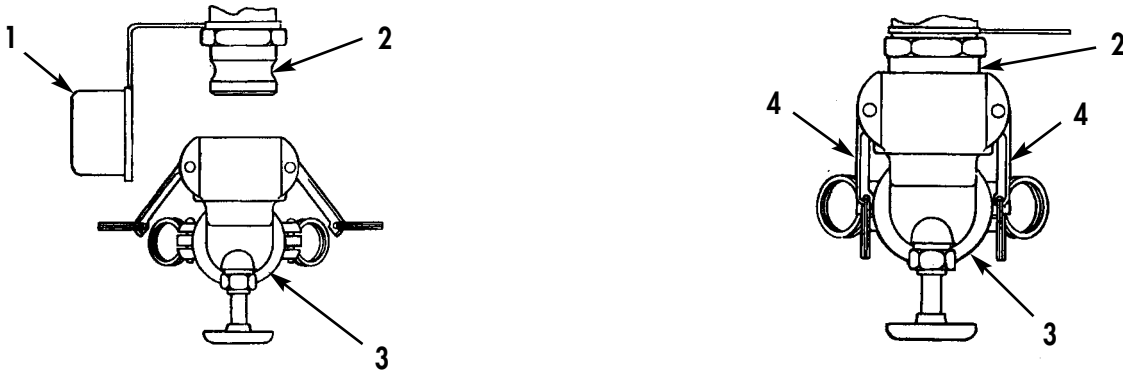

Figure 1. Coupler Valve Installed and Locked onto Adapter Assembly.

- c. Turn handwheel (Figure 2, Item 5) counterclockwise all the way to completely open coupler valve (Figure 2, Item 3).

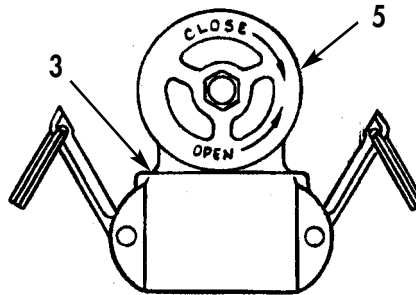

Figure 2. Collapse Drum.

NOTE

Ensure as much air as possible is removed from drum to allow room for entire 500 gallons of water to enter.

- d. Fully collapse drum (Figure 3, Item 6). Push down on drum (Figure 3, Item 6) to squeeze air out. Trapped air will rush out of the coupler valve (Figure 3, Item 3).

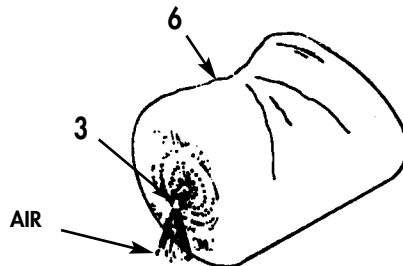

Figure 3. Drum Collapse.

FILLING AND MOVEMENT OF DRUMS (Contd)

FILLING DRUMS (Contd)

- e. When drum is fully collapsed, close coupler valve (Figure 2, Item 3) by turning handwheel (Figure 2, Item 5) clockwise, then unlock and remove coupler valve (Figure 5, Item 3) from adapter assembly (Figure 4, Item 2) by pulling out cam arms (Figure 4, Item 4).

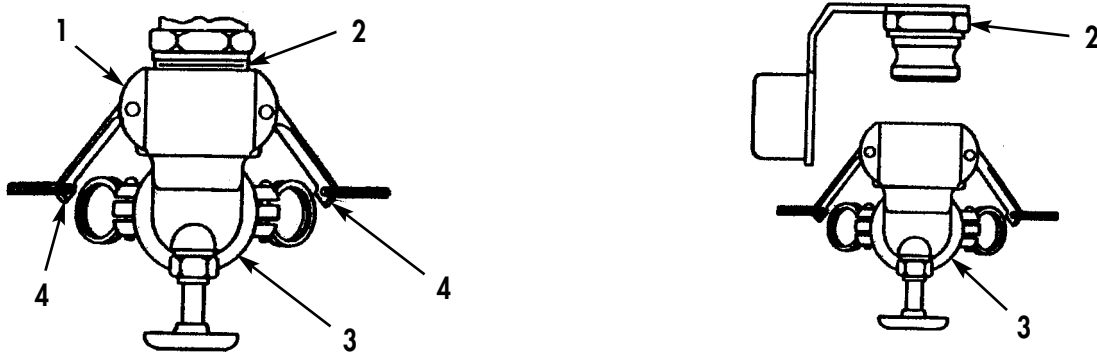

Figure 4. Unlock and Remove Coupler Valve.

4. Connect and lock coupler valve (Figure 5, Item 3) to drinking water supply hose (Figure 5, Item 7) as shown.

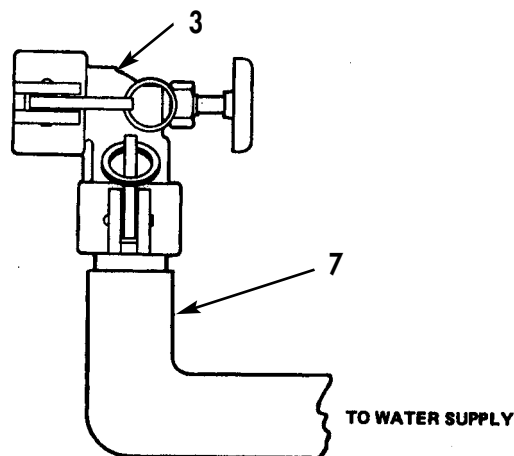

Figure 5. Locking Valve to Filler Hose.

FILLING AND MOVEMENT OF DRUMS (Contd)**FILLING DRUMS (Contd)**

5. Remove air from drinking water supply hose (Figure 6, Item 3) as follows:
 - a. With coupler valve (Figure 6, Item 1) locked on supply hose (Figure 6, Item 3), turn handwheel (Figure 6, Item 2) clockwise all the way until coupler valve (Figure 6, Item 1) is closed.
 - b. Turn handwheel (Figure 6, Item 2) counterclockwise two turns to slightly open coupler valve (Figure 6, Item 1).
 - c. Open valve at source of drinking water supply.
 - d. When only water flows from coupler valve (Figure 6, Item 1), turn handwheel (Figure 6, Item 2) clockwise all the way until coupler valve (Figure 6, Item 2) is closed.

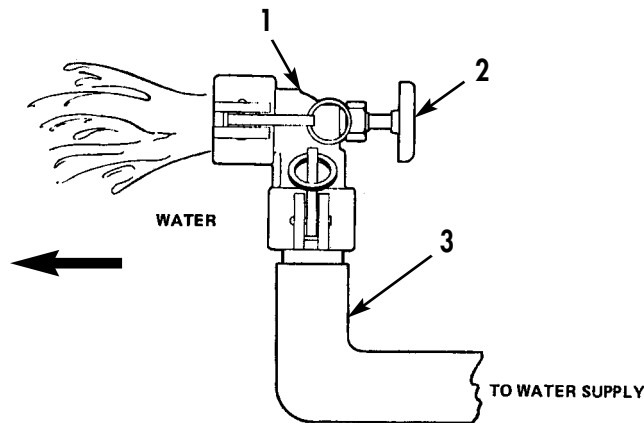

Figure 6. Remove Air from Filler Hose.

6. Connect and lock coupler valve (Figure 9, Item 1) to adapter assembly (Figure 9, Item 4).

NOTE

Refer to figures 7 and 8 when filling drums. A partially filled drum will appear out-of-round, have a large ground contact area, and cannot be rolled. A full drum will appear round, have a small ground contact area, and can be rolled on ground.

CAUTION

To avoid damage to the drum **DO NOT** overfill.

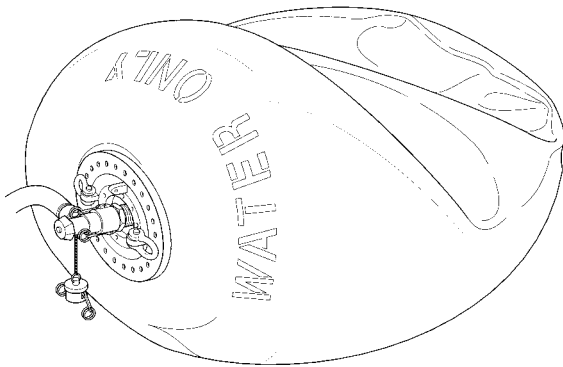

Figure 7. Partially Filled Drum.

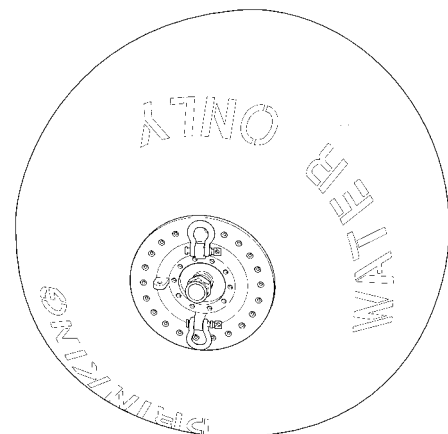

Figure 8. Full Drum.

FILLING AND MOVEMENT OF DRUMS (Contd)**FILLING DRUMS (Contd)**

7. Turn handwheel (Figure 9, Item 2) counterclockwise all the way to open coupler valve (Figure 9, Item 1), and allow drum (Figure 9, Item 5) to fill with drinking water.
8. When drum is approximately full, turn handwheel (Figure 9, Item 2) all the way clockwise until coupler valve (Figure 9, Item 1) is closed.
9. Unlock and remove coupler valve (Figure 9, Item 1) from adapter assembly (Figure 9, Item 4).
10. Install one coupler valve (Figure 9, Item 1) on adapter assembly (Figure 9, Item 4) at end of filled drum.

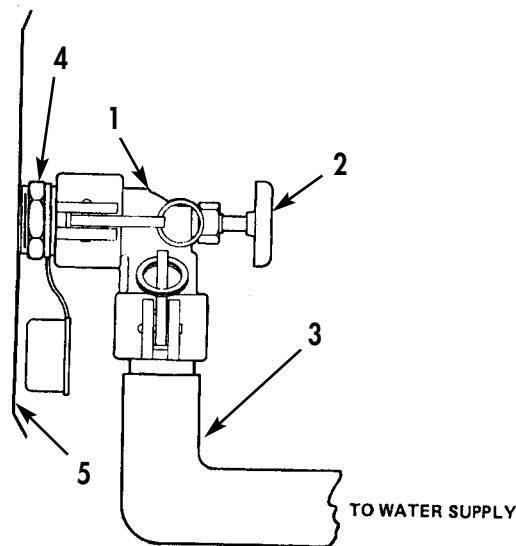

Figure 9. Filling Drum with Drinking Water.

11. Repeat steps 3 through 10 for each drum to be filled.

CAUTION

Each drum comes with two coupler valves. After drum is filled, leave both coupler valves installed on drum except during transportation. Remove coupler valves from drum prior to transporting to prevent damage to valves. During transport, coupler valves must remain with drum so they are not lost. Be sure coupler valves are protected from dirt and other foreign matter when not installed on drum.

12. When the last drum has been filled, shut off valve at drinking water source and disconnect supply hose (Figure 9, Item 3) from coupler valve (Figure 9, Item 1). Leave coupler valve installed on drum. Install second coupler valve on drum at opposite end.

END OF TASK

FILLING AND MOVEMENT OF DRUMS (Contd)**DISPENSING DRINKING WATER FROM DRUM****CAUTION**

Do not overload transport vehicle with filled drums. A filled drum weighs approximately 4,344 pounds (1974.5 kg). Check transport vehicle's weight limits before loading with drums.

Do not tow drum using towing and lifting yoke if drum has been repaired. Towing could further damage drum.

1. Roll, tow or otherwise transport filled drum to desired location for use. Refer to movement of drums information in this work package.
2. Select a dispensing site that is as level and firm as possible. Refer to Site Requirements and Layouts, WP 0006.
3. Perform During Operation Preventive Maintenance Checks and Services (PMCS). Refer to TM 10-5430-245-12&P or TM 10-5430-247-13&P.
4. Uncover one or both adapter assemblies (Figure 10, Item 1) at either end of drum by removing dust caps (Figure 10, Item 2).
5. Prior to installation, turn handwheel (Figure 10, Item 3) all the way clockwise until coupler valve (Figure 10, Item 4) is closed.

WARNING

Dirt, dust, or foreign matter may contaminate drinking water resulting in sickness or death to personnel.

6. Check coupler valve (Figure 10, Item 4) for dirt, dust or any foreign matter. Clean valve of dust, dirt or foreign matter or replace coupler valve (Figure 10, Item 4).
7. Install and lock coupler valve (Figure 10, Item 4) on adapter assembly (Figure 10, Item 1).
8. Assemble and prepare FAWPSS for use. Refer to WP 0007 for FAWPSS Model LAB 9095. Refer to WP 0008 for FAWPSS model M105.

WARNING

Check whether drum has been used with any liquid other than drinking water. Failure to check drum could lead to sickness or death to personnel. If there is any question about the quality of water, do not use water or drum.

Water from FAWPSS must be tested IAW TB MED 577 before use. Failure to comply may result in sickness or death to personnel.

9. Dispense drinking water from drum by turning handwheel (Figure 10, Item 3) counterclockwise. Increase water flow by increasing number of handwheel (Figure 10, Item 3) counterclockwise turns. Shut off or decrease water flow by turning handwheel (Figure 10, Item 3) clockwise. Refer to Operating Procedures, WP 0005.

FILLING AND MOVEMENT OF DRUMS (Contd)**DISPENSING DRINKING WATER FROM DRUM (Contd)**

10. Push down on and collapse drum (Figure 10, Item 5) as water is emptied from it; This removes maximum amount of water from drum.

END OF TASK

Figure 10. Dispensing Drinking Water.

END OF TASK

FILLING AND MOVEMENT OF DRUMS (Contd)**MOVEMENT OF DRUMS USING TOWING AND LIFTING YOKE****NOTE**

The towing and lifting yoke is not intended for use with FAWPSS Model M105 since its drums will remain tied down to a PLS Flatrack or CROP at all times. However, the towing and lifting yoke may be used with this model if necessary.

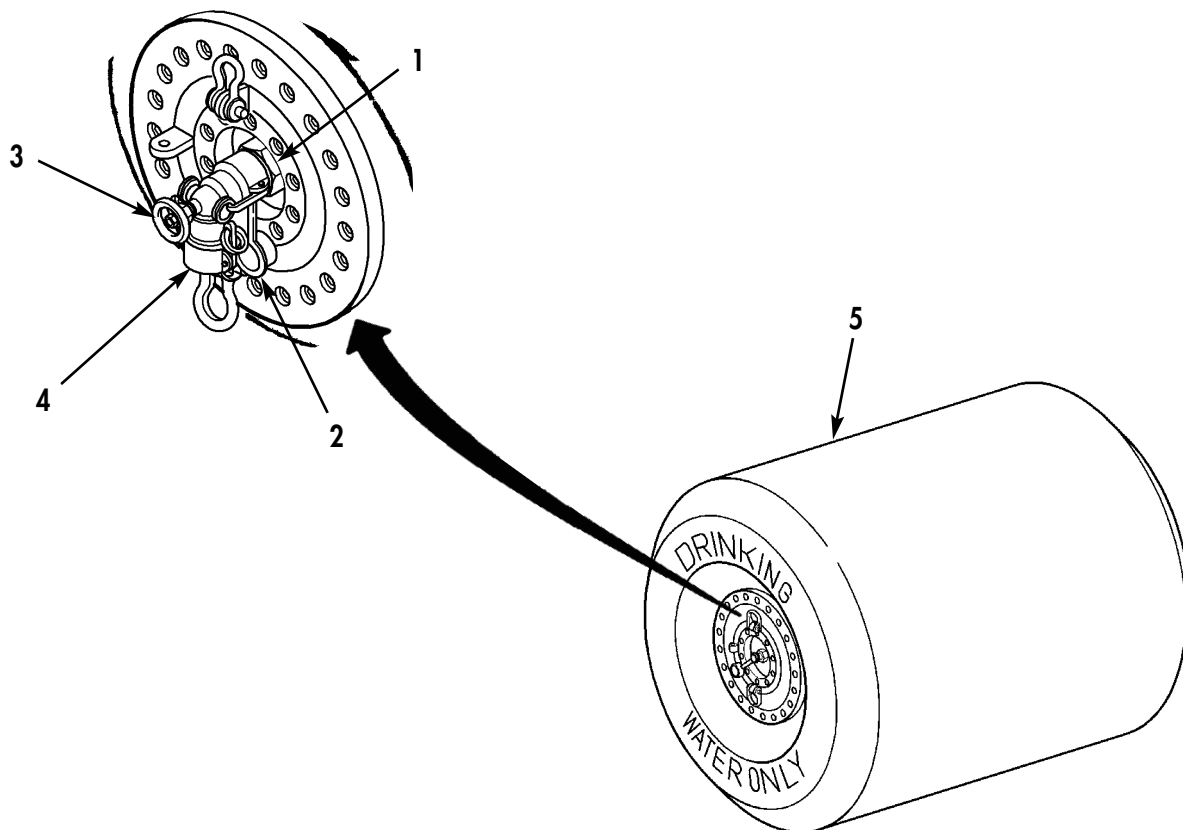
Unit maintenance will assist in assembling and connecting the towing and lifting yoke.

1. Unfold two connecting legs (Figure 11, Item 3) from two upper legs (Figure 11, Item 2).
2. Unfold two braces (Figure 11, Item 4) from two connecting legs (Figure 11, Item 3), and remove two locknuts (Figure 11, Item 5) and screws (Figure 11, Item 6) from braces (Figure 11, Item 4). Discard two locknuts (Figure 11, Item 5).
3. With holes in two braces (Figure 11, Item 4) aligned, install two screws (Figure 11, Item 6) and new locknuts (Figure 11, Item 5) on braces (Figure 11, Item 4).

WARNING

Ensure coupler valves are protected from contamination when removed from drum. Ensure plastic protective dust caps are installed on both adapter assemblies of drum to prevent contamination and damage to mating surfaces. Failure to comply may result in damage to equipment or possible injury to personnel.

CAUTION

Each drum is supplied with two coupler valves. Ensure both coupler valves are removed prior to connecting towing and lifting yoke or transporting drums. Failure to comply may result in damage to equipment.

4. Remove two coupler valves from drum. Refer to Filling Drums in this work package.
5. Connect clevis ends (Figure 11, Item 8) of towing and lifting yoke to drum (Figure 11, Item 7). Refer to WP 0004.
6. Connect towing eyes (Figure 11, Item 1) of towing and lifting yoke (Figure 11, Item 12) to pintle hook (Figure 11, Item 11) on suitable towing vehicle.

CAUTION

Sharp objects or rough terrain can cause punctures in storage drums. When towing and positioning drums on ground, ensure area is free from debris and sharp rocks or damage to equipment may result.

A filled drum may be moved a short distance at a speed not to exceed 10 mph (16 km/hr). Failure to comply may result in damage to drum.

Only full drums will be towed. If drums are not full and require movement, they must be filled prior to towing, lifted with a suitable lifting device, or emptied. Failure to comply may result in damage to equipment.

FILLING AND MOVEMENT OF DRUMS (Contd)

MOVEMENT OF DRUMS USING TOWING AND LIFTING YOKE (Contd)

7. Move and position drum (Figure 11, Item 7) according to site location and layout. Disconnect towing and lifting yoke (Figure 11, Item 12) from pintle hook (Figure 11, Item 11) on towing vehicle.
8. Remove towing and lifting yoke (Figure 11, Item 12) from drum (Figure 11, Item 7). Refer to WP 0004.
9. Remove two locknuts (Figure 11, Item 5) and screws (Figure 11, Item 6) from two braces (Figure 11, Item 4), fold both braces (Figure 11, Item 4) and connecting legs (Figure 11, Item 3), and stow two screws (Figure 11, Item 6) and locknuts (Figure 11, Item 5) on braces (Figure 11, Item 4).

NOTE

Ensure both coupler valves are closed (handwheel is turned fully clockwise to locked position) prior to connecting to drum or water will be released from drum.

Ensure gasket is present at connection between coupler valve and adapter assembly or leaking will result.

10. Carefully remove two plastic protective dust caps (Figure 11, Item 9) from adapter assemblies (Figure 11, Item 10) on drum (Figure 11, Item 7), and connect two coupler valves. Refer to TM 10-5430-245-12&P or TM 10-5430-247-13&P.

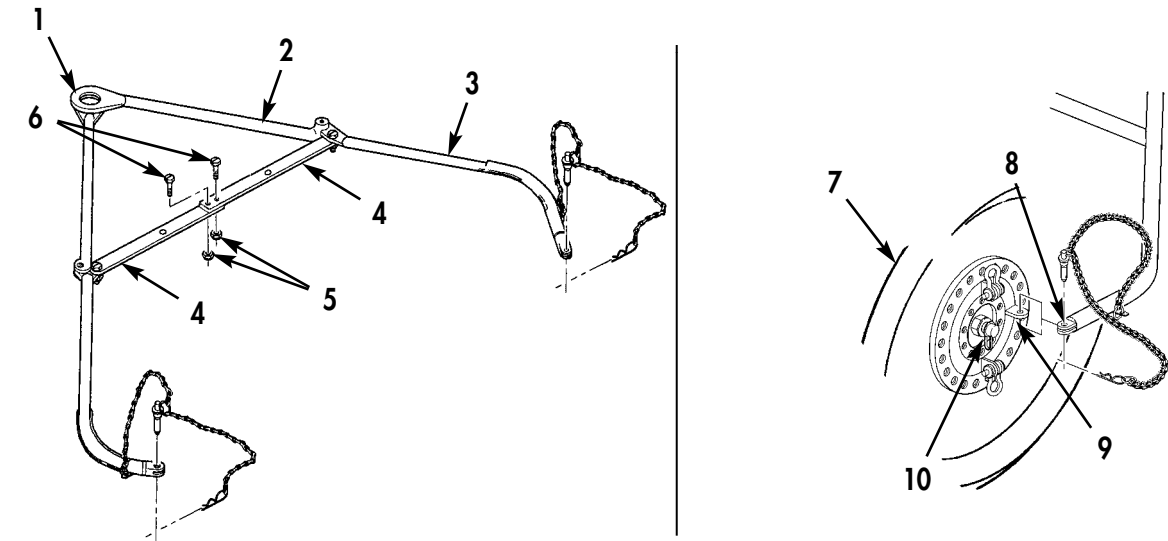

Figure 11. Use of Towing and Lifting Yoke.

END OF TASK

FILLING AND MOVEMENT OF DRUMS (Contd)

TIEDOWN OF DRUMS AND CRATE ON PLS FLATRACK OR CROP — MODEL M105

1. Tiedown of Drums

NOTE

The following procedure contains specific instructions for securing three 500 GAL drums and one shipping crate containing FAWPSS equipment to either a PLS Flatrack or CROP.

- a. Perform PMCS on drums prior to securing them to PLS flatrack or CROP. Refer to TM 10-5430-245-12&P or TM 10-5430-247-13&P for Model M105.

WARNING

Always wear gloves to protect hands when handling tiedown chain assemblies and tiedown straps. Failure to comply may result in injury to personnel.

- b. Perform PMCS on tiedown kit. Ensure there are twelve chain tiedown assemblies (Figure 12, Item 1), ten tiedown straps (Figure 12, Item 2), and sixteen protective nylon sleeves (Figure 12, Item 3). Refer to WP 0016.
- c. Check platform surface (Figure 13, Item 6) of PLS Flatrack or CROP for debris or sharp edges that may damage drums. Notify unit maintenance to remove sharp edges as necessary.

WARNING

Do not attempt to position, fill, or tiedown drums with PLS Flatrack or CROP loaded on truck. Failure to comply may result in damage to equipment or injury to personnel.

- d. Unload PLS Flatrack or CROP to ground. Refer to TM 9-3990-206-14&P for PLS Flatrack, and TM 9-3990-260-14&P for CROP.

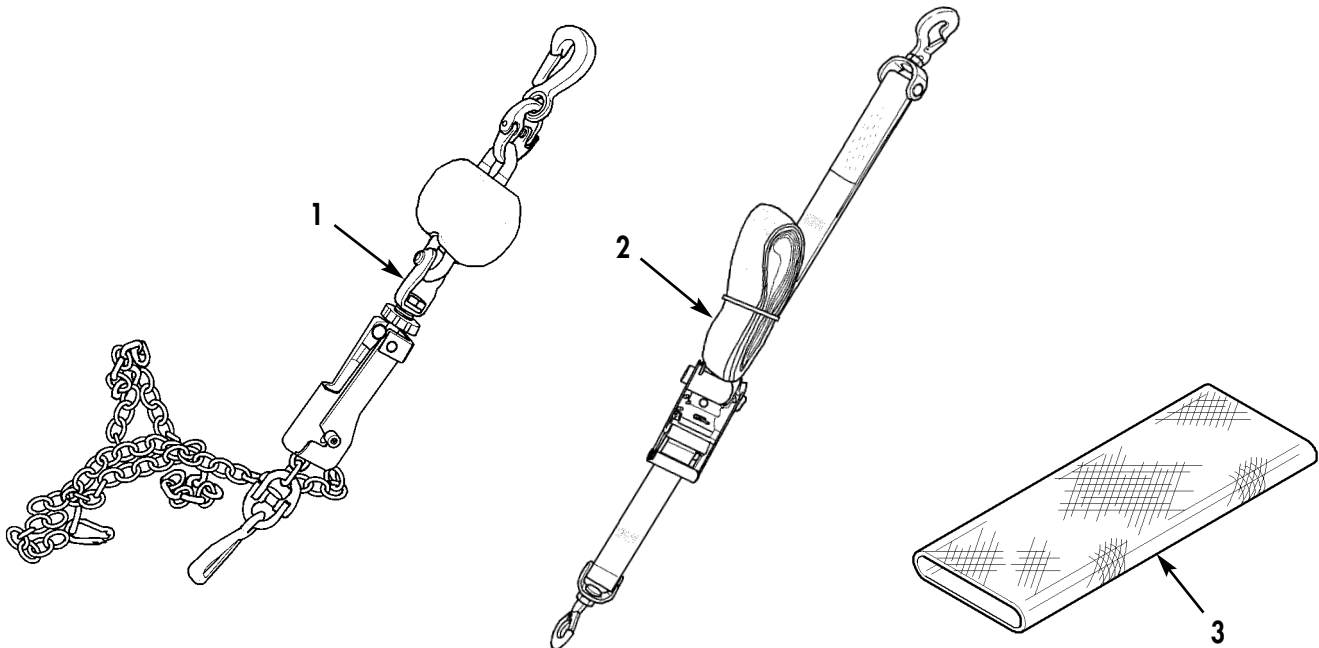

Figure 12. Drum Tiedown Kit.

FILLING AND MOVEMENT OF DRUMS (Contd)

TIEDOWN OF DRUMS AND CRATE ON PLS FLATRACK OR CROP — MODEL M105 (Contd)

WARNING

All personnel must stand clear of equipment during lifting operations or serious injury or death to personnel may result.

CAUTION

If filled drums will be loaded or repositioned on PLS Flatrack or CROP with a forklift, ensure forklift has a minimum lifting capacity of 5,000 lb (2,268 kg). Drums may only be lifted from bow shackles at both ends of drum using suitable lifting straps or chains secured to forks from above. Do not attempt to lift drums by placing forks at bottom of drum. Failure to comply will result in damage to equipment.

NOTE

Installation and tiedown of drums on PLS Flatrack or CROP is basically the same. CROP is shown.

Drums should be positioned on CROP empty; two assistants will help lift and position each drum.

When filling empty drums on CROP, unfolding and repositioning by hand is necessary to ensure each drum will line up evenly within 2 in. (51 mm) of platform centerline when full. Repositioning after filling cannot be performed without a suitable lifting device.

- e. Position front drum (Figure 13, Item 3) next to CROP A-frame (Figure 13, Item 2) approximately 12 in. (30 cm) from either side edge (Figure 13, Item 5) of CROP platform (Figure 13, Item 6). If empty, fill drum (Figure 13, Item 3). Refer to Filling Drums in this work package.
- f. Position center drum (Figure 13, Item 4) directly behind first drum (Figure 13, Item 3) approximately 12 in. (30 cm) from either side edge (Figure 13, Item 5) of CROP platform (Figure 13, Item 6). If empty, fill drum (Figure 13, Item 4).
- g. Position rear drum (Figure 13, Item 1) directly behind center drum (Figure 13, Item 4) approximately 12 in. (30 cm) from either side edge (Figure 13, Item 5) of CROP platform (Figure 13, Item 6). If empty, fill drum (Figure 13, Item 1).

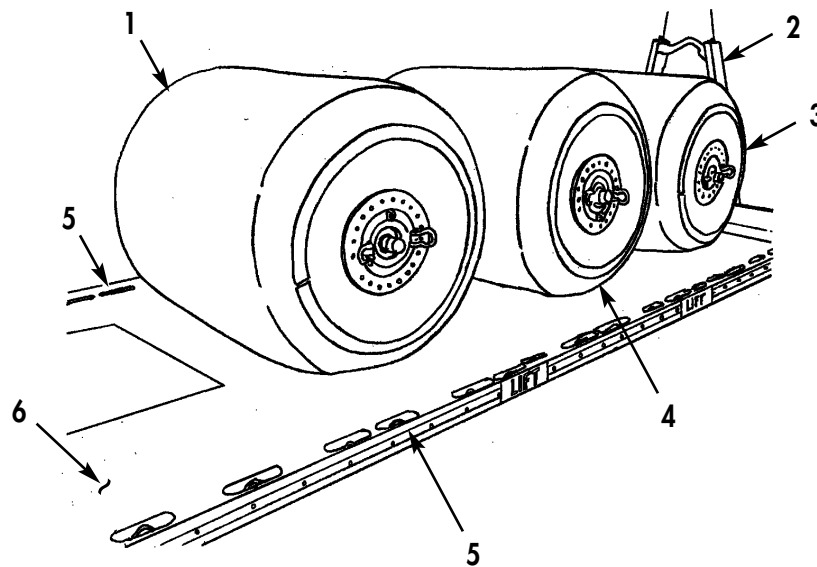

Figure 13. Drums Positioned on CROP.

FILLING AND MOVEMENT OF DRUMS (Contd)

TIEDOWN OF DRUMS AND CRATE ON PLS FLATRACK OR CROP — MODEL M105 (Contd)

WARNING

Only the chain tiedown assemblies from the FAWPSS tiedown kit will be used to secure drums. Failure to comply may result in damage to equipment or injury to personnel.

- h. Adjust length of twelve chain tiedown assemblies by rotating adjustment wheel (Figure 14, Item 14) of tensioner (Figure 14, Item 8) out to mid-point of threaded shaft (Figure 14, Item 13).

WARNING

Do not crisscross chain tiedown straps or drums will become loose during movement. Failure to comply may result in damage to equipment or possible injury to personnel.

NOTE

Installation of tiedown chain assemblies is performed with filled drums. Ensure all chain hooks are connected facing in.

CROP and PLS Flatrack tiedown rings are numbered sequentially from front to rear. Refer to table 1, Platform Tiedown Rings, when locating chain assembly hooks to tiedown rings.

- i. Connect tensioner assembly hook (Figure 14, Item 7) to front bow shackle (Figure 14, Item 3) on front drum (Figure 14, Item 1), and connect chain assembly hook (Figure 14, Item 10) to #1 tiedown ring (Figure 14, Item 4) at both sides of CROP (Figure 14, Item 6).

Table 1. Platform Tiedown Rings.

DRUM #	DRUM SHACKLE	CROP RING #	PLS FLATRACK RING #
1 (Front)	Front	1	1
	Rear	6	4
2 (Center)	Front	5	3
	Rear	13	7
3 (Rear)	Front	11	6
	Rear	19	10

WARNING

Ensure all non-essential personnel are clear of drums when positioning them during tiedown. Failure to comply may result in injury to personnel.

NOTE

Drums may be rolled toward front or rear of CROP for positioning during installation of tiedown chain assemblies. Two assistants will help as necessary.

Steps j and k establish position of front drum on platform.

FILLING AND MOVEMENT OF DRUMS (Contd)

TIEDOWN OF DRUMS AND CRATE ON PLS FLATRACK OR CROP — MODEL M105 (Contd)

- j. Open tensioner handle (Figure 14, Item 12), pass chain assembly (Figure 14, Item 9) through center of tensioner (Figure 14, Item 8) until third link from hook (Figure 14, Item 11) can be placed in slot on tensioner (Figure 14, Item 8) at both ends of front drum (Figure 14, Item 1).

NOTE

Ensure platform tiedown rings are fully extended before tension is applied.

- k. Lock tensioner (Figure 14, Item 8) at both sides of front drum (Figure 14, Item 1). Refer to WP 0004.
- l. With bow shackle (Figure 14, Item 2) approximately horizontal to platform, connect tensioner assembly hook (Figure 14, Item 7) to bow shackle (Figure 14, Item 2) on front drum (Figure 14, Item 1), and connect chain assembly hook (Figure 14, Item 10) to # 6 tiedown ring (Figure 14, Item 5) at both sides of CROP (Figure 14, Item 6).
- m. Open tensioner handle (Figure 14, Item 12), pass chain assembly (Figure 14, Item 9) through center of tensioner (Figure 14, Item 8) as far as possible, then place link in slot on tensioner (Figure 14, Item 8) at both sides of front drum (Figure 14, Item 1).

NOTE

If unable to close tensioner handle until locked, loosen chain one link at a time until tensioner can be locked.

- n. Lock tensioner (Figure 14, Item 8) at both sides of front drum (Figure 14, Item 1). Refer to WP 0004.

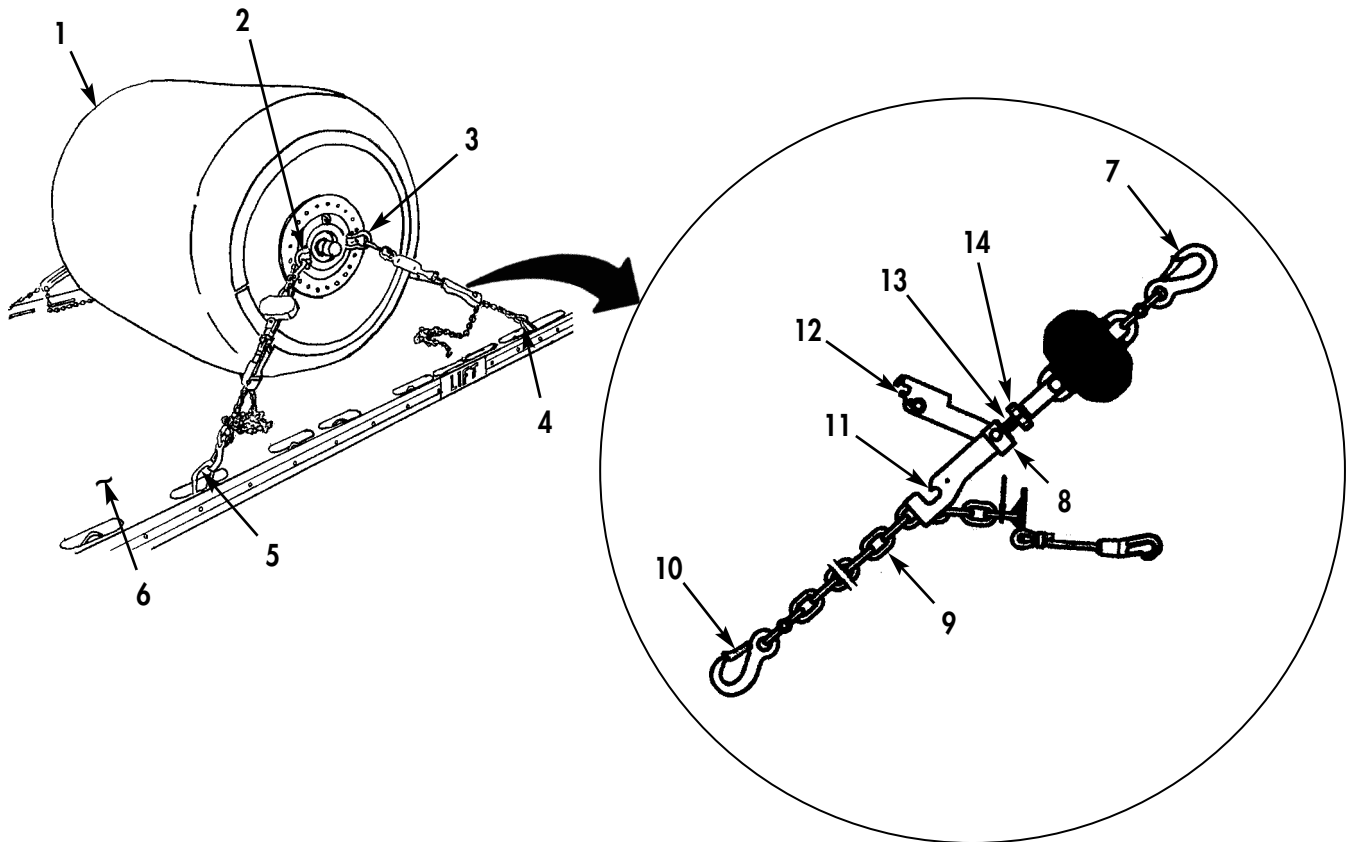

Figure 14. Tiedown Chains Installation.

FILLING AND MOVEMENT OF DRUMS (Contd)

TIEDOWN OF DRUMS AND CRATE ON PLS FLATRACK OR CROP — MODEL M105 (Contd)

NOTE

Ensure drum bow shackles remain approximately horizontal when adjusting tension of chain tiedown assemblies. If bow shackles are not horizontal after tensioning, adjust opposite tiedowns alternately.

Tension will be applied diagonally following tension order. This ensures drum is not tilted to one side resulting in uneven weight distribution. Refer to figure 15 when tensioning drums.

- o. Check tightness of all four chain tiedown assemblies on first drum (Figure 16, Item 3) by checking handwheel (Figure 15, Item 1) on each tensioner assembly (Figure 15, Item 3) for looseness. If handwheel (Figure 15, Item 1) can be turned by hand, open tensioner handle (Figure 15, Item 6), take up slack chain link at hook (Figure 15, Item 5), and close and lock tensioner handle (Figure 15, Item 6). Repeat until handwheel (Figure 15, Item 1) on each tensioner (Figure 15, Item 3) cannot be turned by hand.

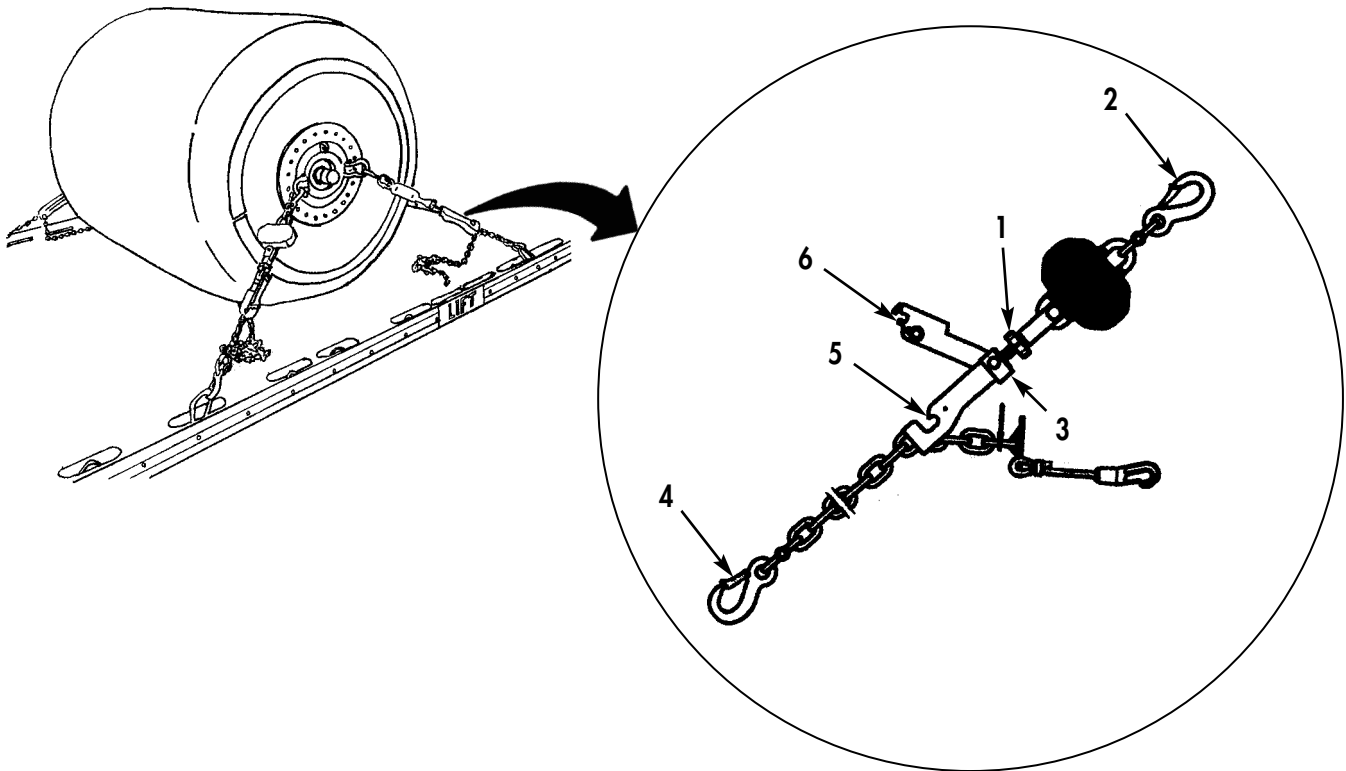

Figure 15. Tensioning Tiedowns.

- p. Roll center drum (Figure 16, Item 2) forward until in contact with front drum (Figure 16, Item 3).
- q. Connect tensioner assembly hook (Figure 15, Item 2) to bow shackle (Figure 16, Item 4) on center drum (Figure 16, Item 2), and connect chain assembly hook (Figure 15, Item 4) to platform tiedown ring listed in table 1 at both sides of CROP (Figure 16, Item 6).
- r. With bow shackle (Figure 16, Item 5) approximately horizontal to platform, connect tensioner assembly hook (Figure 15, Item 2) to bow shackle (Figure 16, Item 5) on center drum (Figure 16, Item 2), and connect chain assembly hook (Figure 15, Item 4) to platform tiedown ring listed in table 1 at both sides of CROP (Figure 16, Item 6).

FILLING AND MOVEMENT OF DRUMS (Contd)

TIEDOWN OF DRUMS AND CRATE ON PLS FLATRACK OR CROP — MODEL M105 (Contd)

NOTE

Tightening chain tiedown assemblies should pull center drum about 1 in. (25 mm) clear from contact with front drum.

- s. Repeat steps m through o to tension chain tiedown assemblies on center drum (Figure 16, Item 2).
- t. Repeat steps p through s for rear drum (Figure 16, Item 1).

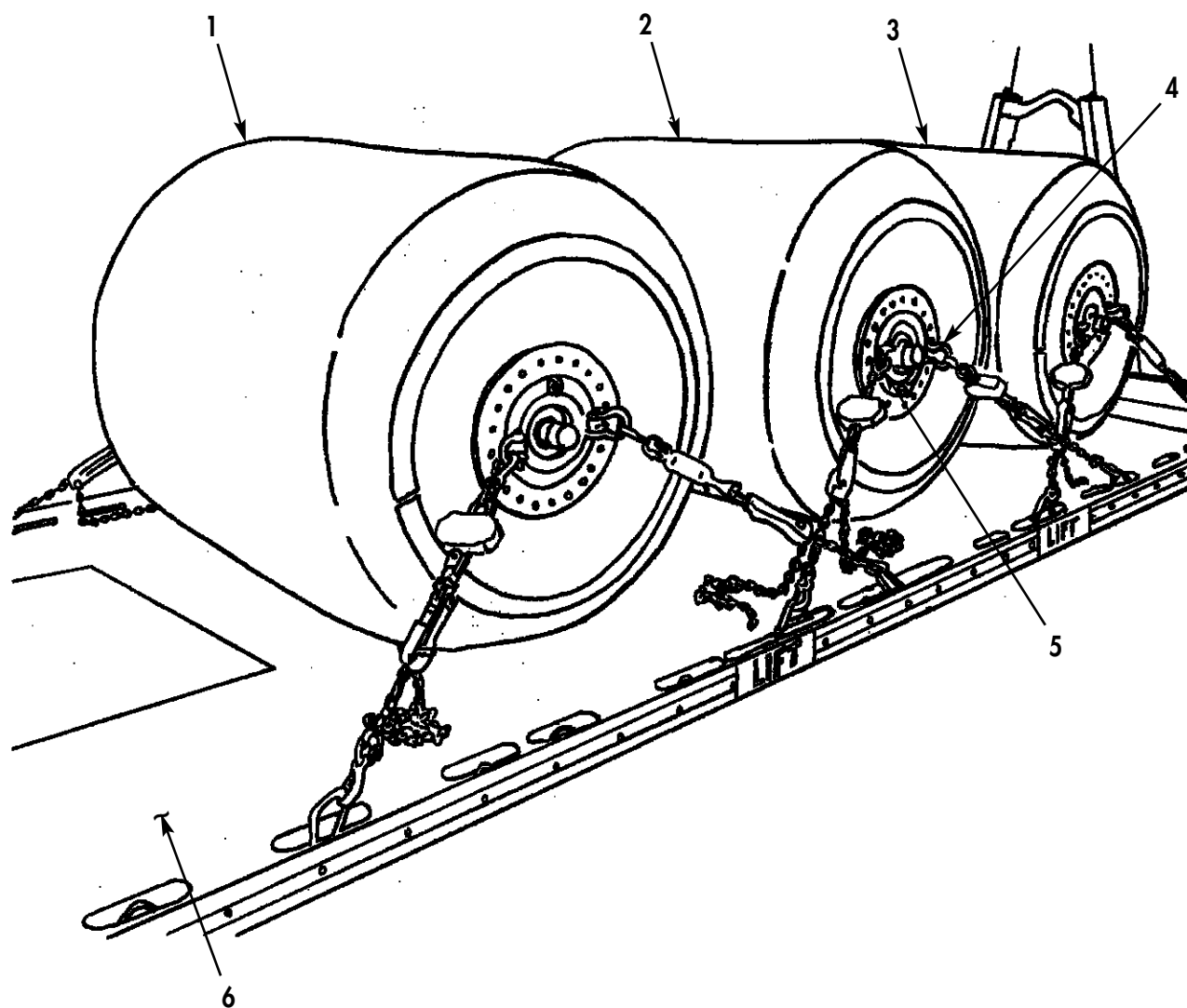

Figure 16. Tiedown Chains Installed.

FILLING AND MOVEMENT OF DRUMS (Contd)

TIEDOWN OF DRUMS AND CRATE ON PLS FLATRACK OR CROP — MODEL M105 (Contd)

2. Tiedown of Shipping Crate
 - a. Ensure crate (Figure 17, Item 2) is properly closed and latched. Refer to WP 0018.
 - b. Using suitable lifting device or forklift, position shipping crate (Figure 17, Item 1) on CROP (Figure 17, Item 11) so that it is 3 in. (76 mm) from rear flaps (Figure 17, Item 6) and within 2 in. (51 mm) of platform centerline.
 - c. Position two protective sleeves (Figure 17, Item 3) on each of two tiedown straps (Figure 17, Item 4), and position two tiedown straps (Figure 17, Item 4) over top of crate (Figure 17, Item 2).
 - d. Connect hook ends (Figure 17, Item 10) of two straps (Figure 17, Item 4) to platform tiedown rings (Figure 17, Item 9) at both sides of CROP (Figure 17, Item 11), loosely tighten straps (Figure 17, Item 4), and position four protective sleeves (Figure 17, Item 3) on edges at top of crate (Figure 17, Item 2).
 - e. Position four protective sleeves (Figure 17, Item 1) on each of two tiedown straps (Figure 17, Item 5), and position two tiedown straps (Figure 17, Item 5) by crisscrossing them over top of crate (Figure 17, Item 2).
 - f. Connect hook ends (Figure 17, Item 8) of two straps (Figure 17, Item 5) to platform tiedown rings (Figure 17, Item 7) at both sides of CROP (Figure 17, Item 11), loosely tighten straps (Figure 17, Item 5), and position eight protective sleeves (Figure 17, Item 1) on edges at top and sides of crate (Figure 17, Item 2).
 - g. Evenly tight two tiedown straps (Figure 17, Item 4) and (Figure 17, Item 5). Refer to WP 0004.

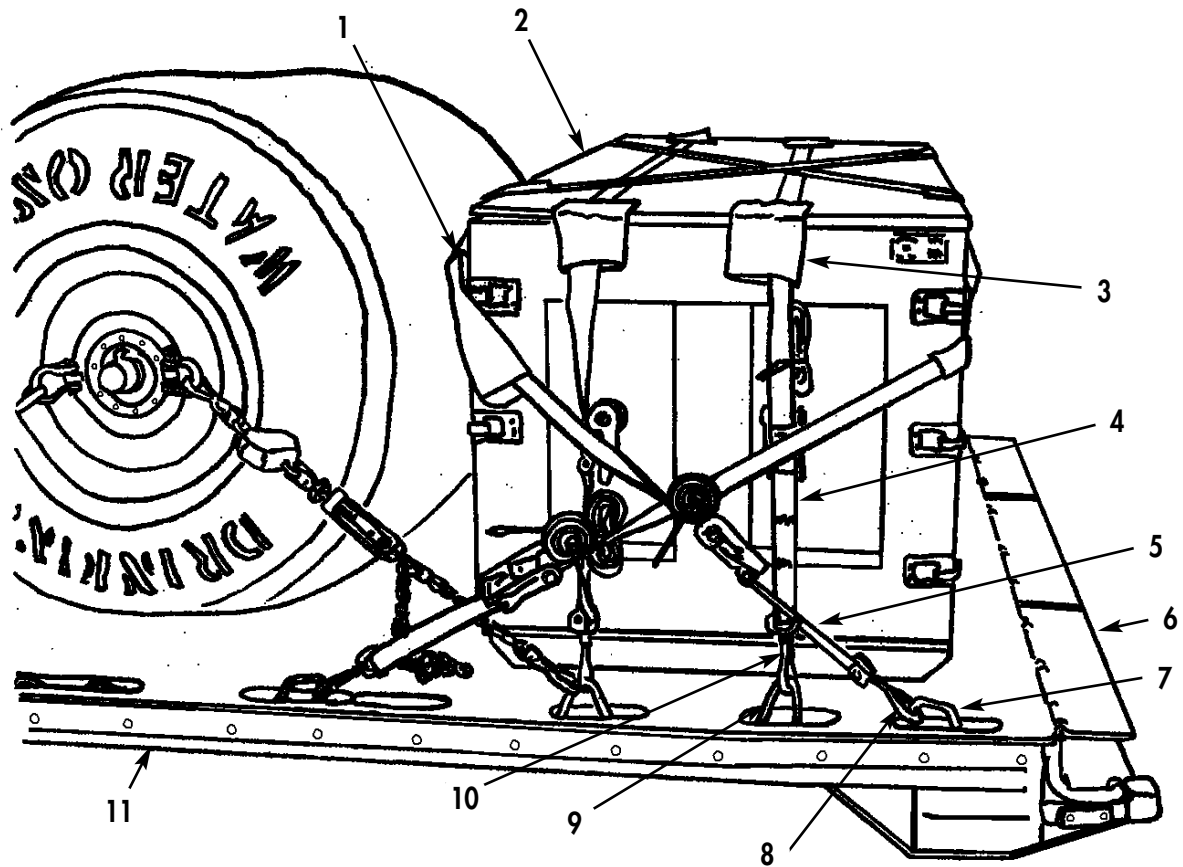

Figure 17. Tiedown of Shipping Crate.

END OF TASK

FILLING AND MOVEMENT OF DRUMS (Contd)**MOVEMENT OF FULL, PARTIALLY FULL, OR EMPTY DRUMS ON PLS FLATRACK OR CROP — MODEL M105**

1. Movement of Full Drums

- a. Transport load on PLS Flatrack or CROP IAW TM 9-3990-206-14&P for PLS Flatrack, and TM 9-3990-260-14&P for CROP.

WARNING

Unless adjustment of tiedowns can be performed by operator while standing on ground, unload platform to ground prior to tightening tiedowns to prevent possible falls from elevated platform. Failure to comply may result in injury to personnel.

Always wear gloves to protect hands when handling tiedown chain assemblies and tiedown straps. Failure to comply may result in injury to personnel.

Drums weigh up to 4,300 lb (1,952 kg). Use caution when removing chain tiedown assemblies or injury to personnel may result.

All personnel must stand clear of equipment during lifting operations or serious injury or death to personnel may result.

CAUTION

Drums will stretch during transport, storage, and temperature changes resulting in loose tiedowns. Ensure all tiedowns on drums and crate are checked as required or damage to equipment may result.

After first hour of transport and every two hours thereafter, check load for shifting and loose tiedown assemblies on all drums and crate. Tighten tiedowns wherever slack is found. Refer to tensioning procedures in this work package.

2. Movement of Partially Full or Empty Drums

WARNING

A partially full drum will allow motion of water due to forces resulting from transport. Never transport with more than one partially filled drum. Ensure remaining two drums are either full or as empty as they can be pumped out. Failure to comply may result in damage to equipment or possible injury to personnel.

NOTE

A partially full drum will be secured by tightening chain tiedown assemblies first and two crisscrossed tiedown straps second. An empty drum will be secured with two tiedown straps.

Perform steps a through f prior to loading platform on truck.

FILLING AND MOVEMENT OF DRUMS (Contd)**MOVEMENT OF FULL, PARTIALLY FULL, OR EMPTY DRUMS ON PLS FLATRACK OR CROP — MODEL M105 (Contd)**

- a. Position two tiedown straps (Figure 18, Item 6) crisscrossed on top of each partially full or empty drum.

CAUTION

Ensure drum end plates are folded down prior to connecting and tightening tiedown straps on any empty drum. Failure to comply will result in damage to equipment.

Ensure ratchets on tiedown straps are facing out and are not in contact with drum so as to pinch or cause wear to surface of drum. Failure to comply may result in damage to equipment.

- b. Connect hook ends (Figure 18, Item 3) of two straps (Figure 18, Item 6) to platform tiedown rings (Figure 18, Item 4) at both sides of CROP, and loosely tighten straps (Figure 18, Item 6). Refer to WP 0004.

NOTE

As drum drains, adjust chain tiedown assemblies and tiedown straps to allow end plates to fold inward.

- c. If two or more drums are partially full, completely drain all but one partially full drum starting sequentially from rear of platform forward. Drain drum using pump unit. Refer to TM 5-4320-368-14&P for pump unit operation.

CAUTION

Do not transport a partially full drum with bottom edge of drum plates within 3 in. (76 mm) of platform. Failure to comply may result in damage to drum.

NOTE

Perform step d to secure partially full drum. Perform steps e and f to secure emptied drums.

On forward drum, it may be necessary to move the rearward chain assembly back one platform ring on both sides of CROP due to insufficient range of adjustment.

- d. Tighten two chain tiedown assemblies (Figure 18, Item 2) on each side of drum (Figure 18, Item 1) following tension order shown in figure 18, then tighten two tiedown straps (Figure 18, Item 6) in same manner. Roll up ends of tiedown straps (Figure 18, Item 6) and secure with ties as necessary.
- e. Loosen two chain tiedown assemblies (Figure 18, Item 2) on both sides of empty drum (Figure 18, Item 1) to allow end plates (Figure 18, Item 5) to fold inward when tightening tiedown straps (Figure 18, Item 6).
- f. Alternately tight two tiedown straps (Figure 18, Item 6) on empty drum (Figure 18, Item 1). Roll up ends of tiedown straps (Figure 18, Item 6) and secure with ties as necessary.

FILLING AND MOVEMENT OF DRUMS (Contd)

MOVEMENT OF FULL, PARTIALLY FULL, OR EMPTY DRUMS ON PLS FLATRACK OR CROP — MODEL M105 (Contd)

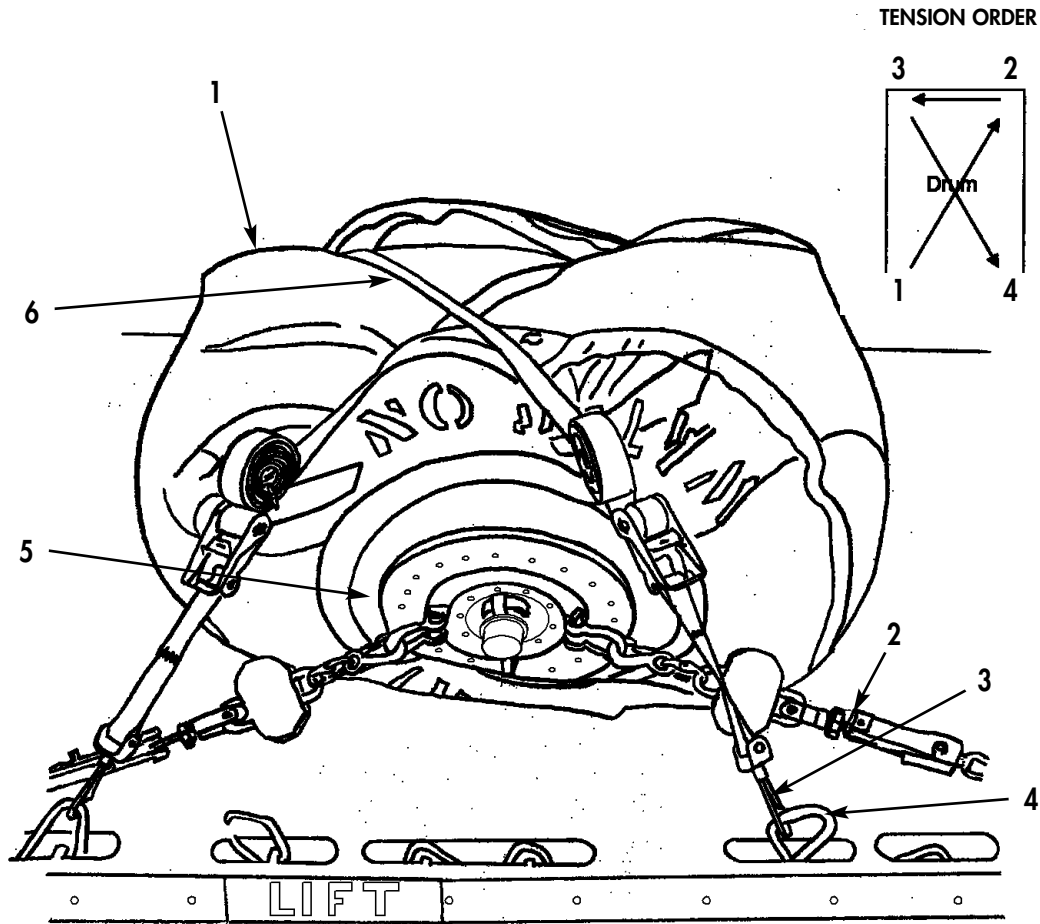

Figure 18. Tiedown Straps Installed on Drum.

END OF TASK

MOVEMENT OF DRUMS BY HELICOPTER

The NCOIC will coordinate movement of drums with helicopter crew. Refer to TM 746-10 and TM 55-2200-001-12.

END OF TASK

USE OF DRUM REPAIR KIT

NOTE

Each drum supplied with FAWPSS Model M105 includes a drum body repair kit. This kit is provided for making temporary repairs only, and it may also be used on drums supplied with FAWPSS Model LAB 9095.

This procedure covers temporary repair of the drum body only, and it is limited to plugging punctures 3/8 in. (9.5 mm) in diameter or less. After temporary repair of drum body, the drum will only be used until emptied after which unit maintenance will be notified.

FILLING AND MOVEMENT OF DRUMS (Contd)**USE OF DRUM REPAIR KIT (Contd)**

1. Push tapered (pointed) end of wood plug (Figure 19, Item 1) into hole (Figure 19, Item 2) until snug.
2. Roll drum (Figure 19, Item 3) over so plugged hole (Figure 19, Item 4) is facing up.

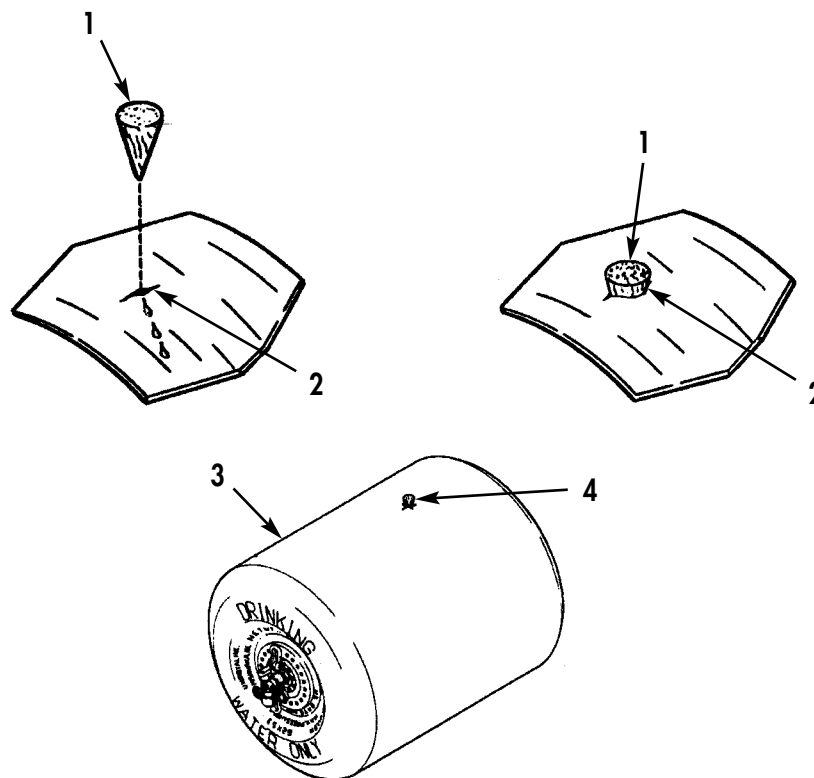

Figure 19. Wood Plug Installation.

3. To seal puncture until permanent repair can be performed, install plug assembly (Figure 20, Item 3) as follows:

WARNING

Use the protective hood supplied with drum kit to protect eyes and face prior to installing a plug assembly. Failure to comply may result in injury to personnel.

FILLING AND MOVEMENT OF DRUMS (Contd)

USE OF DRUM REPAIR KIT (Contd)

- a. Using rotary cutter supplied with drum repair kit, cut clean edge around puncture hole (Figure 20, Item 2) in drum body (Figure 20, Item 1).
- b. Install plug assembly (Figure 20, Item 3) on drum body (Figure 20, Item 1) by pushing rounded end of plug assembly (Figure 20, Item 3) through puncture hole (Figure 20, Item 2).
- c. Pull plug assembly (Figure 20, Item 3) so that rounded end is tight against inside surface of drum body (Figure 20, Item 1), and tighten nut (Figure 20, Item 4) until washer (Figure 20, Item 5) is snug.
- d. Using pliers supplied with drum kit, turn nut (Figure 20, Item 4) until tight, then cut off excess shank (Figure 20, Item 6) even with top of nut (Figure 20, Item 4).

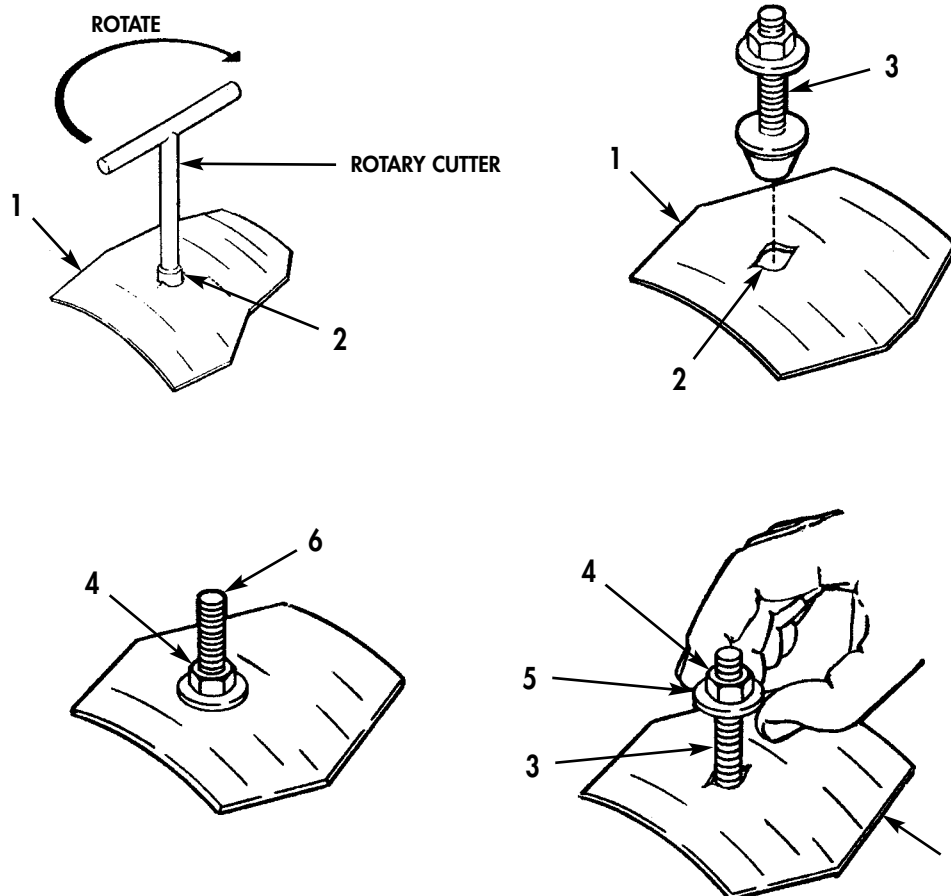

Figure 20. Plug Assembly Installation.

END OF TASK

END OF WORK PACKAGE

OPERATOR INSTRUCTIONS
FORWARD AREA WATER POINT SUPPLY SYSTEM (FAWPSS)
DISASSEMBLY FOR MOVEMENT — MODEL LAB 9095
EFFECTIVE NOTICE
 Model LAB 9095

INITIAL SETUP

Materials/Parts

Shipping crates (WP 0050)

Equipment Condition

FAWPSS assembled for use (WP 0007).

WARNING

A partially full drum will allow motion of water due to forces resulting from transport. Never transport with more than one partially filled drum. Ensure remaining two drums are either full or as empty as they can be pumped out. Failure to comply may result in damage to equipment or possible injury to personnel.

NOTE

This work package covers disassembly after use of FAWPSS Model LAB 9095 as required prior to transport of equipment. Drums will be moved IAW WP 0009.

Ball valves are opened in step 1 to allow residual water to drain when disconnecting hoses.

1. Close coupler valves (Figure 1, Item 1) on two drums (Figure 1, Item 3), and open two ball valves (Figure 1, Item 4). Refer to WP 0004.
2. Drain pump by removing drain plug. Refer to WP 0004.

CAUTION

Ensure dust cap or plug is installed on open end of each coupling immediately after disconnecting. When disconnecting hoses and fittings, ensure a gasket is present prior to installing dust cap or plug. Failure to comply may result in contamination, loss of gasket, or damage to mating surfaces.

3. Disconnect 2 in. (51 mm) DIA x 10 ft (3 m) long suction hose assembly (Figure 1, Item 2) from coupler valve (Figure 1, Item 1) on two drums (Figure 1, Item 3), and install dust cap on coupling end of each hose assembly (Figure 1, Item 2).

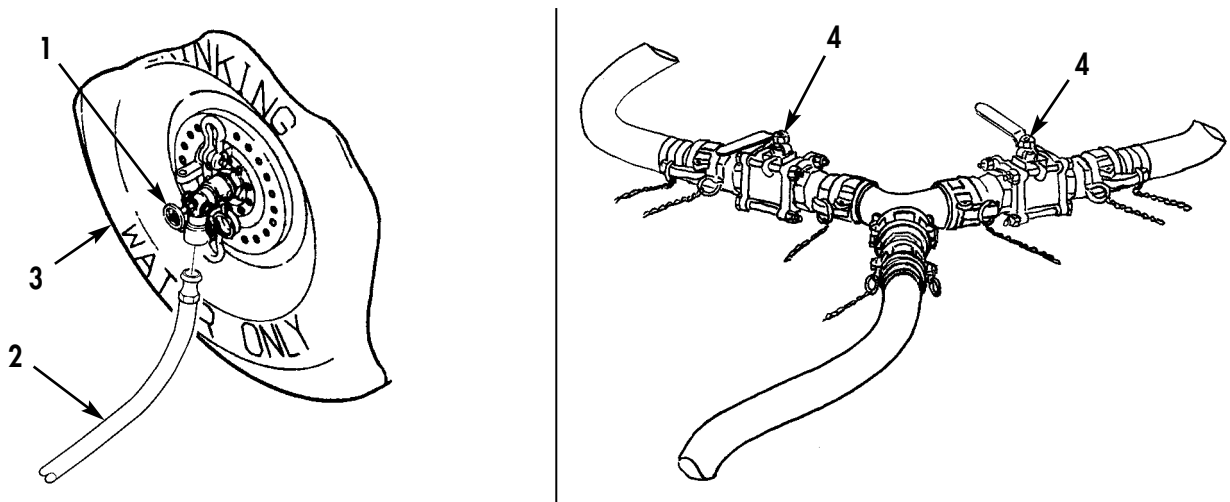

Figure 1. Coupler Valves and Ball Valves.

DISASSEMBLY FOR MOVEMENT— MODEL LAB 9095 (Contd)

4. Remove two 2 in. (51 mm) DIA x 10 ft (3 m) long suction hose assemblies (Figure 2, Item 1) from two ball valves (Figure 2, Item 2). Drain water and install plug on coupling end of each hose assembly (Figure 2, Item 1).
5. Remove two ball valves (Figure 2, Item 2) from Y-fitting (Figure 2, Item 3), and install cap and plug on each ball valve (Figure 2, Item 2).
6. Remove two Y-fittings (Figure 2, Item 3) and male adapter (Figure 2, Item 5) from 2 in. (51 mm) DIA x 10 ft (3 m) long suction hose assembly (Figure 2, Item 4). Install caps and plugs.
7. Remove 2 in. (51 mm) DIA x 10 ft (3 m) long suction hose assembly (Figure 3, Item 4) from female quick-disconnect coupling (Figure 3, Item 10) on pump suction port (Figure 3, Item 9). Drain water from hose assembly (Figure 3, Item 4) and install cap and plug.
8. Disconnect 2 in. (51 mm) DIA x 10 ft (3 m) long discharge hose assembly (Figure 3, Item 8) from male quick-disconnect coupling (Figure 3, Item 7) on pump discharge port (Figure 3, Item 6). Install cap and plug.

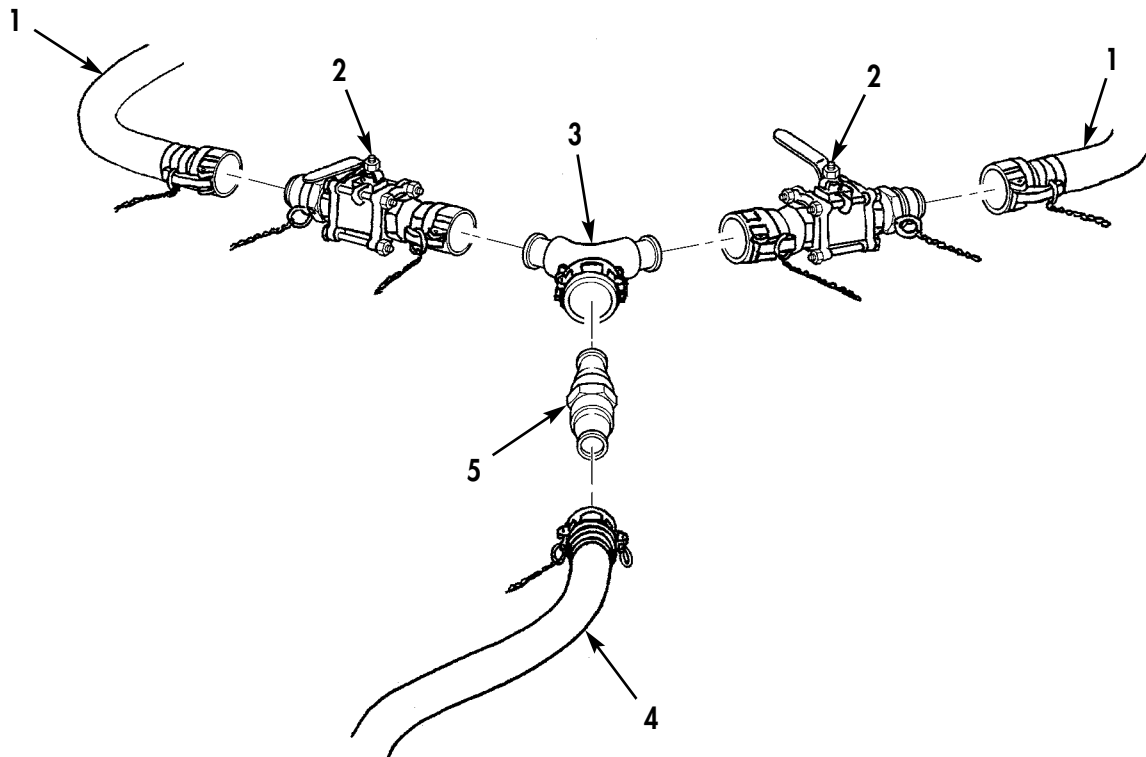

Figure 2. Disconnecting Hoses.

DISASSEMBLY FOR MOVEMENT— MODEL LAB 9095 (Contd)

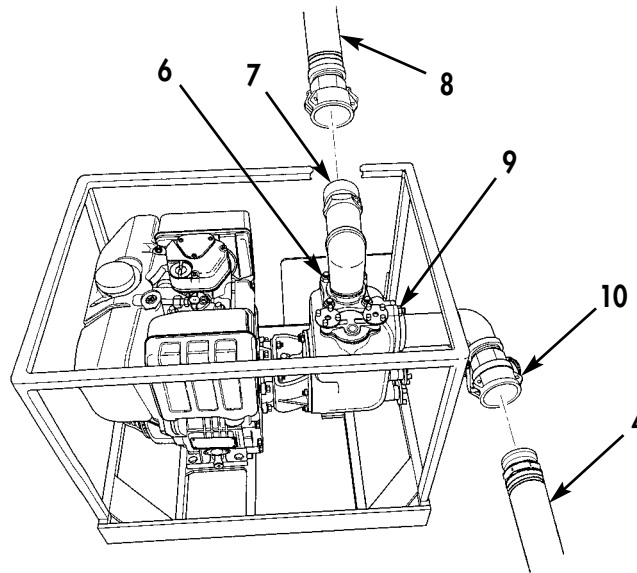

Figure 3. Disconnecting Pump.

9. Remove 2 in. (51 mm) DIA x 10 ft (3 m) long discharge hose assemblies (Figure 4, Item 8) from Y-fitting (Figure 4, Item 12). Drain water from hose and install cap.
10. Disconnect two 2 in. (51 mm) DIA x 25 ft (7.6 m) long discharge hose assemblies (Figure 4, Item 11) from Y-fitting (Figure 4, Item 12).

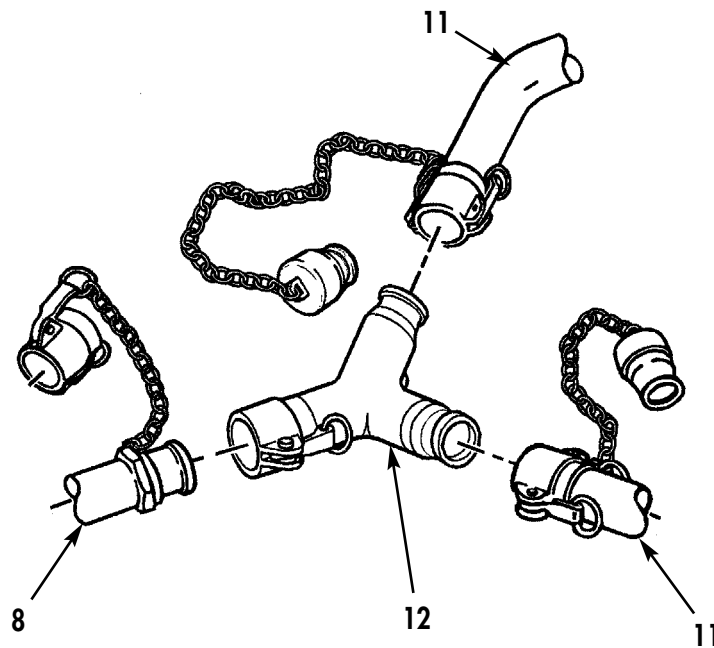

Figure 4. Disconnecting from Y-Fitting.

DISASSEMBLY FOR MOVEMENT— MODEL LAB 9095 (Contd)

11. Remove two 2 in. (51 mm) DIA x 25 ft (7.6 m) long discharge hose assemblies (Figure 5, Item 1) from two Y-fittings (Figure 5, Item 2). Lift each hose assembly (Figure 5, Item 1) over shoulder and walk hose line to drain water, then install caps and plugs on two hose assemblies (Figure 5, Item 1).

WARNING

To prevent contamination, leave nozzles hooked to stands when disconnecting hoses. Contamination may result in illness to personnel.

12. Remove four 1.5 in. (38 mm) DIA x 25 ft (7.6 m) long discharge hose assemblies (Figure 5, Item 3) from four reducers (Figure 5, Item 4) and four nozzle assemblies (Figure 5, Item 5). Lift each hose assembly (Figure 5, Item 3) over shoulder and walk hose line to drain water, then install caps and plugs on four hose assemblies (Figure 5, Item 3).
13. Remove four reducers (Figure 5, Item 4) from two Y-fittings (Figure 5, Item 2).

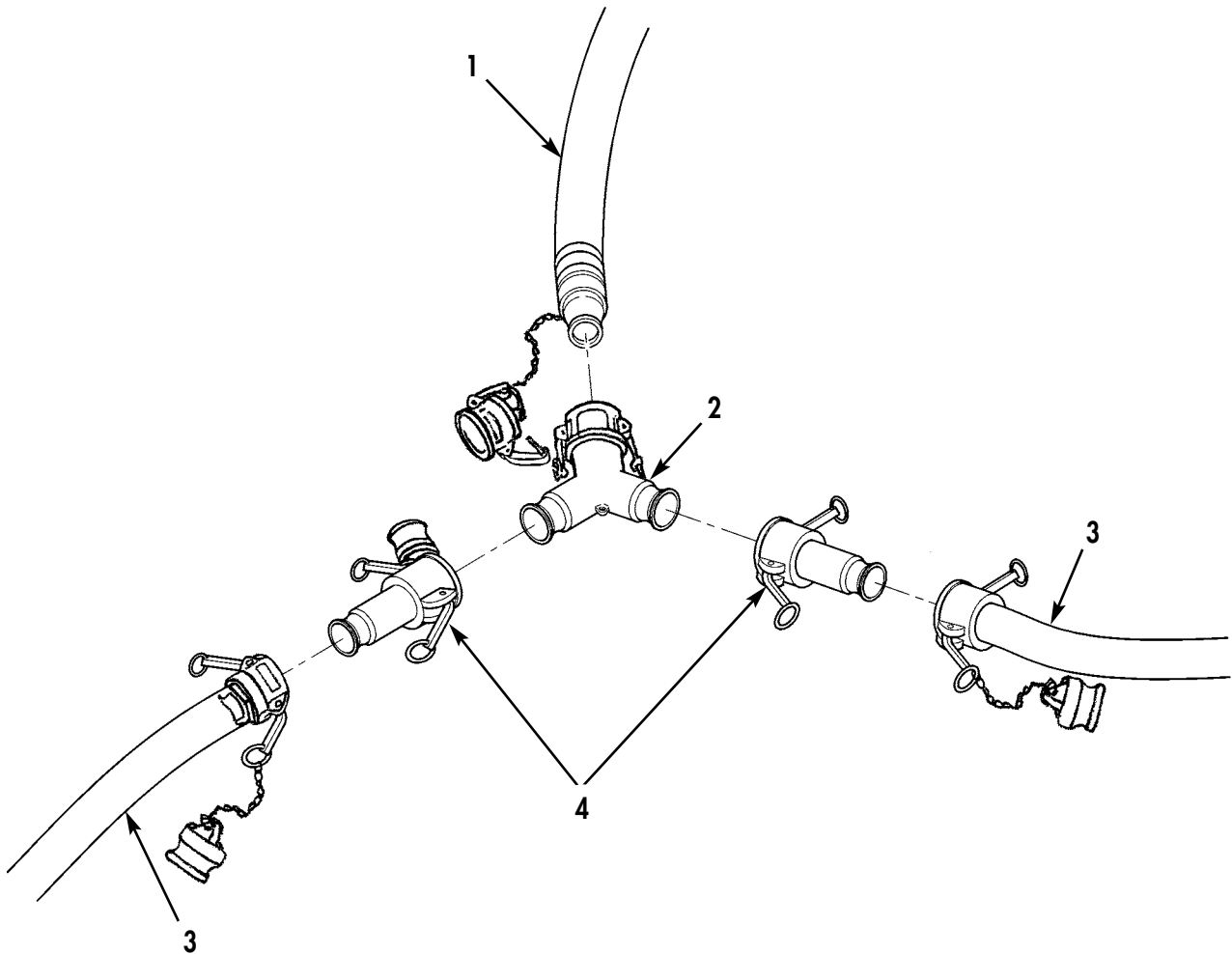

Figure 5. Disconnecting Hoses from Nozzles.

DISASSEMBLY FOR MOVEMENT— MODEL LAB 9095 (Contd)

14. Install plug (Figure 6, Item 6) on each nozzle coupling (Figure 6, Item 7), and remove four nozzle assemblies (Figure 6, Item 5) from two nozzle stands (Figure 6, Item 8).
15. Fold two nozzle stand assemblies (Figure 6, Item 3). Refer to WP 0004.
16. Remove coupler valves from drums, and install plastic protective caps on adapter assemblies of drums. Refer to WP 0018.

CAUTION

Ensure FAWPSS equipment is packed in original shipping crates or suitable containers for transportation. Failure to comply may result in damage to equipment.

NOTE

The equipment crate provided for FAWPSS Model LAB 9095 contains a complete system minus the pump unit and drums. The pump and drums are packaged in separate crates. Refer to WP 0050 for shipping crate dimensions.

17. Pack all hose assemblies, valves, fittings, nozzle stands, pump unit, and drums in their respective crates. Refer to WP 0018.

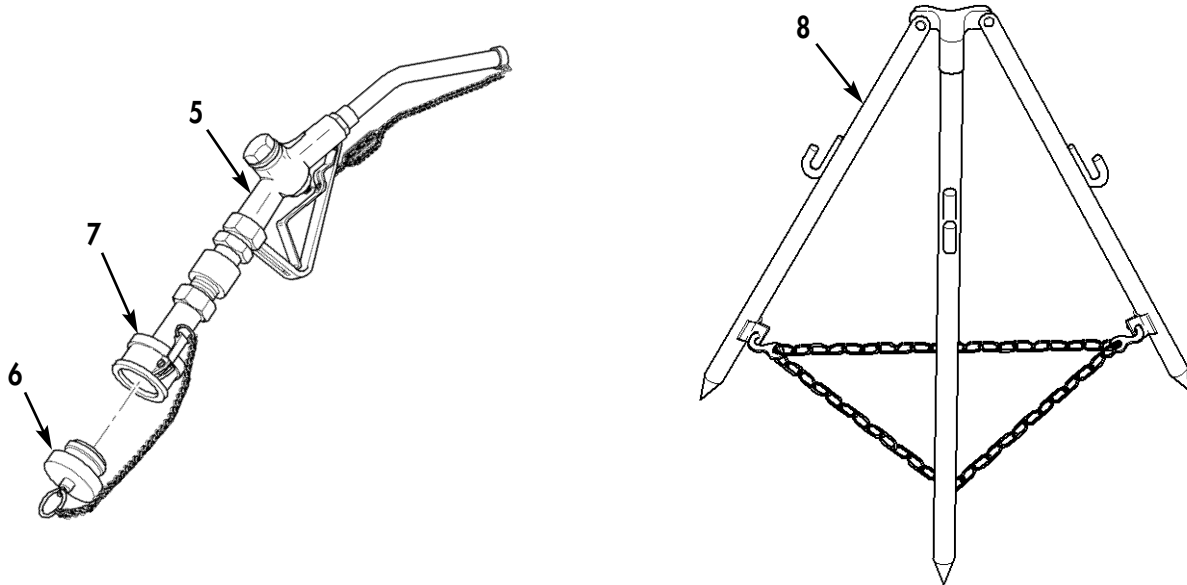

Figure 6. Nozzle and Stand.

END OF TASK

END OF WORK PACKAGE

OPERATOR INSTRUCTIONS
FORWARD AREA WATER POINT SUPPLY SYSTEM (FAWPSS)
DISASSEMBLY FOR MOVEMENT – MODEL M105
EFFECTIVE NOTICE
 Model M105

INITIAL SETUP

Materials/Parts

Shipping crates (WP 0050)

Equipment Condition

FAWPSS assembled for use (WP 0008).

WARNING

A partial full drum will allow motion of water due to forces resulting from transport. Never transport with more than one partially filled drum. Ensure remaining two drums are either full or as empty as they can be pumped out. Failure to comply may result in damage to equipment or possible injury to personnel.

NOTE

This work package covers disassembly after use of FAWPSS Model M105 as required prior to transport of equipment. Drums will be moved IAW WP 0009.

Ball valves are opened in step 1 to allow residual water to drain when disconnecting hoses.

1. Close coupler valves (Figure 1, Item 1) on three drums (Figure 1, Item 3), and open three ball valves (Figure 1, Item 4). Refer to WP 0004.
2. Drain pump by removing drain plug. Refer to WP 0004.

CAUTION

Ensure dust cap or plug is installed on open end of each coupling immediately after disconnecting. When disconnecting hoses and fittings, ensure a gasket is present prior to installing dust cap or plug. Failure to comply may result in contamination, loss of gasket, or damage to mating surfaces.

3. Disconnect 2 in. (51 mm) DIA x 10 ft (3 m) long suction hose assembly (Figure 1, Item 2) from coupler valve (Figure 1, Item 1) on three drums (Figure 1, Item 3), and install cap on coupling end of each hose assembly (Figure 1, Item 2).

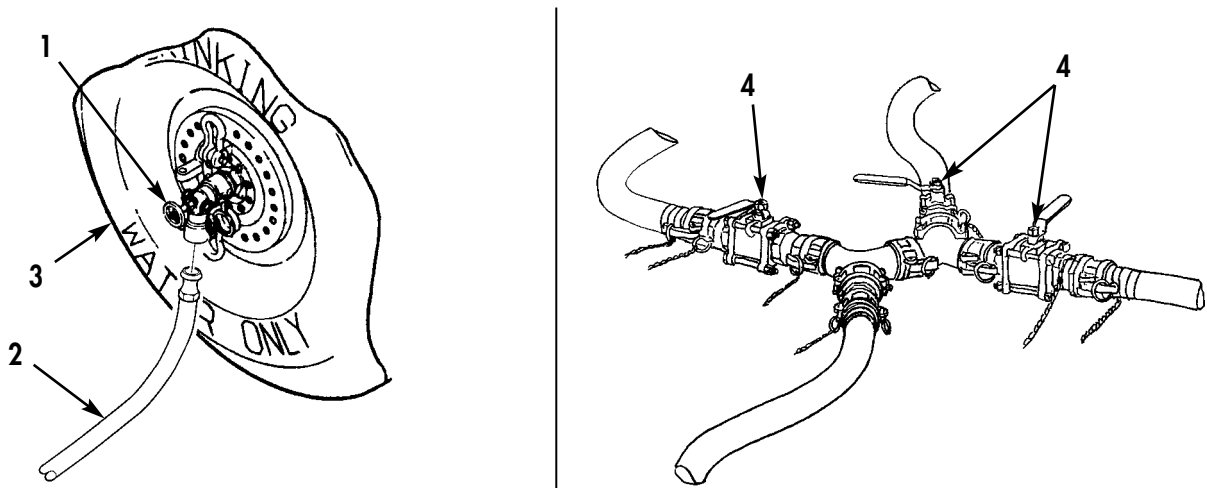

Figure 1. Coupler Valves and Ball Valves.

DISASSEMBLY FOR MOVEMENT— MODEL M105 (Contd)

4. Remove three 2 in. (51 mm) DIA x 10 ft (3 m) long suction hose assemblies (Figure 2, Item 1) from three ball valves (Figure 2, Item 2). Drain water and install plug on coupling end of each hose assembly (Figure 2, Item 1).
5. Remove three ball valves (Figure 2, Item 2) from two Y-fittings (Figure 2, Item 3), and install cap and plug on each ball valve (Figure 2, Item 2).
6. Remove two Y-fittings (Figure 2, Item 3) and male adapter (Figure 2, Item 5) from 2 in. (51 mm) DIA x 10 ft (3 m) long suction hose assembly (Figure 2, Item 4). Install caps and plugs.
7. Remove 2 in. (51 mm) DIA x 10 ft (3 m) long suction hose assembly (Figure 3, Item 4) from female quick-disconnect coupling (Figure 3, Item 10) on pump suction port of (Figure 3, Item 9). Drain water from hose assembly (Figure 3, Item 4) and install cap and plug.
8. Disconnect 2 in. (51 mm) DIA x 10 ft (3 m) long discharge hose assembly (Figure 3, Item 7) from male quick-disconnect coupling (Figure 3, Item 8) on pump discharge port of (Figure 3, Item 6). Install cap and plug.

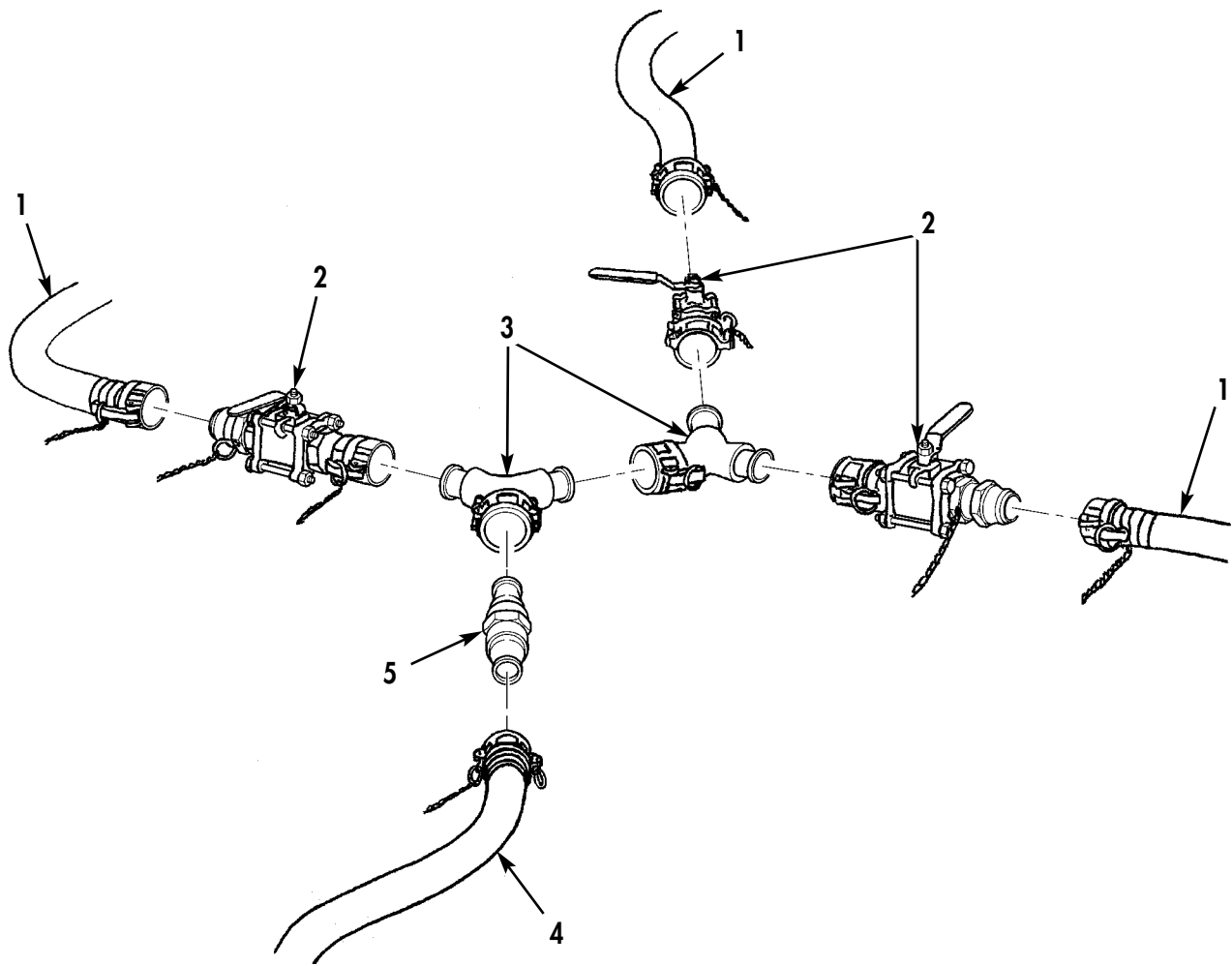

Figure 2. Disconnecting Hoses.

DISASSEMBLY FOR MOVEMENT— MODEL M105 (Contd)

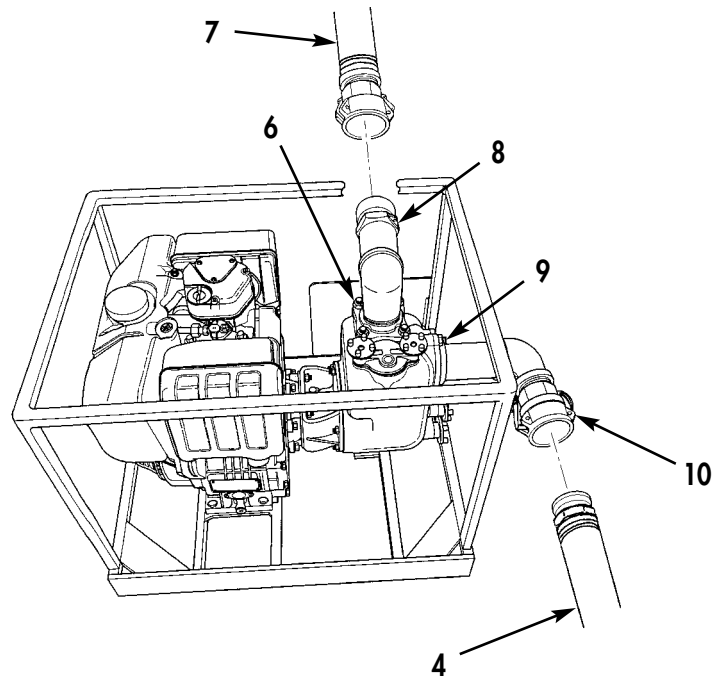

Figure 3. Disconnecting Pump.

9. Remove 2 in. (51 mm) DIA x 10 ft (3 m) long discharge hose assemblies (Figure 4, Item 7) from Y-fitting (Figure 4, Item 12). Drain water from hose and install cap.
10. Disconnect two 2 in. (51 mm) DIA x 25 ft (7.6 m) long discharge hose assemblies (Figure 4, Item 11) from Y-fitting (Figure 4, Item 12). Install two caps and plug on Y-fitting (Figure 4, Item 12).

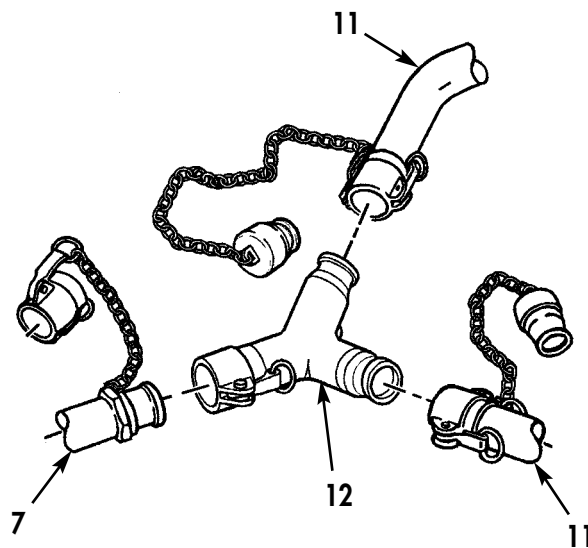

Figure 4. Disconnecting from Y-Fitting.

DISASSEMBLY FOR MOVEMENT— MODEL M105 (Contd)

11. Remove two 2 in. (51 mm) DIA x 25 ft (7.6 m) long discharge hose assemblies (Figure 5, Item 1) from two Y-fittings (Figure 5, Item 2). Lift each hose assembly (Figure 5, Item 1) over shoulder and walk hose line to drain water, then install caps and plugs on two hose assemblies (Figure 5, Item 1).

WARNING

To prevent contamination, leave nozzles hooked to stands when disconnecting hoses. Contamination may result in illness to personnel.

12. Remove four 1.5 in. (38 mm) DIA x 25 ft (7.6 m) long discharge hose assemblies (Figure 5, Item 3) from four reducers (Figure 5, Item 4) and four nozzle assemblies (Figure 5, Item 5). Lift each hose assembly (Figure 5, Item 3) over shoulder and walk hose line to drain water, then install caps and plugs on four hose assemblies (Figure 5, Item 3).
13. Remove four reducers (Figure 5, Item 4) from two Y-fittings (Figure 5, Item 2).

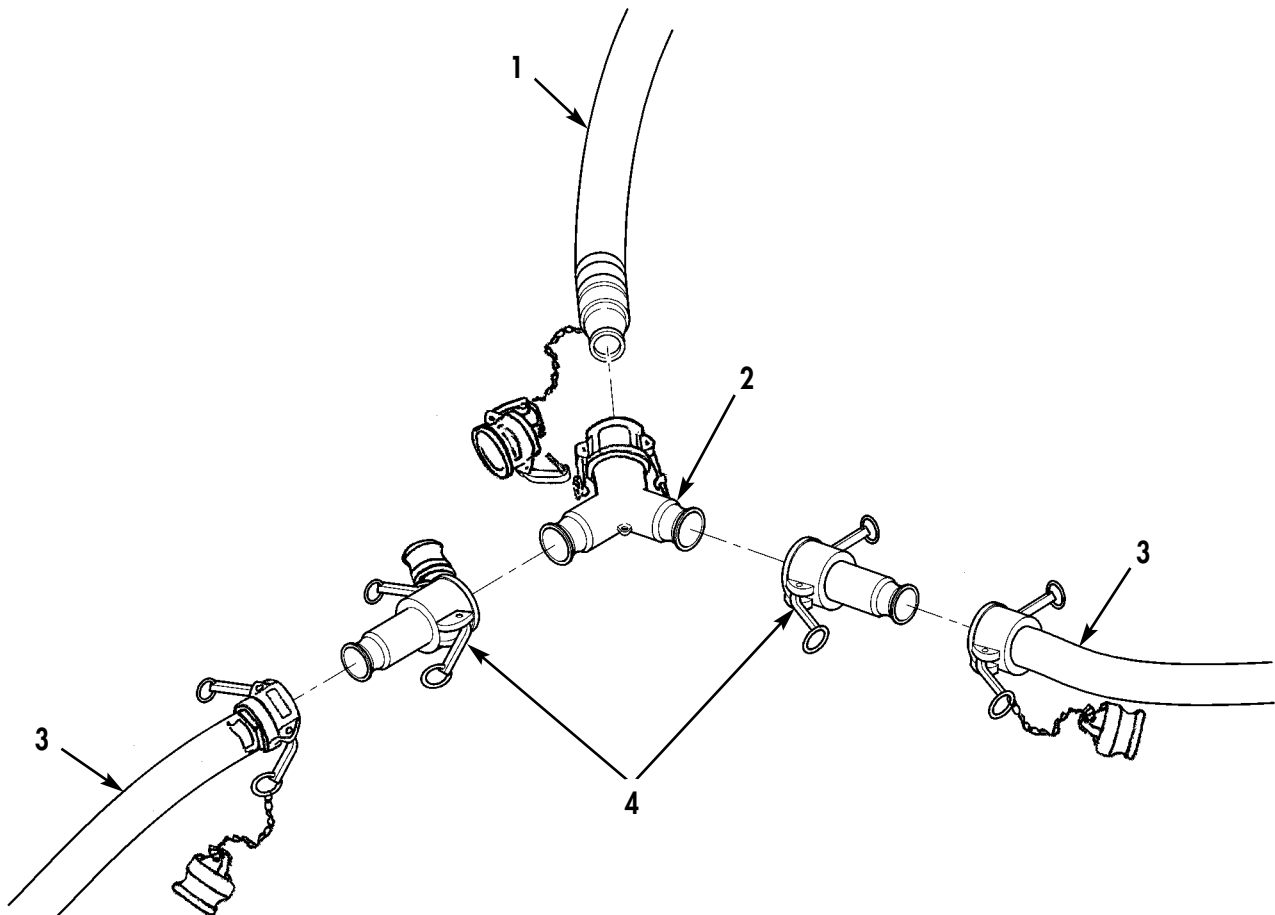

Figure 5. Disconnecting Hoses from Reducers and Nozzles.

DISASSEMBLY FOR MOVEMENT— MODEL M105 (Contd)

14. Install plug (Figure 6, Item 6) on each nozzle coupling (Figure 6, Item 7), and remove four nozzle assemblies (Figure 6, Item 5) from two nozzle stands (Figure 6, Item 8).
15. Fold two nozzle stand assemblies (Figure 6, Item 3). Refer to WP 0004.
16. Remove coupler valves from drums, and install plastic protective caps on adapter assemblies of drums. Refer to WP 0018.

CAUTION

Ensure FAWPSS equipment is packed in original shipping crates or suitable containers for transportation. Failure to comply may result in damage to equipment.

NOTE

The equipment crate provided for FAWPSS Model M105 contains a complete system minus the pump unit and drums. The pump and drums are packaged in separate crates. Refer to WP 0050 for shipping crate dimensions.

17. Pack all hose assemblies, valves, fittings, nozzle stands, pump unit, and drums in their respective crates. Refer to WP 0018.

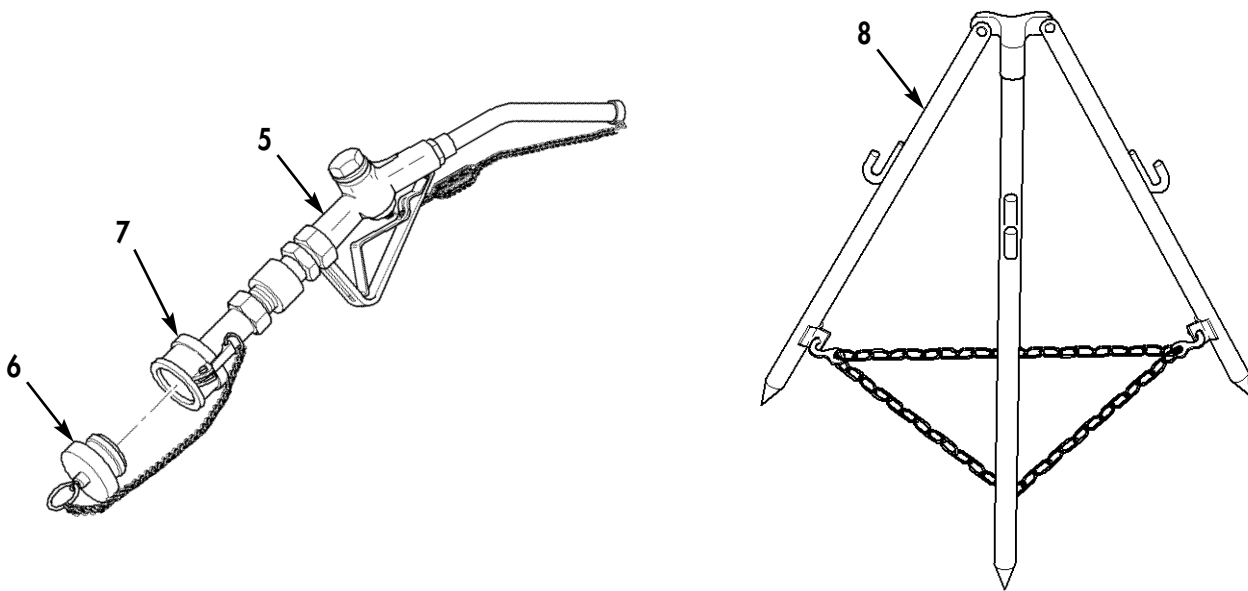

Figure 6. Nozzle and Stand.

END OF TASK

END OF WORK PACKAGE

**OPERATOR INSTRUCTIONS
FORWARD AREA WATER POINT SUPPLY SYSTEM (FAWPSS)
OPERATION UNDER UNUSUAL CONDITIONS**

INITIAL SETUP

References

FM 9-207
 FM 31-70
 FM 31-71
 TM 5-4320-368-14&P
 TM 10-5430-245-12&P
 TM 10-5430-247-13&P

Equipment Condition

FAWPSS assembled for operation
 (WP 0007 for LAB 9095 or WP 0008 for M105).
 PMCS performed (WP 0016).

GENERAL

This work package provides special instructions for operating and maintaining the FAWPSS under unusual conditions. Both FAWPSS Model LAB 9095 and Model M105 are designed to operate normally in a wide range of climate conditions. However, some conditions such as operating in extreme cold or arctic climates, extreme heat and humidity, high winds and dusty or sandy conditions, or salty air and sea spray conditions will require additional preparation or protective measures to prevent excessive wear or damage to the equipment. When operating under unusual conditions, it is especially important to keep the equipment properly maintained.

OPERATION UNDER UNUSUAL CONDITIONS INDEX

Operation in extreme Cold or Arctic Conditions WP 0012-1
 Operation in Extreme Heat and Humidity WP 0012-2
 Operation in High Winds and Dusty or Sandy Conditions WP 0012-3
 Operation in Salty Air and Sea Spray WP 0012-4
 Emergency Shutdown Procedure. WP 0012-4

OPERATION IN EXTREME COLD OR ARCTIC CONDITIONS

When operating the FAWPSS in temperatures below 32 F (0 C) down to -50 F (-45 C), the following steps will be followed to prevent damage to equipment and possible injury to personnel.

WARNING

Always wear gloves when handling FAWPSS equipment below freezing temperatures to prevent frost bite. Water can freeze very quickly and freeze skin to equipment on contact. Prevent water from contacting bare skin by always wearing winter gloves or arctic mittens. Failure to comply may result in injury to personnel.

CAUTION

Freezing water can damage FAWPSS components. When operating in temperatures below 32 F (0 C), keep drums from freezing, drain pump, and disconnect ends of all hoses or damage to equipment may result.

NOTE

For additional general information and technical guidance for operating equipment and ordnance materiel under extremely harsh cold weather conditions below 0° F (-17° C), refer to FM 9-207, FM 31-70, or FM 31-71.

OPERATION UNDER UNUSUAL CONDITIONS (Contd)**OPERATION IN EXTREME COLD OR ARCTIC CONDITIONS (Contd)**

1. Drums
 - a. Drums will be stored in a heated building, shelter, or tent and allowed to thaw before dispensing water.
 - b. Drums may become brittle in extreme cold, and care should be taken during movement or handling to avoid cracking drums.
 - c. Remove snow, ice, or sleet from drum before installing coupler valve.
2. Pump Unit
 - a. Remove snow, ice, or sleet prior to operating, and keep pump covered when not in use.
 - b. Keep fuel tank full to prevent condensation. Drain and service fuel filter more frequently than under normal operating conditions. Refer to TM 5-4320-368-14&P.
 - c. Perform PMCS on pump unit more frequently. Refer to TM 5-4320-368-14&P.
 - d. Prime pump with warm water to prevent freezing at start up.
 - e. Run engine at low idle to warm to operating temperature before running at high idle.
 - f. Drain pump immediate after operation. Refer to WP 0004.
3. Hoses, Valves, and Nozzles
 - a. Prior to use, remove any accumulation of snow or ice from nozzle assemblies.
 - b. Check for free movement of nozzle at swivel indicating freeze-up.
 - c. To prevent damage to hoses, valves, and nozzle assemblies from freeze-up of water in system, disconnect all hose ends from valves and fittings and allow residual water to drain.

END OF TASK**OPERATION IN EXTREME HEAT AND HUMIDITY**

1. Drums

CAUTION

Ensure drums are kept out of direct sunlight and as cool as possible. As temperature of water rises, expansion and pressure inside the drum will increase. Full drums may exceed maximum pressure and lead to damage to drum and possible loss of valuable water supply.

- a. Whenever possible, position drums under shade trees or cover with leafy branches.
 - b. Set up tent or tarpaulin over drums to provide shade.
 - c. Cover drums with wet burlap or other fabric, and keep fabric wet.
 - d. Do not block air circulation around drums.
2. Pump Unit
 - a. Ensure engine shrouding is complete and area between cooling fins is free from dirt and debris that would prevent sufficient flow of air.

OPERATION UNDER UNUSUAL CONDITIONS (Contd)**OPERATION IN EXTREME HEAT AND HUMIDITY (Contd)****WARNING**

Never operate pump unit in enclosed areas unless exhaust gases are piped outside. Exhaust gases contain carbon monoxide, a colorless, odorless, and poisonous gas, which can cause serious illness or death.

- b. If pump is operated in an enclosed area, allow for sufficient room around engine for air circulation, and ensure engine exhaust is properly vented outside.

CAUTION

Humid conditions can cause corrosion and deterioration of components. Keep fuel tank full at all times to prevent condensation. Failure to comply may result in damage to equipment.

- c. Cover pump unit with canvas or other waterproof cover during humid, rainy weather. Remove cover during dry weather to allow unit to dry out.
 - d. Perform PMCS on pump unit more frequently. Refer to TM 5-4320-368-14&P.
3. Hoses, Valves, and Nozzles
Allow residual water in hoses heated up by sunlight to clear from distribution points prior to filling drinking water containers.

END OF TASK**OPERATION IN HIGH WINDS AND DUSTY OR SANDY CONDITIONS**

1. Drums

WARNING

Drums used with FAWPSS Model LAB 9095 will be secured to ground by either banking soil along the sides of each drum, tying them to a secure structure such as a tree or vehicle, or staking them to the ground with rope. All personnel will stand clear of drums until properly secured or injury or death to personnel may result.

Drums used with FAWPSS Model M105 will be secured to PLS Flatrack or CROP platform with tiedown kit at all times.

- a. In strong winds, do not leave drums without properly anchoring them with ropes or tiedowns. Refer to TM 10-5430-245-12&P or TM 10-5430-247-13&P for FAWPSS Model M105.
 - b. Keep plastic protective caps on drums, and clean any dust or sand from adapter assemblies and coupler valves prior to connecting. Keep coupler valves covered when stored or not in use.
2. Pump Unit
 - a. Where possible, locate pump unit near natural barriers which offer protection from wind, dust, and sand, or shield pump unit with tactical vehicle or any other practical means.
 - b. Keep all protective dust caps and plugs installed when pump is not in use.
 - c. Strain fuel before adding to engine fuel tank, drain and service fuel filter more frequently, clean air filter daily, and remove dust and debris from exterior surfaces of pump unit frequently. Refer to TM 5-4320-368-14&P.

OPERATION UNDER UNUSUAL CONDITIONS (Contd)**OPERATION IN HIGH WINDS AND DUSTY OR SANDY CONDITIONS (Contd)**

3. Hoses, Valves, and Nozzles

WARNING

Water contaminated with dust or sand can severely affect the usability of the water. Ensure all hoses, valves, and fittings are clean before connecting, and immediately capped or plugged after disconnecting. Failure to comply may result in damage to equipment and injury to personnel.

- a. Ensure all caps and plugs are installed when not in use. Connect all adjoining plug and caps during assembly.
- b. Ensure nozzle dust caps are installed on spouts immediately after use.

END OF TASK**OPERATION IN SALTY AIR AND SEA SPRAY****CAUTION**

Salt water causes corrosive action on metal. Frequent cleaning of all exposed metal surfaces is necessary to remove salt residue. Failure to comply may result in damage to equipment.

1. After contact with salt water, wash exterior of all FAWPSS components with fresh water. Cleaning may be carried out by spraying or sponging exposed surfaces with fresh water.
2. Keep nozzle spouts free from dried salt to ensure drinking water is not contaminated when dispensed.

END OF TASK**EMERGENCY SHUTDOWN PROCEDURE**

Emergency shutdown of the FAWPSS is performed by immediately stopping engine on pump unit. Refer to WP 0004 for location and operation of engine shutoff, and TM 5-4320-368-14&P.

REPORTING MATERIAL FAILURE

Report failure of FAWPSS equipment on Standard Form 368 (Quality Deficiency Report—Equipment Improvement Recommendations) as presented by DA PAM 750-8 and as stated in WP 0001, Reporting Equipment Improvement Recommendations (EIR).

END OF TASK**END OF WORK PACKAGE**

CHAPTER 3

OPERATOR TROUBLESHOOTING PROCEDURES FOR FORWARD AREA WATER POINT SUPPLY SYSTEM (FAWPSS)

Operator Troubleshooting Symptom Index	WP 0013
Operator Troubleshooting Procedures	WP 0014

**OPERATOR MAINTENANCE
FORWARD AREA WATER POINT SUPPLY SYSTEM (FAWPSS)
TROUBLESHOOTING SYMPTOM INDEX**

<u>FAULT NO. / SYMPTOM DESCRIPTION TITLE</u>	<u>WORK PACKAGE/PAGE NO.</u>
1. Drums Leaking	0014-2
2. Coupler Valve Leaking or Inoperable.	0014-2
3. Ball Valve Leaking or Inoperable.	0014-3
4. Water Leaking from Hose Assembly	0014-3
5. Nozzle Assembly Leaking	0014-4
6. Components Leaking at Places other than Coupling Connections	0014-4
7. Pump Unit Engine Will Not Start	0014-5
8. Pump Unit Starts But Does Not Pump Water	0014-5
9. Pump Unit Does Not Pump Water at Rated Capacity	0014-5
10. Water has Unusual Odor	0014-6

END OF WORK PACKAGE

**OPERATOR MAINTENANCE
FORWARD AREA WATER POINT SUPPLY SYSTEM (FAWPSS)
TROUBLESHOOTING PROCEDURES**

INITIAL SETUP**References**

DA Form 2404
DA Form 5504
DA Form 5988-E
TM 5-4320-368-14&P
TM 10-5430-245-12&P
TM 10-5430-247-13&P

Equipment Condition

FAWPSS assembled, LAB 9095 (WP 0007) or
M105 (WP 0008).

INTRODUCTION

This work package contains operator level troubleshooting procedures for correcting unsatisfactory operation and basic equipment malfunctions of the FAWPSS.

Each troubleshooting procedure lists a fault symptom describing a specific problem. Under each symptom is a list of possible malfunctions in the order of probability that may be the cause of the problem. Finally, a corrective action is provided for each malfunction followed by a work package or TM reference or instruction to notify unit maintenance to correct the problem.

Prior to performing any troubleshooting procedure, the following recommendations should be observed.

NOTE

This manual cannot list all possible malfunctions that may occur.
If the symptom for a particular problem or malfunction is not listed
in this work package, notify your supervisor.

1. Isolate the component where the malfunction occurs by finding the symptom that most accurately describes the problem.
2. Perform troubleshooting procedure in the order in which steps are listed.
3. Consider the possibility that the problem could be simple in origin and may require only minor adjustment; use common sense.
4. If a problem cannot be corrected after performing all corrective actions listed for a given symptom, notify your supervisor.
5. If the corrective action is not authorized at the operator level, operators should provide a brief written description of the problem using Equipment Inspection and Maintenance Worksheet, DA Form 2404 or DA Form 5988-E, and Maintenance Request Form, DA Form 5504.

TROUBLESHOOTING PROCEDURES (Contd)

1. DRUMS LEAKING

SYMPTOM

Water leaking from drum

MALFUNCTION

Adapter assembly leaking

CORRECTIVE ACTION

STEP 1. Depress and release pin at center of adapter assembly to seat check valve and release any possible debris lodged in check valve.

STEP 2. If leaking persists, notify unit maintenance.

MALFUNCTION

Water leaking around bearing plate, swivel plate, or closure ring of drum

CORRECTIVE ACTION

Notify unit maintenance to check for loose mounting hardware.

MALFUNCTION

Puncture or cut in drum body

CORRECTIVE ACTION

STEP 1. Locate puncture or cut. If hole is 3/8 in. (9.5 mm) DIA or less, plug hole using drum repair kit. Refer to WP 0030.

STEP 2. If hole is larger than 3/8 in. (9.5 mm), notify unit maintenance.

2. COUPLER VALVE LEAKING OR INOPERABLE

SYMPTOM

Coupler valve leaking

MALFUNCTION

Water leaking from connection between coupler valve and adapter assembly

CORRECTIVE ACTION

STEP 1. Ensure both cam arms are locked tight. Refer to WP 0004. If loose, tighten. If both cam levers are tight and coupler valve is loose at connection, proceed to next step.

STEP 2. Disconnect coupler valve from adapter assembly and check for debris or missing or damaged gasket. Replace missing or damaged gasket and connect coupler valve. If coupler valve still cannot be locked tight or still leaks at connection, notify unit maintenance.

MALFUNCTION

Coupler valve leaks at valve stem and packing nut

CORRECTIVE ACTION

Notify unit maintenance to tighten packing nut.

MALFUNCTION

Coupler valve leaks at outlet when disconnected from system

CORRECTIVE ACTION

Ensure coupler valve handwheel is turned to the left (counterclockwise) all the way. Refer to WP 0004. If valve still leaks, notify unit maintenance.

MALFUNCTION

Coupler valve handwheel is difficult or impossible to turn

CORRECTIVE ACTION

Notify unit maintenance.

TROUBLESHOOTING PROCEDURES (Contd)**3. BALL VALVE LEAKING OR INOPERABLE****SYMPTOM**

Ball valve leaks

MALFUNCTION

Water leaking from connection between ball valve and hose or Y-fitting

CORRECTIVE ACTION

- STEP 1. Ensure both cam arms are locked tight. Refer to WP 0004. If loose, tighten. If both cam arms are tight and ball valve is loose at connection, proceed to next step.
- STEP 2. Disconnect ball valve where leaking and check for missing or damaged gasket. Replace missing or damaged gasket and connect ball valve. If ball valve still cannot be locked tight or still leaks at connection, notify unit maintenance.

MALFUNCTION

Ball valve leaks at valve stem

CORRECTIVE ACTION

Notify unit maintenance.

MALFUNCTION

Ball valve lever is difficult or impossible to turn

CORRECTIVE ACTION

Notify unit maintenance.

4. WATER LEAKING FROM HOSE ASSEMBLY**SYMPTOM**

Water leaks from hose or leaks at connection

MALFUNCTION

Puncture, crack, or cut in hose, or missing or damaged hose clamps at coupling ends

CORRECTIVE ACTION

Replace hose assembly.

MALFUNCTION

Water leaking at hose connection

CORRECTIVE ACTION

- STEP 1. Ensure both cam arms are present and locked tight. Refer to WP 0004. If either cam arm is missing or damaged, replace hose assembly. If loose, tighten. If both cam arms are tight and hose is loose at connection, proceed to next step.
- STEP 2. Disconnect hose where leaking and check for debris or missing or damaged gasket. Replace missing or damaged gasket and connect hose. If hose still cannot be locked tight or still leaks at connection, proceed to next step.
- STEP 3. Check opposite fitting at connection for damage. Replace opposite fitting if damaged. If opposite fitting is satisfactory, replace hose assembly.

TROUBLESHOOTING PROCEDURES (Contd)

5. NOZZLE ASSEMBLY LEAKING

SYMPTOM

Water leaks from nozzle spout, valve, swivel, or coupling at hose connection

MALFUNCTION

Water will not shut off at spout

CORRECTIVE ACTION

Check for sticking lever or valve. If found sticking or damaged, notify unit maintenance.

MALFUNCTION

Water leaking from valve stem

CORRECTIVE ACTION

Notify unit maintenance.

MALFUNCTION

Water leaking from swivel

CORRECTIVE ACTION

Notify unit maintenance.

MALFUNCTION

Water leaking from coupling at hose connection

CORRECTIVE ACTION

- STEP 1. Ensure both cam arms are present and locked tight. Refer to WP 0004. If either cam arm is missing or damaged, notify unit maintenance. If loose, tighten. If both cam arms are tight and hose is loose at connection, proceed to next step.
- STEP 2. Disconnect hose from nozzle coupling and check for debris or missing or damaged gasket. Replace missing or damaged gasket and connect hose. If hose still cannot be locked tight or still leaks at connection, notify unit maintenance.

6. COMPONENTS LEAKING AT PLACES OTHER THAN COUPLING CONNECTIONS

SYMPTOM

Water leaking from fittings at pump suction or discharge ports or pump shaft or casing

MALFUNCTION

Water leaks from pipe fittings on pump

CORRECTIVE ACTION

Notify unit maintenance.

MALFUNCTION

Water leaks from pump shaft or casing

CORRECTIVE ACTION

Notify unit maintenance.

TROUBLESHOOTING PROCEDURES (Contd)

7. PUMP UNIT ENGINE WILL NOT START

Refer to operator troubleshooting in pump unit TM. Refer to TM 5-4320-386-14&P.

8. PUMP UNIT STARTS BUT DOES NOT PUMP WATER

SYMPTOM

No water at nozzles

MALFUNCTION

Coupler valves and or ball valves closed

CORRECTIVE ACTION

Open designated coupler valve and ball valve. Refer to Operating Procedures (WP 0005).

MALFUNCTION

Pump not primed before first operation or loses prime

CORRECTIVE ACTION

STEP 1. Prime pump unit. Refer to WP 0005

STEP 2. If pump was primed after first operation and lost its prime after a brief shutdown, notify unit maintenance.

MALFUNCTION

Collapsed hose or obstructed nozzle assembly

CORRECTIVE ACTION

STEP 1. Replace collapsed hose.

STEP 2. Disconnect nozzle assembly and clear obstruction. If obstruction is not found and water flows from hose at distribution point, notify unit maintenance.

9. PUMP UNIT DOES NOT PUMP WATER AT RATED CAPACITY

SYMPTOM

Water delivered at low volume or low pressure

MALFUNCTION

Engine running at low idle

CORRECTIVE ACTION

STEP 1. Adjust engine to high idle. Refer to TM 5-4320-386-14&P.

STEP 2. If engine will not run at sufficient high idle, refer to operator troubleshooting in appropriate pump unit TM.

MALFUNCTION

Coupler valve, ball valve, or nozzle assembly improperly set

CORRECTIVE ACTION

STEP 1. Check that handwheel on coupler valve is turned all the way to the right. Refer to WP 0004.

STEP 2. Check that ball valve lever is in the open position. Refer to WP 0004.

STEP 3. Check travel of nozzle valve when lever is fully up. Notify unit maintenance if nozzle valve appears to not open fully.

TROUBLESHOOTING PROCEDURES (Contd)

10. WATER HAS UNUSUAL ODOR

SYMPTOM

Water coming from drum has unusual odor at distribution points

MALFUNCTION

Residual water left in hoses has set for extended period

CORRECTIVE ACTION

- STEP 1. Allow water to run from all nozzles at each distribution point until water is free from odor.
- STEP 2. If odor does not go away after clearing residual water from hoses, notify unit maintenance.

WARNING

FAWPSS drums are authorized to be filled with potable drinking water only. If it is suspected that a drum has been used for holding any liquid other than potable water, do not use water or drum. Failure to comply may result in sickness or death to personnel.

MALFUNCTION

Drum is contaminated.

CORRECTIVE ACTION

- STEP 1. Disconnect contaminated drum from system and notify unit maintenance.
- STEP 2. Connect FAWPSS to another drum known to contain clean potable water, and allow residual water in system to flush out from all nozzles at each distribution point until water is free from odor.

CHAPTER 4

OPERATOR MAINTENANCE INSTRUCTIONS/PMCS FOR FORWARD AREA WATER POINT SUPPLY SYSTEM (FAWPSS)

Preventive Maintenance Checks and Services (PMCS) Introduction	WP 0015
Preventive Maintenance Checks and Services (PMCS) and Lubrication Instructions	WP 0016
Maintenance	WP 0017

**OPERATOR MAINTENANCE
FORWARD AREA WATER POINT SUPPLY SYSTEM (FAWPSS)
PREVENTIVE MAINTENANCE CHECKS AND SERVICES (PMCS)
INTRODUCTION**

GENERAL

PMCS is required to keep the equipment in good operating condition. Operator level PMCS is performed before, during, and after operation to ensure the equipment is fully operational and ready at all times. Failure to perform PMCS as required may result in major damage or a failure which could compromise the mission or cause injury to personnel. Operators will perform PMCS as follows:

- a. Ensure PMCS is performed each time the FAWPSS is operated.
- b. If the equipment is being operated for the first time or has not been operated for a three month period, notify unit maintenance to perform quarterly PMCS inspection.
- c. If the equipment has been operated for three months or a 250 hours of operation (whichever comes first) notify unit maintenance to perform quarterly PMCS inspection.
- d. Observe all warnings, cautions, and notes when performing PMCS.
- e. Always perform PMCS in the same order as written. With practice, this will enable operators to become familiar with the equipment and enable them to quickly spot anything wrong with the equipment.
- f. Before operating the FAWPSS, perform all "Before" PMCS steps.
- g. During operation of the FAWPSS, perform "During" PMCS steps.
- h. After operating the FAWPSS, perform all "After" PMCS steps.
- i. At any PMCS interval, if the item to be checked or serviced is found to be not ready or available, that problem must be corrected by troubleshooting and, if necessary, notifying unit maintenance to perform the task.
- j. Ensure operator PMCS for the FAWPSS storage drums and pump unit are performed each time the FAWPSS is operated. Refer to References, WP 0044, for the applicable TM for the storage drum and the pump unit.
- k. Whenever the equipment is found to be not ready or available and the problem cannot be resolved at the operator level, describe what is wrong with the equipment using DA Form 2404. This will document the problem and help unit maintenance locate and correct it. For information on how to use this form, see DA PAM 750-8.

PREVENTIVE MAINTENANCE CHECKS AND SERVICES (PMCS) INTRODUCTION (Contd)**PURPOSE OF PMCS TABLE**

The purpose of the PMCS table is to provide a systematic method of inspection and servicing of the equipment. In this way, small defects can be detected early and corrected before they become a major problem causing the equipment to fail. The PMCS table is arranged with the individual PMCS procedures listed in sequence under assigned intervals. The most logical time (before, during, and after operation) to perform each procedure determines the interval to which it is assigned. Make a habit of performing the checks in the same order each time; anything wrong will be seen quickly. Refer to WP 0016 for Operator PMCS.

The following is a list and description of the column headings in the PMCS table.

- a. Item Number — This column shows the sequence in which the checks and services are to be performed, and is used to identify the equipment area on the Equipment Inspection and Maintenance Worksheet, DA Form 2404 or DA Form 5988-E.
- b. Interval — This column indicated when each check is to be performed.
- c. Item To Be Checked Or Serviced — This column identifies the item and location to be checked by part, component, or assembly name.
- d. Procedure — This column explains what type of service, specific damage, or defect is to be checked.
- e. Equipment Not Ready/Available If: — This column lists conditions that make the equipment unavailable for use as a result of damage, missing parts, or improper functioning that would present a safety hazard. Do not accept or operate equipment with a condition noted in this column.

CORROSION PREVENTION AND CONTROL (CPC)

Corrosion Prevention and Control (CPC) is a continuing concern. It is important that any corrosion problems with this equipment be reported so improvements can be made and future problems eliminated.

Corrosion is typically associated with rusting of metals or galvanic corrosion, which produces a white powder. This category of corrosion also includes deterioration of other materials such as rubber and plastic. Unusual cracking, softening, swelling, or breaking of materials may be the result of corrosion. If a corrosion problem is identified, it can be reported using SF 368, Product Quality Deficiency Report. Use of key words such as "Corrosion", "rust," "deterioration," or "cracking" will ensure the information is identified as a CPC problem. The form should be submitted to the address specified in DA PAM 750-8.

PREVENTIVE MAINTENANCE CHECKS AND SERVICES (PMCS) INTRODUCTION (Contd)**ARMY OIL ANALYSIS PROGRAM (AOAP)**

The FAWPSS is not enrolled in the AOAP. HARDTIME INTERVALS APPLY.

FLUID LEAKAGE

It is necessary to know how fluid leakage affects the status of the FAWPSS. The following types/classes of leakage are defined to enable the operator to be able to determine the status of the FAWPSS equipment should a leak occur. It is essential that operators learn to identify the type/class of leak by definition and, when in doubt, notify their supervisor.

CAUTION

Equipment operation is allowed with minor leakage's (Class I or II). Consideration must be given to fluid capacity in the item/system being checked/inspected. When in doubt, notify your supervisor. Failure to comply may result in damage to equipment.

When operating with Class I or II leaks, continue to check fluid levels as required in PMCS table. Class III leaks will be reported immediately to your supervisor.

- a. Class I – Seepage of fluid (as indicated by wetness or discoloration) not great enough to form drops.
- b. Class II – Leakage of fluid great enough to form drops but not enough to cause drops to drip from item being checked/inspected.
- c. Class III – Leakage of fluid great enough to form drops that fall from item being checked/inspected.

SPECIAL INSTRUCTIONS**NOTE**

If the FAWPSS must be kept in continuous operation, check and service only those items that must be checked during operation without shutting down the equipment.

Preventive maintenance is not limited to performing the checks and services listed in the PMCS table. When performing PMCS check all components as follows:

WARNING

Cleaning solvent compound Skysol 100 mixture is combustible. Use mechanical ventilation whenever product is used in a confined space. DO NOT use or store near heat, sparks, flame, or other ignition sources. Keep container sealed when not in use.

PREVENTIVE MAINTENANCE CHECKS AND SERVICES (PMCS) INTRODUCTION (Contd)**SPECIAL INSTRUCTIONS (Contd)****WARNING**

Contact with Skysol 100 may cause skin irritation. Use chemical-resistant gloves. In case of skin contact, remove any contaminated clothing before reuse. Eye contact may cause irritation, tearing, or blurring of vision. Use face shield or goggles when eye contact may occur. In case of eye contact, flush eyes with large amounts of water for at least fifteen (15) minutes or until irritation subsides.

Inhalation may cause irritation to upper respiratory passages. DO NOT have food or drink in the vicinity. Failure to comply may result in injury or death to personnel.

To prevent contamination, do not clean internal surfaces of any FAWPSS hose, valve, or fitting with cleaning solvent compound Skysol 100. Failure to comply may result in injury to personnel.

Compressed air source must not exceed 30 psi (207 kPa). When cleaning with compressed air, eye shields must be worn. Failure to comply may result in injury to personnel.

- a. Keep it clean – Dirt, grease, oil, and debris get in the way and may cover up a serious problem. Clean work area as needed. Use Skysol 100 to clean oil and grease from all exterior metal surfaces of equipment. Use a soap and water solution to clean dirt and debris from all exterior and interior surfaces, and rinse thoroughly with clean water.
- b. Bolts, nuts, and screws – Check them all for obvious looseness, missing, bent, or broken condition. Look for corrosion around bolt heads. If mounting hardware is loose, damaged, or corroded, notify unit maintenance.
- c. Wiring harness, wires, and connectors – Look for cracked or broken wiring where present. If damaged wiring or loose connections are found, notify unit maintenance.

**OPERATOR MAINTENANCE
FORWARD AREA WATER POINT SUPPLY SYSTEM (FAWPSS)
PREVENTIVE MAINTENANCE CHECKS AND SERVICES (PMCS)
AND LUBRICATION INSTRUCTIONS**

INITIAL SETUP

Equipment Condition

FAWPSS assembled for operation
(WP 0007 for LAB 9095 or
WP 0008 for M105).

GENERAL

This PMCS uses the one-look format and applies to both FAWPSS Model LAB 9095 and FAWPSS Model M105. Beginning at the storage drums, proceed to the ball valves, pump unit, and distribution point nozzles, checking all hoses and connections along the way.

While performing PMCS, ensure components and assemblies are correctly installed. Incorrect installation may cause equipment damage or failure.

When checking/servicing an item, ensure that all attaching/mounting hardware is properly secured. Loose, cracked, broken, or missing hardware may affect equipment performance or cause premature failure.

LUBRICATION

Lubrication of the FAWPSS is limited to required lubrication of the pump unit engine assembly. No lubrication is needed for all other FAWPSS components. Refer to References, WP 0044, for the applicable TM for the pump unit.

Table 1. Operator Preventive Maintenance Checks and Services for FAWPSS.

ITEM NO.	INTERVAL	ITEM TO BE CHECKED OR SERVICED	PROCEDURE	EQUIPMENT NOT READY/ AVAILABLE IF:
1	Before	Drums and Coupler Valves	Perform operator PMCS IAW applicable TM. Refer To References, WP 0044.	
2	Before	Pump Unit	Perform operator PMCS IAW applicable TM. Refer To References, WP 0044.	

PREVENTIVE MAINTENANCE CHECKS AND SERVICES (PCMS) AND LUBRICATION INSTRUCTIONS (Contd)

Table 1. Operator Preventive Maintenance Checks and Services for FAWPSS (Contd).

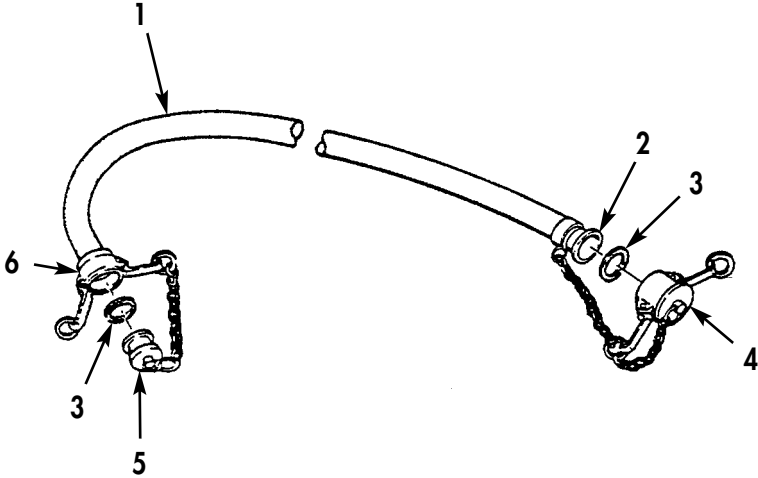
ITEM NO.	INTERVAL	ITEM TO BE CHECKED OR SERVICED	PROCEDURE	EQUIPMENT NOT READY/ AVAILABLE IF:
3	Before	Hose Assemblies (Figure 1, Item 1)	<ol style="list-style-type: none"> 1. Check for damaged or missing gaskets (Figure 1, Item 3). 2. Check for cuts or cracks in hose (Figure 1, Item 1). 3. Check coupling halves (Figure 1, Item 2) and (Figure 1, Item 6) and dust cap (Figure 1, Item 4) and plug (Figure 1, Item 5) for damage or if missing and contamination has resulted. 	<ol style="list-style-type: none"> 1. Gaskets are damaged or missing. 2. Hose is cut or cracked. 3. Coupling halves, cap, or plug is damaged or hose assembly is contaminated.
			<p>Figure 1. Hose Assembly.</p>	
4.	Before	Ball Valve Assemblies (Figure 2, Item 6)	<ol style="list-style-type: none"> 1. Check for damaged or missing gaskets (Figure 2, Item 2). 2. Check for cracks or damage that would result in leaks. 3. Check coupling halves (Figure 2, Item 3) and (Figure 2, Item 5), dust cap (Figure 2, Item 4), and plug (Figure 1, Item 1) for damage or if missing and contamination has resulted. 	<ol style="list-style-type: none"> 1. Gaskets are damaged or missing. 2. Cracks or damage is Found. 3. Coupling halves, cap, or plug is damaged or ball valve assembly is contaminated.

PREVENTIVE MAINTENANCE CHECKS AND SERVICES (PCMS) AND LUBRICATION INSTRUCTIONS (Contd)

Table 1. Operator Preventive Maintenance Checks and Services for FAWPSS (Contd).

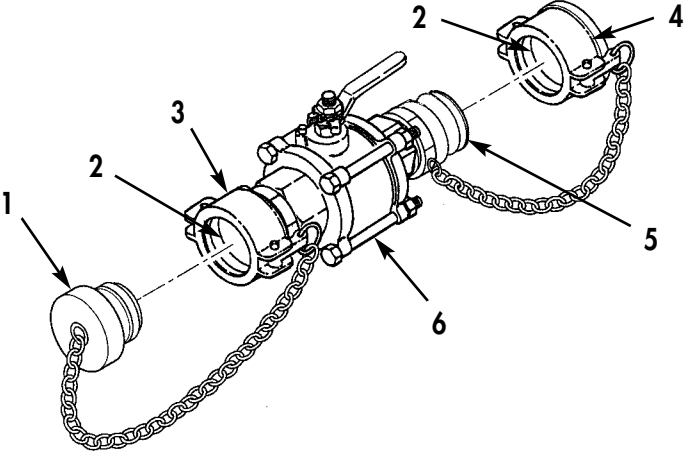
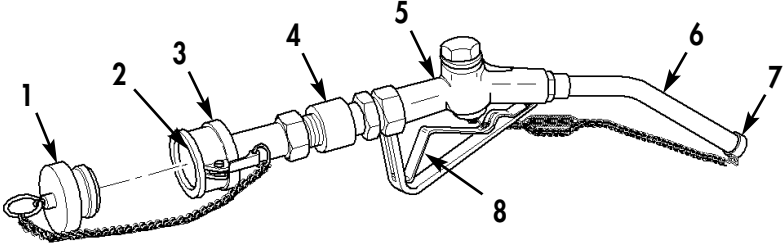
ITEM NO.	INTERVAL	ITEM TO BE CHECKED OR SERVICED	PROCEDURE	EQUIPMENT NOT READY/ AVAILABLE IF:
			 <p data-bbox="667 821 1040 852"><i>Figure 2. Ball Valve Assembly.</i></p>	
5	Before	Nozzle Assemblies (Figure 3, Item 5)	<ol style="list-style-type: none"> <li data-bbox="667 867 1040 951">1. Check for damaged or missing gasket (Figure 3, Item 2). <li data-bbox="667 972 1040 1087">2. Check control handle (Figure 3, Item 8) and swivel (Figure 3, Item 4) for smooth operation. <li data-bbox="667 1108 1040 1360">3. Check coupling half (Figure 3, Item 3), dust plug (Figure 3, Item 1), nozzle spout (Figure 3, Item 6) and protective cap (Figure 3, Item 7) for damage or if missing and contamination has resulted. 	<ol style="list-style-type: none"> <li data-bbox="1083 867 1456 930">1. Gasket is damaged or missing. <li data-bbox="1083 972 1456 1035">2. Control handle or swivel is jammed. <li data-bbox="1083 1108 1456 1192">3. Coupling half, dust plug, spout, or protective cap is contaminated.
			 <p data-bbox="690 1896 1015 1927"><i>Figure 3. Nozzle Assembly.</i></p>	

PREVENTIVE MAINTENANCE CHECKS AND SERVICES (PCMS) AND LUBRICATION INSTRUCTIONS (Contd)

Table 1. Operator Preventive Maintenance Checks and Services for FAWPSS (Contd).

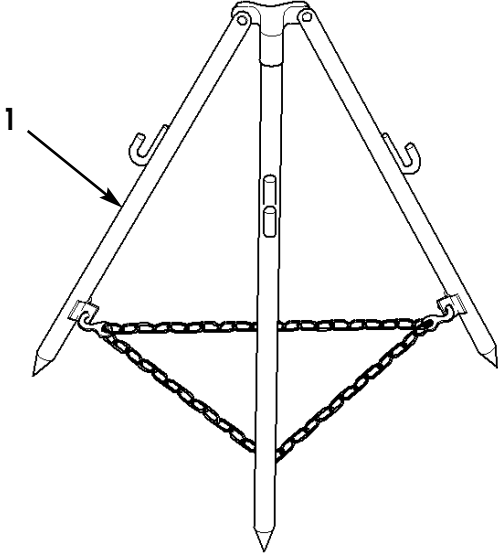
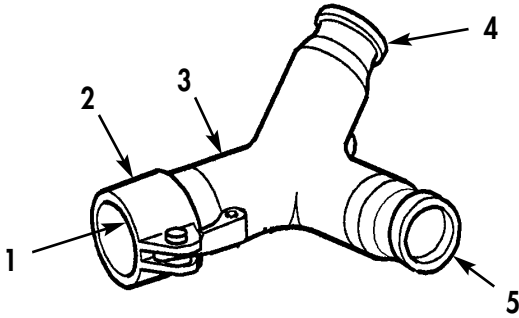
ITEM NO.	INTERVAL	ITEM TO BE CHECKED OR SERVICED	PROCEDURE	EQUIPMENT NOT READY/ AVAILABLE IF:
6	Before	Nozzle Stand Assemblies (Figure 4, Item 1)	<p>Check for damaged or missing parts.</p>  <p style="text-align: center;"><i>Figure 4. Nozzle Stand Assembly.</i></p>	Stand cannot be used due to damaged or missing parts.
7	Before	Y-fittings (Figure 5, Item 3)	<ol style="list-style-type: none"> 1. Check for damaged or missing gaskets (Figure 5, Item 1). 2. Check coupling half (Figure 5, Item 2), male coupling ends (figure 5, Item 4) and (figure 5, Item 5) for damage or if contamination has resulted.  <p style="text-align: center;"><i>Figure 5. Y-fitting.</i></p>	<ol style="list-style-type: none"> 1. Gasket is damaged or missing. 2. Dust plug or any coupling half is damaged or contamination has resulted.

PREVENTIVE MAINTENANCE CHECKS AND SERVICES (PCMS) AND LUBRICATION INSTRUCTIONS (Contd)

Table 1. Operator Preventive Maintenance Checks and Services for FAWPSS (Contd).

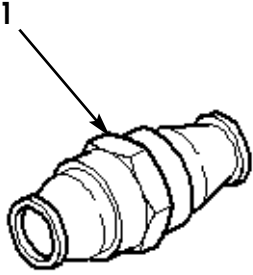
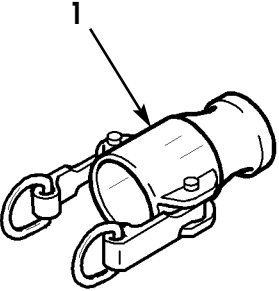
ITEM NO.	INTERVAL	ITEM TO BE CHECKED OR SERVICED	PROCEDURE	EQUIPMENT NOT READY/ AVAILABLE IF:
8	Before	Male Adapter (Figure 6, Item 1)	Check for cracks or damaged mating surfaces.  <p style="text-align: center;"><i>Figure 6. Male Adapter.</i></p>	Cracks or damage to mating surfaces is found.
9	Before	2 in. (51 mm) to 1.5 in. (38 mm) Reducers (Figure 7, Item 1)	Check for cracks or damaged mating surfaces.  <p style="text-align: center;"><i>Figure 7. Reducer.</i></p>	Cracks or damage to mating surfaces is found.
10	Before	Miscellaneous Fittings	Check for cracks or damaged mating surfaces.	Cracks or damage to mating surfaces is found.

PREVENTIVE MAINTENANCE CHECKS AND SERVICES (PCMS) AND LUBRICATION INSTRUCTIONS (Contd)

Table 1. Operator Preventive Maintenance Checks and Services for FAWPSS (Contd).

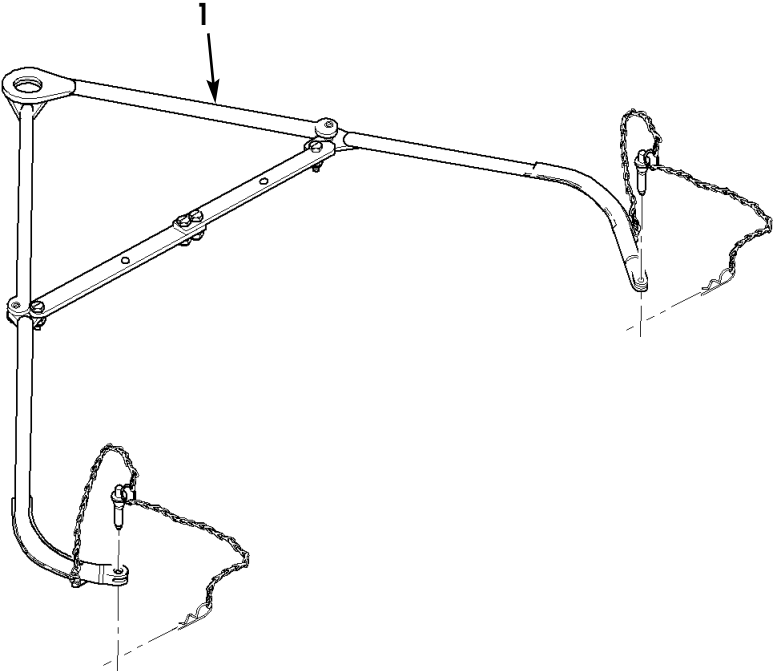
ITEM NO.	INTERVAL	ITEM TO BE CHECKED OR SERVICED	PROCEDURE	EQUIPMENT NOT READY/ AVAILABLE IF:
11	Before	Fuel Cans	Check for cracks or damage that would result in leaks.	Any cracks or damage is found.
12	Before	Towing and Lifting Yoke (Figure 8, Item 1)	<p style="text-align: center;">NOTE</p> <p>Perform step 12 for FAWPSS Model LAB 9095 only.</p> <p>Check for damaged or missing parts.</p>	Yoke cannot be used due to damaged or missing parts.
			<p><i>Figure 8. Towing and Lifting Yoke.</i></p>	
13	Before	Tiedown Kit	<p style="text-align: center;">NOTE</p> <p>Perform step 13 for FAWPSS Model M105 only.</p> <p>Check twelve tiedown chains (Figure 9, Item 1), ten tiedown straps (Figure 9, Item 2), and sixteen protective sleeves (Figure 9, Item 3) for damage or if missing.</p>	Any tiedown chain or strap cannot be operated or is missing.

PREVENTIVE MAINTENANCE CHECKS AND SERVICES (PCMS) AND LUBRICATION INSTRUCTIONS (Contd)

Table 1. Operator Preventive Maintenance Checks and Services for FAWPSS (Contd).

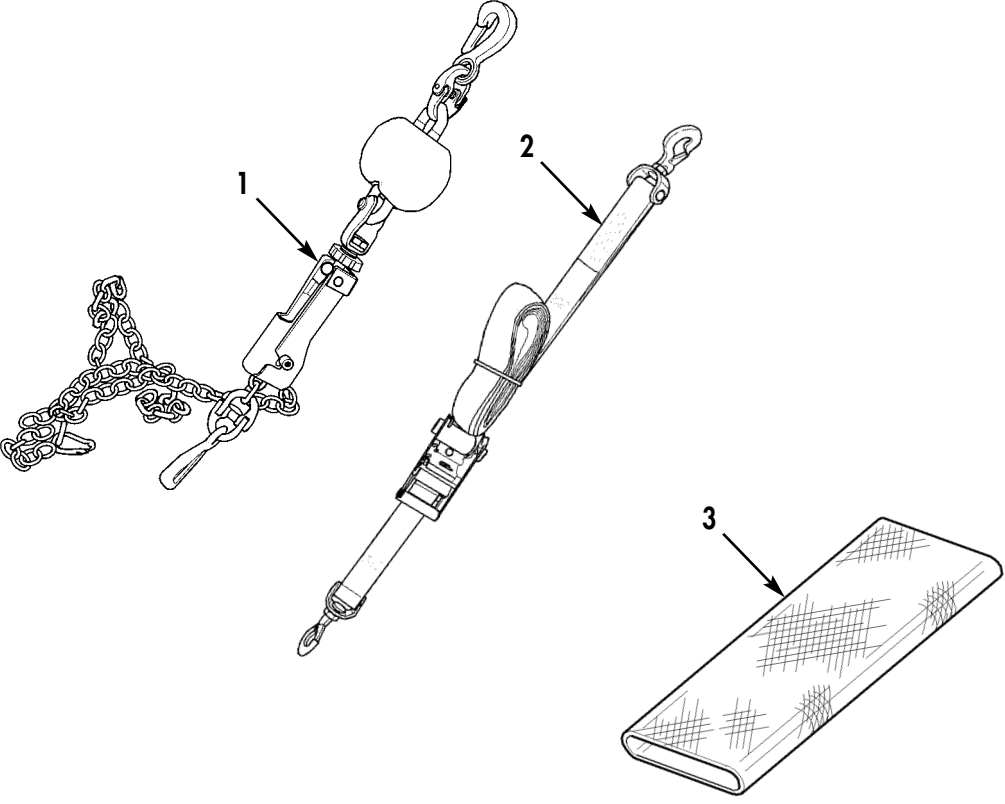
ITEM NO.	INTERVAL	ITEM TO BE CHECKED OR SERVICED	PROCEDURE	EQUIPMENT NOT READY/ AVAILABLE IF:
			 <p data-bbox="649 1249 1047 1312"><i>Figure 9. Tiedown Kit, FAWPSS Model M105.</i></p>	
14	During	Drums and coupler valves	<p data-bbox="787 1333 917 1360">CAUTION</p> <p data-bbox="649 1375 1047 1585">Equipment operation is allowable with minor leakage (Class I or II). Operating with a Class III leak may result in damage to equipment. Report any class III leak to supervisor immediately.</p> <p data-bbox="649 1606 1047 1764">When operating with minor leakage (Class I or II), ensure fluid levels are checked more frequently or damage to equipment may result.</p> <p data-bbox="649 1774 1047 1837">Check for leaks. Refer to applicable TM.</p>	Any Class III leak is found.
15	During	Pump Unit	Check for leaks. Refer to applicable TM.	Any class III Leak is found.

PREVENTIVE MAINTENANCE CHECKS AND SERVICES (PCMS) AND LUBRICATION INSTRUCTIONS (Contd)

Table 1. Operator Preventive Maintenance Checks and Services for FAWPSS (Contd).

ITEM NO.	INTERVAL	ITEM TO BE CHECKED OR SERVICED	PROCEDURE	EQUIPMENT NOT READY/ AVAILABLE IF:
16	During	All Hose Assemblies	Check for leaks. Refer to applicable TM.	Any Class III leak is found.
17	During	Ball Valve Assemblies	Check for leaks. Refer to applicable TM.	Any class III Leak is found.
18	During	Nozzle Assemblies	Check for smooth operation and leaks. Refer to applicable TM.	Nozzle does not shut off when lever is released or any Class III leak is found.
19	During	All Y-fittings, adapter, reducers, and coupling halves	Check for leaks. Refer to applicable TM.	Any class III Leak is found.
20	After	Tiedown chains and straps	<p style="text-align: center;">NOTE</p> Perform step 20 for FAWPSS Model M105 only. Loosen tiedown chains and tighten tiedown straps on emptied drums. Refer to WP 0009.	Slack is not removed from loose tiedown straps prior to movement.

END OF WORK PACKAGE

**OPERATOR MAINTENANCE
FORWARD AREA WATER POINT SUPPLY SYSTEM (FAWPSS)
MAINTENANCE**

INITIAL SETUP: Not Applicable.

GENERAL

WARNING

Operators are authorized to remove and replace damaged or malfunctioning FAWPSS component assemblies only. No tools other than those provided in the BII are authorized for operator use. Do not attempt to make adjustments or repairs to any individual component or assembly. Send all defective items to unit maintenance. Failure to comply may result in damage to equipment and possible injury to personnel.

Operator maintenance is limited to the replacement of any FAWPSS component assembly or individual part that fails to function properly. This means any component found to be not fully mission capable while performing operator PMCS (WP 0016) or determined to have failed or malfunctioned by performing operator troubleshooting (WP 0014) will be disconnected from the system and exchanged with an identical functional component. Send all failed components to unit maintenance for further troubleshooting, maintenance, or repair.

If the FAWPSS fails to operate properly after assembly, refer to WP 0014.

DRUM AND PUMP UNIT MAINTENANCE

1. For temporary repair of drum body due to small punctures, refer to WP 0009. For specific instructions governing operator maintenance of the collapsible fabric drum, refer to TM 10-5430-245-12&P or TM 10-5430-247-13&P.
2. For specific information governing operator maintenance of the centrifugal pump unit, refer to TM 5-4320-368-14&P.

END OF TASK

END OF WORK PACKAGE

CHAPTER 5

UNIT MAINTENANCE INSTRUCTIONS/PMCS FOR FORWARD AREA WATER POINT SUPPLY SYSTEM (FAWPSS)

Service Upon Receipt of Material	WP 0018
Preventive Maintenance Checks and Services (PMCS) Introduction	WP 0019
Preventive Maintenance Checks and Services (PMCS) and Lubrication Instructions	WP 0020
Hose Assembly Maintenance	WP 0021
Ball Valve Assembly Maintenance	WP 0022
Nozzle Assembly Maintenance	WP 0023
Nozzle Stand Assembly Maintenance	WP 0024
Towing and Lifting Yoke Maintenance	WP 0025
Miscellaneous Fittings Maintenance	WP 0026
Tiedown Assemblies Maintenance	WP 0027
General Maintenance	WP 0028

**UNIT MAINTENANCE
FORWARD AREA WATER POINT SUPPLY SYSTEM (FAWPSS)
SERVICE UPON RECEIPT OF MATERIAL**

INITIAL SETUP**Personnel Required**

Two

ReferencesSF 361
DA PAM 750-8

GENERAL

This work package contains procedures for unloading, unpacking, checking unpacked equipment, installation instructions, assembly of equipment, and preliminary servicing of equipment to ensure it is complete and in working condition prior to assembly and use of the FAWPSS. If the equipment contents are not checked for completeness or damage first, there is a chance the mission could be compromised.

When unpacking, each item will be checked against the packing list provided. Report all missing items or discrepancies IAW applicable service instructions. Refer to DA PAM 750-8, The Army Maintenance Management System (TAMMS) Users Manual.

All items will be checked for damage incurred during shipment, and any item found to be damaged will be reported on SF 631, Transport Discrepancy Report.

SITTING REQUIREMENTS

Unloading, unpacking, and checking FAWPSS equipment will be performed upon receipt of material prior to each mission. To perform this requirement, unpack and perform all assembly and maintenance at a site having a level open area free from debris and sharp rocks. Refer to WP 0006 for specific sitting requirements.

END OF TASK**UNLOADING****WARNING**

When lifting or maneuvering heavy equipment, ensure sufficient personnel are on hand to do the job. Use proper physical lifting procedures, wear protective equipment such as gloves and steel-toed shoes, and if necessary, use a dolly or suitable lifting device to save time and effort. Failure to comply may result in damage to equipment and possible injury to personnel.

Both models of the FAWPSS are shipped in wooden crates. All crates may be either lifted by fork-lift or with straps or sling and a suitable overhead lifting device. Crates will be placed on a level flat surface for proper support. If the available ground or support surface is not even, use scrap boards to block the bottom of the crates until evenly supported. This is particularly important if the crates will be re-used; the crates may buckle and come apart once opened, if not evenly supported.

END OF TASK

SERVICE UPON RECEIPT OF MATERIAL (Contd)**UNPACKAGING****NOTE**

FAWPSS equipment shipping crates are designed to be retained for re-use for mobility purposes when frequent relocation of the system is anticipated.

The FAWPSS is fielded as one complete system per TRICON container. Inside each TRICON are two wooded crates held in place by two large cargo straps. The contents of FAWPSS Model LAB 9095 are shipped as follows: Drum crate (bottom crate) contains six drums and drum accessory hardware. Component crate (top crate) contains the pump unit and all FAWPSS accessory hardware. The contents of FAWPSS Model M105 are shipped as follows: Drum crate (bottom crate) contains three drums and drum accessory hardware. Component crate (top crate) contains the pump unit, all FAWPSS accessory hardware, and tiedown kit. Refer to tables 1 and 2 for a complete inventory list per shipping crate for each model. Perform the following steps for unloading crates.

1. Remove two cargo straps (Figure 1, Item 3) from drum crate (Figure 1, Item 4) and component crate (Figure 1, Item 1), and carefully remove component crate (Figure 1, Item 1) and drum crate (Figure 1, Item 4) from TRICON container (Figure 1, Item 2).

CAUTION

If crates will be reused, exercise caution not to damage them when opening and unpacking. If crates will be discarded, be careful not to damage their contents when opening. Failure to comply may result in damage to equipment.

2. Check stenciling (Figure 1, Item 7) and packing slip for correct NSN to verify crate contents.
3. If crates are secured to truck or carrier, remove all tiedown straps necessary to open crates.
4. Check all crates for visible damage indicating probable damage to contents. Notify supervisor if notable damage is found prior to opening any crates.
5. If crates are unloaded to ground, ensure each crate is evenly supported on ground before opening.

NOTE

Perform steps 6, 7 and 9 for BCT configuration. Assistant will help remove crate panels as clamps are removed from crates. Do not discard clamps if crates will be re-used.

6. For each crate, mark location of top panel (Figure 1, Item 5), two side panels (Figure 1, Item 1), and end panels (Figure 1, Item 8) with base (Figure 1, Item 9) for future installation.
7. Carefully remove all clamps (Figure 1, Item 6) from top panels (Figure 1, Item 5) of crates by prying each clamp (Figure 1, Item 6) from crate brackets (Figure 1, Item 10). Remove top panel (Figure 1, Item 5).
8. Locate and remove equipment packing list envelope attached to the inside of crate, and put it in a safe place.
9. Remove two side panels (Figure 1, Item 1) and end panels (Figure 1, Item 8) from base (Figure 1, Item 9) by prying and removing all remaining clamps (Figure 1, Item 6) from crate brackets (Figure 1, Item 10).

CAUTION

Use caution when removing hoses and drums from crates to avoid puncturing them on sharp objects. Failure to comply may result in damage to equipment.

NOTE

Note location of all items prior to unpacking.

10. Remove items from crates one at a time and place on ground for identification.
11. Unwrap and check each item against the equipment packing list provided. Refer to table 1 for FAWPSS LAB 9095 Inventory List. Refer to table 2 for FAWPSS M105 Inventory List.

SERVICE UPON RECEIPT OF MATERIAL (Contd)

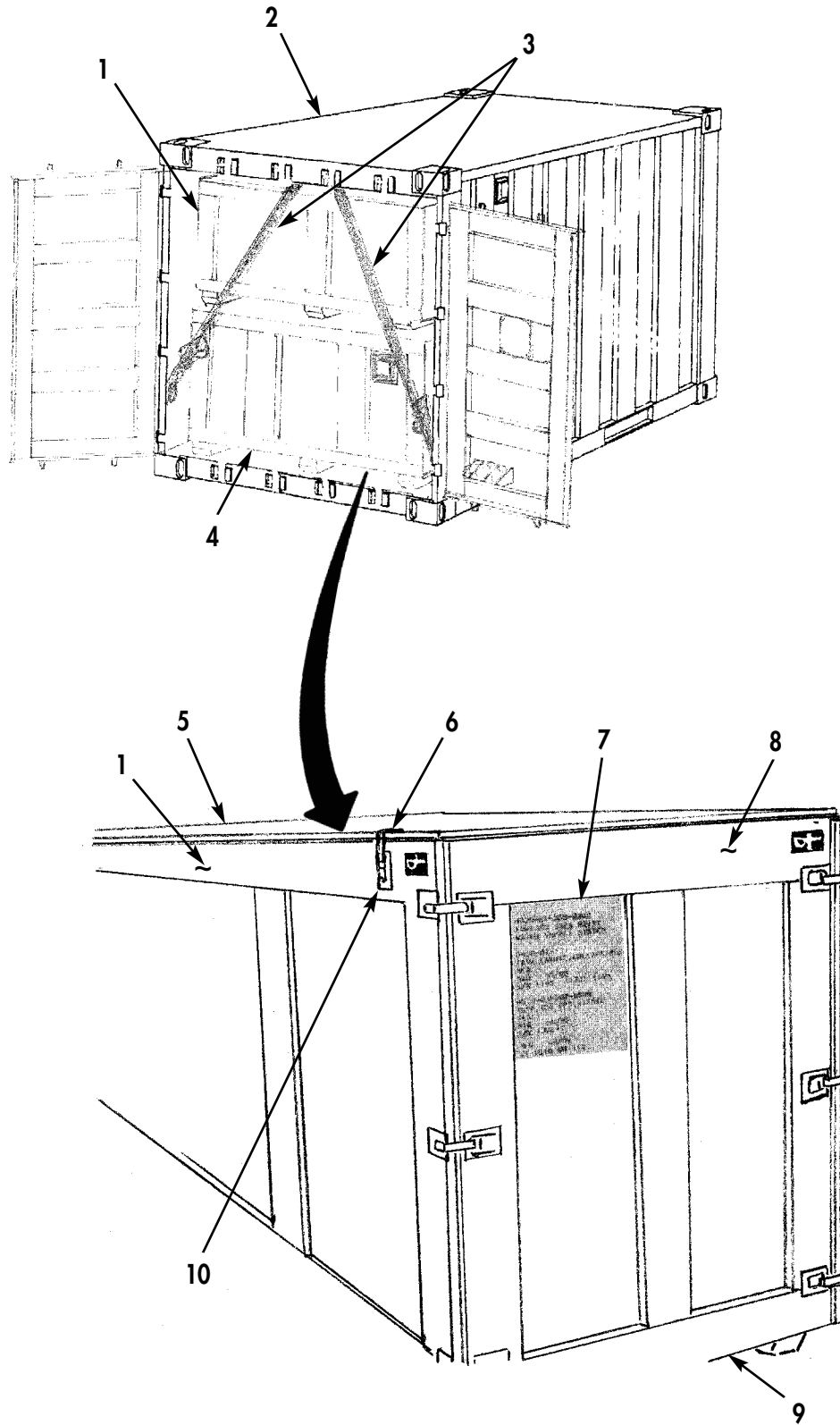

Figure 1. FAWPPS Model M105 Shipping Crate Shown.

END OF TASK

SERVICE UPON RECEIPT OF MATERIAL (Contd)

Table 1. FAWPSS Model Lab 9095 Inventory List.

NSN	ITEM	QUANTITY
8145-01-475-9570	TRICON Container	1
3040-01-387-4048	Connecting Link, Rigid, CTC-1012-23-1	3
3990-01-204-3009	Tiedown, Cargo, vehicle, FDC5770-5	2
DRUM CRATE		
5430-01-527-4514 (GTA) 8110-01-122-0015 (Amfuel)	Drum Assy. Collapsible Fabric, 500 Gal	6
8110-00-856-6244	Repair Kit, ATPD 2263 Type 1, MIL-R-52255	6
4820-01-167-6550	Valve, Elbow, Coupler, FQD 2 in. x 2 in., 13219E491	12
TM 10-5430-245-12&P or TM 10-5430-247-13&P	Manual, Technical, Operator's/Parts, 500 Gal. Fab. Drum	1
COMPONENT CRATE		
4320-01-507-0598	Pump, 125 GPM, Diesel, 56913030	1
TM 5-4320-368-14&P	Manual, Technical, Operator's & Maint, Pump, 125 GPM	1
On pump	Street Elbow, 2 in. DIA. MNPT x FNPT	1
On Pump	Elbow, 2 in. DIA, Internal Pipe threads	1
On Pump	Nipple, Pipe, 2 in. DIA x 2 in. Length	1
On Pump	Nipple, Pipe, 2 in. DIA x 6 in. Length	1
4730-00-079-1362	Coupling Half, QD, FQD x FNPT, AA59326/1A6A	1
4370-00-088-9285	Coupling Half, FQD x MNPT 2 in., MS270026-11	1
4820-000330-5466	Valve Assy, Ball, 2 in., 13225E9137-2	2
4730-00-938-7997	Coupling Half, FQD x MNPT, 2 in., MS 27022-11	1
4730-00-649-9103	Coupling Half, FQD x FNPT, 2 in., MS27024-11	1
4730-00-915-5127	Coupling Half, QD, Plug, Dust, 2 in., MS27029-11	1
4730-00-649-9100	Coupling Half, QD, Cap, Dust, 2 in. MS27028-11	1
4730-01-009-1735	Adapter, MQD x MQD, 2 in. x 2in., MS39352-9	1
4730-00-951-3295	Reducer, QD, 2 in. F x 1.5 in. M, MS49000-5	4
4730-01-068-5070	Wye Fitting, Coupler Double Adapter, 2in., 1321E0477	4
4610-01-188-8197	Nozzle Assy, FQD, 1 in., 13225E9094-2	4
4930-01-120-7426	Stand Assy, Nozzle, 13225E9140	2
8110-00-856-6243	Yoke, Towing and Lifting for Drums, 13216E7991	1
7240-01-337-5268	Fuel, 5 Cal, Plastic, MIL-C-53109	2
7240-00-177-6154	Spout, Can, Flexible, MIL-S-1285	1
8030-00-889-3535	Tape, Antiseize, size 2, MIL-T-27730	3
4720-01-163-5088	Hose Assy, Discharge, 2 in. x 10 ft, 13225E9136-1	1
4720-01-163-4683	Hose Assy, Suction, 2in x 10 ft, 13225E9135-1	3
4720-01-175-5957	Hose Assy, Discharge, 2 in. x 25 ft, 13225E9136-5	2
4720-01-174-8173	Hose Assy, Discharge, 1.5 in x 25 ft, 13225E9136-11	4
5330-00-360-0595	Gasket, QD, 1.5 in., AA59326-5	14
5330-00-612-2414	Gasket, QD, 2in., AA59326-G6	14
TM 10-4320-346-12&P	Manual, Technical, Operator's/Parts for FAWPSS	1

SERVICE UPON RECEIPT OF MATERIAL (Contd)

Table 2. FAWPSS Model M105 Inventory List.

NSN	ITEM	QUANTITY
8145-01-475-9570	TRICON Container	1
3040-01-387-4048	Connecting Link, Rigid, CTC-1012-23-1	3
3990-01-204-3009	Tiedown, Cargo, vehicle, FDC5770-5	2
DRUM CRATE		
5430-01-527-4514 (GTA) 8110-01-122-0015 (Amfuel)	Drum Assy. Collapsible Fabric, 500 Gal	3
8110-00-856-6244	Repair Kit, ATPD 2263 Type 1, MIL-R-52255	3
4820-01-167-6550	Valve, Elbow, Coupler, FQD 2 in. x 2 in., 13219E491	6
TM 10-5430-245-12&P or TM 10-5430-247-13&P	Manual, Technical, Operator's/Parts, 500 Gal. Fab. Drum.	1
COMPONENT CRATE		
4320-01-507-0598	Pump, 125 GPM, Diesel, 56913030	1
TM 5-4320-368-14&P	Manual, Technical, Operator's & Maint, Pump, 125 GPM	1
On pump	Street Elbow, 2 in. DIA. MNPT x FNPT	1
On Pump	Elbow, 2 in. DIA, Internal Pipe threads	1
On Pump	Nipple, Pipe, 2 in. DIA x 2 in. Length	1
On Pump	Nipple, Pipe, 2 in. DIA x 6 in. Length	1
4730-00-079-1362	Coupling Half, QD, FQD x FNPT, AA59326/1A6A	1
4370-00-088-9285	Coupling Half, FQD x MNPT 2 in., MS270026-11	4
4820-000330-5466	Valve Assy, Ball, 2 in., 13225E9137-2	3
4730-00-938-7997	Coupling Half, FQD x MNPT, 2 in., MS 27022-11	1
4730-00-649-9103	Coupling Half, FQD x FNPT, 2 in., MS27024-11	1
4730-00-915-5127	Coupling Half, QD, Plug, Dust, 2 in., MS27029-11	4
4730-00-649-9100	Coupling Half, QD, Cap, Dust, 2 in. MS27028-11	7
4730-01-009-1735	Adapter, MQD x MQD, 2 in. x 2in., MS39352-9	1
4730-00-951-3295	Reducer, QD, 2 in. F x 1.5 in. M, MS49000-5	4
4730-01-068-5070	Wye Fitting, Coupler Double Adapter, 2in., 1321E0477	5
4610-01-188-8197	Nozzle Assy, FQD, 1 in., 13225E9094-2	4
4930-01-120-7426	Stand Assy, Nozzle, 13225E9140	2
7240-01-337-5268	Fuel, 5 Cal, Plastic, MIL-C-53109	2
7240-00-177-6154	Sput, Can, Flexible, MIL-S-1285	1
8030-00-889-3535	Tape, Antiseize, size 2, MIL-T-27730	3
4720-01-163-5088	Hose Assy, Discharge, 2 in. x 10 ft, 13225E9136-1	1
4720-01-163-4683	Hose Assy, Suction, 2in x 10 ft, 13225E9135-1	4
4720-01-175-5957	Hose Assy, Discharge, 2 in. x 25 ft, 13225E9136-5	2
4720-01-174-8173	Hose Assy, Discharge, 1.5 in x 25 ft, 13225E9136-11	4
5330-00-360-0595	Gasket, QD, 1.5 in., AA59326-5	14
5330-00-612-2414	Gasket, QD, 2in., AA59326-G6	7
5325-00-926-5411	Ring, Retaining, Split, H01434M	15
TM 10-4320-346-12&P	Manual, Technical, Operator's/Parts for FAWPSS	1
	Tiedown Kit, Drum, 15MTC/1668A	1

SERVICE UPON RECEIPT OF MATERIAL (Contd)**ASSEMBLY OF EQUIPMENT**

The FAWPSS pump unit may require the installation of pipe fittings and cam-locking quick-disconnect couplings on the pump suction and discharge ports when received new for the first time. If the pump unit does not have these fittings installed when unpacked, refer to WP 0026 for their installation.

END OF TASK**PRELIMINARY SERVICING OF EQUIPMENT**

Refer to PMCS procedures in WP 0016 of this TM for instructions on lubrication requirements prior to operating equipment.

END OF TASK**END OF WORK PACKAGE**

**UNIT MAINTENANCE
FORWARD AREA WATER POINT SUPPLY SYSTEM (FAWPSS)
PREVENTIVE MAINTENANCE CHECKS AND SERVICES (PMCS)
INTRODUCTION**

GENERAL

Unit Maintenance PMCS is performed at quarterly intervals to ensure the equipment is fully operational and ready at all times. Maintaining the FAWPSS requires inspection on a regular basis so minor damage or faults can be discovered and corrected. Performing unit PMCS is essential to the reliability and expected longevity of the equipment. Failing to correct a minor problem may result in major damage or a complete failure of the equipment which could compromise the mission or result in injury to personnel.

Any effective preventive maintenance program must begin with the training of operators to report equipment problems to unit maintenance as noted during daily operator PMCS. This information will be recorded by the operator on DA Form 2404, Equipment Inspection and Maintenance Worksheet. The Maintainer will use this information during maintenance inspections to verify and correct the problem. The corrective action taken will also be recorded on DA Form 2404 by the maintainer.

Maintainers will perform unit PMCS as follows:

- a. A schedule for unit preventive maintenance inspection and service should be established immediately after installation of the FAWPSS.
- b. If the equipment is operated for the first time or has not been operated for a three month period, perform quarterly PMCS inspection using the operator PMCS table. Refer to WP 0016.
- c. If the equipment has been operated for three months or a 250 hours of operation (whichever comes first) perform quarterly PMCS inspection following operator PMCS table. Refer to WP 0016.
- d. When operating under unusual conditions such as in a dusty or sandy environment, it may be necessary to increase the interval from quarterly to monthly or even weekly, if conditions are extreme.
- e. Observe all warnings, cautions, and notes when performing PMCS.
- f. Always perform PMCS in the same order as written.
- g. At any PMCS interval, if the item to be inspected is found to be not ready or available, that item must be corrected by troubleshooting and making the necessary repair.
- h. Ensure unit PMCS for the FAWPSS storage drums and pump unit are performed during each FAWPSS quarterly inspection. Refer to References, WP 0044, for the applicable TM for the storage drum and the pump unit
- i. Whenever the equipment is found to be not ready or available and the problem could not be resolved at the operator level, refer to DA Form 2404 for the operator's description of the problem.

PURPOSE OF PMCS TABLE

The purpose of the PMCS table is to provide a systematic method of inspection of the equipment. In this way, small defects can be detected early and corrected before they become a major problem causing the equipment to fail. The PMCS table is arranged with the individual PMCS procedures listed in sequence under assigned intervals. The most logical time (before, during, and after operation) to perform each procedure determines the interval to which it is assigned. Make a habit of performing the checks in the same order each time; anything wrong will be seen quickly. Refer to WP 0020 for Unit PMCS.

The following is a list and description of the column headings in the PMCS table.

- a. Item Number — This column shows the sequence in which the inspection is to be performed, and is used to identify the equipment area on the Equipment Inspection and Maintenance Worksheet, DA Form 2404 or DA Form 5988-E.
- b. Interval — This column indicated when each check is to be performed.
- c. Item To Be Checked Or Serviced — This column identifies the item and location to be checked by part, component, or assembly name.
- d. Procedure — This column explains what type of service, specific damage, or defect is to be checked.
- e. Equipment Not Ready/Available If: - This column lists conditions that make the equipment unavailable for use as a result of damage, missing parts, or improper functioning that would present a safety hazard. Do not accept or operate equipment with a condition noted in this column.

PREVENTIVE MAINTENANCE CHECKS AND SERVICES (PCMS) INTRODUCTION (Contd)**CORROSION PREVENTION AND CONTROL (CPC)**

Corrosion Prevention and Control (CPC) is a continuing concern. It is important that any corrosion problems with this equipment be reported so improvements can be made and future problems eliminated.

Corrosion is typically associated with rusting of metals or galvanic corrosion, which produces a white powder. This category of corrosion also includes deterioration of other materials such as rubber and plastic. Unusual cracking, softening, swelling, or breaking of materials may be the result of corrosion. If a corrosion problem is identified, it can be reported using SF 368, Product Quality Deficiency Report. Use of key words such as "Corrosion", "rust," "deterioration," or "cracking" will ensure the information is identified as a CPC problem. The form should be submitted to the address specified in DA PAM 750-8.

ARMY OIL ANALYSIS PROGRAM (AOAP)

The FAWPSS is not enrolled in the AOAP. HARDTIME INTERVALS APPLY.

FLUID LEAKAGE

It is necessary to know how fluid leakage affects the status of the FAWPSS. The following types/classes of leakage are defined to enable the operator to be able to determine the status of the FAWPSS equipment should a leak occur. It is essential that operators learn to identify the type/class of leak by definition and, when in doubt, notify their supervisor.

CAUTION

Equipment operation is allowed with minor leakage's (Class I or II).
Consideration must be given to fluid capacity in the item/system being checked/inspected. When in doubt, notify your supervisor.
Failure to comply may result in damage to equipment.

When operating with Class I or II leaks, continue to check fluid levels as required in PMCS table. Class III leaks will be reported immediately to your supervisor.

- a. Class I – Seepage of fluid (as indicated by wetness or discoloration) not great enough to form drops.
- b. Class II – Leakage of fluid great enough to form drops but not enough to cause drops to drip from item being checked/inspected.
- c. Class III – Leakage of fluid great enough to form drops that fall from item being checked/inspected.

PREVENTIVE MAINTENANCE CHECKS AND SERVICES (PCMS) INTRODUCTION (Contd)**ADDITIONAL INSTRUCTIONS****NOTE**

If the FAWPSS must be kept in continuous operation, check and service only those items that must be checked during operation without shutting down the equipment.

When performing PMCS, check all components as follows:

WARNING

Cleaning solvent compound Skysol 100 mixture is combustible. Use mechanical ventilation whenever product is used in a confined space. DO NOT use or store near heat, sparks, flame, or other ignition sources. Keep container sealed when not in use.

Contact with Skysol 100 may cause skin irritation. Use chemical-resistant gloves. In case of skin contact, remove any contaminated clothing before reuse. Eye contact may cause irritation, tearing, or blurring of vision. Use face shield or goggles when eye contact may occur. In case of eye contact, flush eyes with large amounts of water for at least fifteen (15) minutes or until irritation subsides.

Inhalation may cause irritation to upper respiratory passages. DO NOT have food or drink in the vicinity. Failure to comply may result in injury or death to personnel.

To prevent contamination, do not clean internal surfaces of any FAWPSS hose, valve, or fitting with cleaning solvent compound Skysol 100. Failure to comply may result in injury to personnel.

Compressed air source must not exceed 30 psi (207 kPa). When cleaning with compressed air, eye shields must be worn. Failure to comply may result in injury to personnel.

- a. Keep it clean – Dirt, grease, oil, and debris get in the way and may cover up a serious problem. Clean work area as needed. Use Skysol 100 to clean oil and grease from all exterior metal surfaces of equipment. Use a soap and water solution to clean dirt and debris from all exterior and interior surfaces, and rinse thoroughly with clean water.
- b. Bolts, nuts, and screws – Check them all for obvious looseness, missing, bent, or broken condition. Tighten loose hardware. Replace damaged hardware. Look for corrosion around bolt heads and if found, remove corrosion or replace hardware.
- c. Wiring harness, wires, and connectors – Look for cracked or broken wiring where present. If damaged wiring or loose connections are found, replace or repair damaged wiring.

END OF WORK PACKAGE

0019-3/4 blank

**UNIT MAINTENANCE
FOWARD AREA WATER POINT SUPPLY SYSTEM (FAWPSS)
PREVENTIVE MAINTENANCE CHECKS AND SERVICES (PMCS)
AND LUBRICATION INSTRUCTIONS**

INITIAL SETUP**Equipment Condition**

FAWPSS assembled for operation
(WP 0007 or WP 0008).

GENERAL

Unit PMCS applies to both FAWPSS Model LAB 9095 and FAWPSS Model M105. While performing unit PMCS, ensure components and assemblies are correctly installed. Incorrect installation may affect performance and cause equipment damage or failure.

When inspecting an item, ensure that all attaching/mounting hardware is properly secured. Tighten all loose hardware, and replace any cracked, broken, or missing parts during inspection.

Verify and correct any discrepancies recorded on DA Form 2404, Equipment Inspection and Maintenance Worksheet, while performing unit PMCS.

LUBRICATION

Lubrication of the FAWPSS is limited to required lubrication of the pump unit engine assembly. No lubrication is needed for all other FAWPSS components. Refer to References, WP 0044, for the applicable TM for the pump unit.

UNIT PMCS

Unit Maintenance of the FAWPSS is limited to performing a quarterly inspection. However, unit PMCS for the storage drums and pump unit will be performed IAW the applicable TMs. Refer to References, WP 0044.

END OF WORK PACKAGE

UNIT MAINTENANCE
FORWARD AREA WATER POINT SUPPLY SYSTEM (FAWPSS)
HOSE ASSEMBLY MAINTENANCE CLEANING, INSPECTION

INITIAL SETUP**Tools**

Tool kit, general mechanic's
 (WP 0046, Table 2, Item 1)

Materials/Parts

Brush (WP 0049, Item 2)
 Cleaning solvent (WP 0049, Item 3)
 Soap (WP 0049, Item 5)
 Cloth (WP 0049, Item 1)

Materials/Parts (Contd)

Two gaskets (WP 0032, Item 3 or 7)
 Two gaskets (WP 0032, Item 11)

Equipment Condition

Hose assembly removed from FAWPSS
 (WP 0010 for LAB 9095 or
 WP 0011 for M105).

CLEANING**WARNING**

To prevent contamination, dust cap and plug must be installed on hose ends prior to cleaning exterior surfaces of hose assembly. Never use solvents on inside surfaces of hose assembly. Failure to comply will result in contamination and possible injury to personnel.

NOTE

Maintenance of all hoses assemblies is performed the same way. 2 in. (51 mm) DIA x 10 ft (3 m) suction hose is shown.

1. Ensure dust cap (Figure 1, Item 4) and plug (Figure 1, Item 1) are installed securely on hose coupling halves (Figure 1, Item 3) and (Figure 1, Item 2).

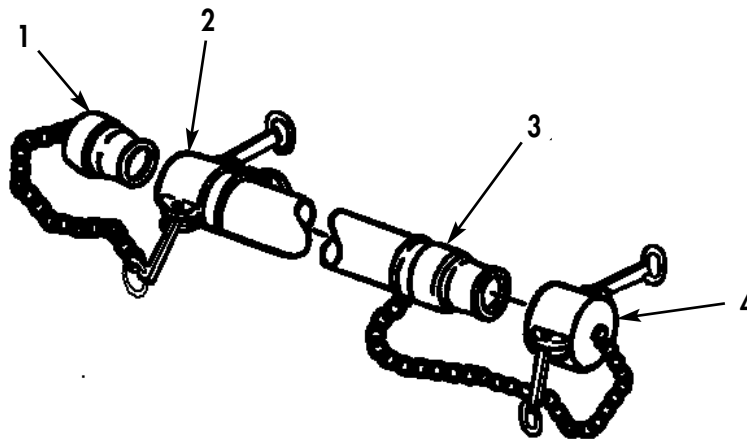

Figure 1. Hose Capped and Plugged.

HOSE ASSEMBLY MAINTENANCE CLEANING, INSPECTION (Contd)**CLEANING (Contd)****WARNING**

Cleaning solvent compound Skysol 100 mixture is combustible. Use mechanical ventilation whenever product is used in a confined space. DO NOT use or store near heat, sparks, flame, or other ignition sources. Keep container sealed when not in use.

Contact with Skysol 100 may cause skin irritation. Use chemical-resistant gloves. In case of skin contact, remove any contaminated clothing before reuse. Eye contact may cause irritation, tearing, or blurring of vision. Use face shield or goggles when eye contact may occur. In case of eye contact, flush eyes with large amounts of water for at least fifteen (15) minutes or until irritation subsides.

Inhalation may cause irritation to upper respiratory passages. DO NOT have food or drink in the vicinity. Failure to comply may result in injury or death to personnel.

To prevent contamination, do not clean internal surfaces of any FAWPSS hose, valve, or fitting with cleaning solvent compound Skysol 100. Failure to comply may result in injury to personnel.

CAUTION

Do not allow Skysol 100 to come in contact with FAWPSS hoses. Failure to comply will result in damage to rubber.

2. Using cleaning solvent, brush, and clean cloth, remove all build-up of oil and dirt from exterior of coupling halves (Figure 2, Item 2) and (Figure 2, Item 3) on hose (Figure 2, Item 1). Dry coupling halves with clean cloth.
3. Using soap and water, wash exterior surfaces of hose (Figure 2, Item 1) and coupling halves (Figure 2, Item 2) and (Figure 2, Item 9). Rinse exterior surfaces thoroughly.

WARNING

To prevent contamination, move hose assembly to a clean location prior to washing out inside of hose and couplings. Failure to comply may result in injury to personnel.

4. Remove dust cap (Figure 2, Item 4) and plug (Figure 2, Item 8) from coupling halves (Figure 2, Item 2) and (Figure 2, Item 9), and remove and discard gasket (Figure 2, Item 3) from cap (Figure 2, Item 4) and coupling half (Figure 2, Item 9).
5. Wash cap (Figure 2, Item 4), plug (Figure 2, Item 8), coupling halves (Figure 2, Item 2) and (Figure 2, Item 9), and inside of hose (Figure 2, Item 1) with soap and water solution. Rinse all items with clean water and dry with clean cloth.

END OF TASK

HOSE ASSEMBLY MAINTENANCE CLEANING, INSPECTION (Contd)**INSPECTION**

1. Inspect exterior of hose (Figure 2, Item 1) for cuts and punctures. If any cuts or punctures are found, discard hose assembly.
2. Inspect coupling half (Figure 2, Item 2) for cracks, distortion, and damage to mating surfaces that would result in leaks. If any cracks, distortion, or damaged mating surfaces are found, discard hose assembly.
3. Inspect coupling half (Figure 2, Item 9) for cracks, distortion, missing or excessively worn cam arms (Figure 2, Item 5), and damage to mating surfaces that would result in leaks. If cam arms (Figure 2, Item 5) are missing, worn, or damaged, or if any cracks, distortion, or damaged mating surfaces are found, discard hose assembly.
4. Inspect dust cap (Figure 2, Item 4), plug (Figure 2, Item 8), two retaining chains (Figure 2, Item 7), and four retaining rings (Figure 2, Item 6) for damage or if missing. Replace any damaged or missing item. Refer to WP 0032.
5. Install dust cap (Figure 2, Item 4) and new gasket (Figure 2, Item 3) on coupling half (Figure 2, Item 2), and install plug (Figure 2, Item 8) and new gasket (Figure 2, Item 3) on coupling half (Figure 2, Item 9).

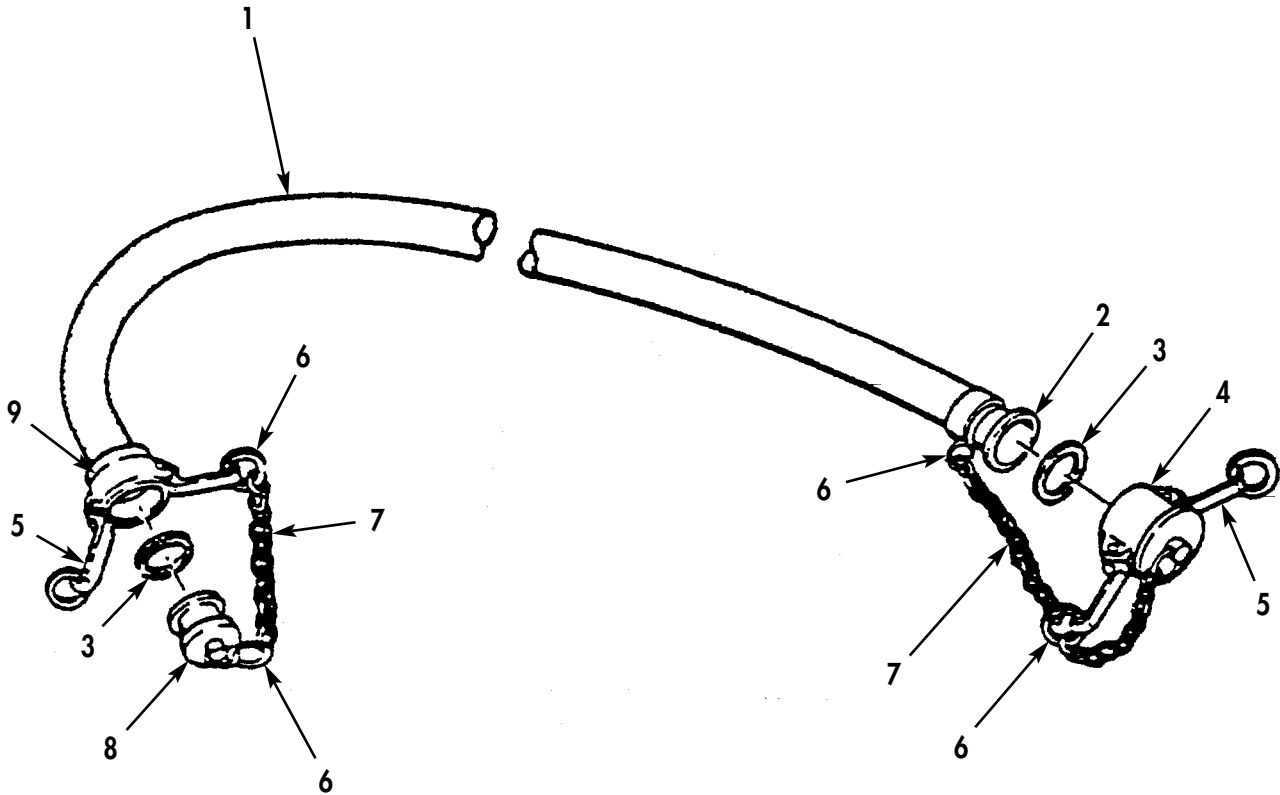

Figure 2. Hose Assembly.

END OF TASK

END OF WORK PACKAGE

UNIT MAINTENANCE
FRWARD AREA WATER POINT SUPPLY SYSTEM (FAWPSS)
BALL VALVE ASSEMBLY MAINTENANCE
CLEANING, DISASSEMBLY, INSPECTION, ASSEMBLY

INITIAL SETUP**Tools**

Tool kit, general mechanic's
(WP 0046, Table 2, Item 1)

Materials/Parts

Brush (WP 0049, Item 2)
Cleaning solvent (WP 0049, Item 3)
Soap (WP 0049, Item 5)
Cloth (WP 0049, Item 1)

Materials/Parts (Contd)

Sealing compound (WP 0049, Item 4)
Two gaskets (WP 0033, Item 5)

Equipment Condition

Ball valve assembly removed from FAWPSS
(WP 0010 or WP 0011).

CLEANING**WARNING**

To prevent contamination, dust cap and plug must be installed on ball valve prior to cleaning exterior surfaces of assembly. Never use solvents on inside surfaces of ball valve. Failure to comply will result in contamination and possible injury to personnel.

1. Ensure dust cap (Figure 1, Item 2) and plug (Figure 1, Item 4) are installed securely on ball valve coupling halves (Figure 1, Item 3) and (Figure 1, Item 1).

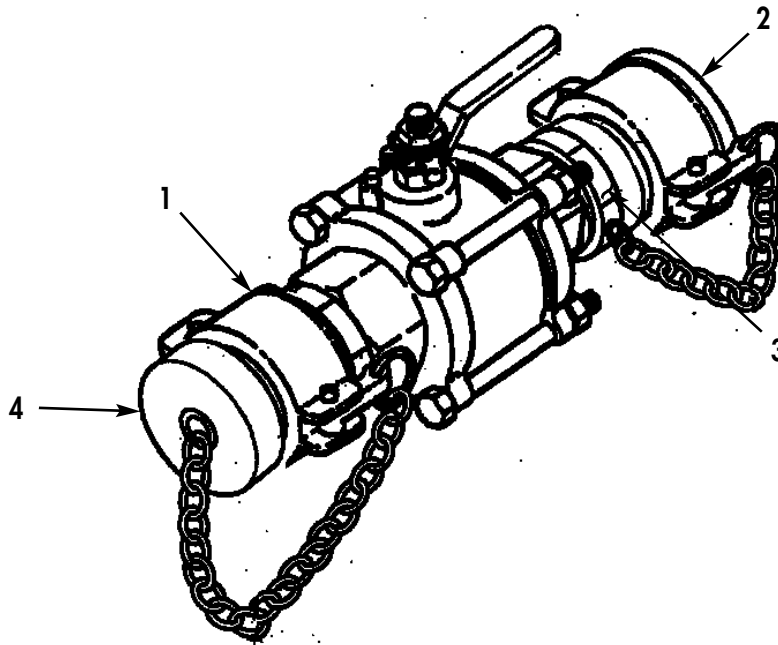

Figure 1. Ball Valve Capped and Plugged.

BALL VALVE ASSEMBLY MAINTENANCE (Contd)**CLEANING (Contd)****WARNING**

Cleaning solvent compound Skysol 100 mixture is combustible. Use mechanical ventilation whenever product is used in a confined space. DO NOT use or store near heat, sparks, flame, or other ignition sources. Keep container sealed when not in use.

Contact with Skysol 100 may cause skin irritation. Use chemical-resistant gloves. In case of skin contact, remove any contaminated clothing before reuse. Eye contact may cause irritation, tearing, or blurring of vision. Use face shield or goggles when eye contact may occur. In case of eye contact, flush eyes with large amounts of water for at least fifteen (15) minutes or until irritation subsides.

Inhalation may cause irritation to upper respiratory passages. DO NOT have food or drink in the vicinity. Failure to comply may result in injury or death to personnel.

2. Using cleaning solvent, brush, and clean cloth, remove all build-up of oil and dirt from exterior of coupling halves (Figure 2, Item 6) and (Figure 2, Item 3) and ball valve (Figure 2, Item 4). Dry ball valve assembly with clean cloth.
3. Using soap and water, wash exterior surfaces of ball valve (4) and coupling halves (6) and (3). Rinse exterior surfaces thoroughly.

WARNING

To prevent contamination, move ball valve assembly to a clean location prior to washing out inside of valve and coupling halves. Failure to comply may result in injury to personnel.

4. Remove dust cap (Figure 2, Item 7) and plug (Figure 2, Item 1) from coupling halves (Figure 2, Item 6) and (Figure 2, Item 3), and remove and discard gasket (Figure 2, Item 2) from cap (Figure 2, Item 7) and coupling half (Figure 2, Item 3).
5. Wash cap (Figure 2, Item 7), plug (Figure 2, Item 1), coupling halves (Figure 2, Item 6) and (Figure 2, Item 3), and inside of ball valve (Figure 2, Item 4) with soap and water solution. Rinse all items with clean water and dry with clean cloth.

END OF TASK**DISASSEMBLY**

1. Remove chain (Figure 2, Item 10) and two retaining rings (Figure 2, Item 8) from coupling halves (Figure 2, Item 6) and (Figure 2, Item 3) and dust cap (Figure 2, Item 7) and plug (Figure 2, Item 1).

CAUTION

Do not use a pipe wrench to remove coupling halves from ball valve. Use appropriate open end wrenches or damage to equipment may result.

NOTE

Note location of coupling halves for installation.

2. Remove coupling halves (Figure 2, Item 6) and (Figure 2, Item 3) from ball valve (Figure 2, Item 4).

END OF TASK

BALL VALVE ASSEMBLY MAINTENANCE (Contd)**INSPECTION****NOTE**

If ball valve will be replaced perform steps 3 through 5.

1. Inspect exterior of ball valve (Figure 2, Item 4) for cracks, distortion, and damaged or missing parts. If any damaged or missing parts are found, discard ball valve (Figure 2, Item 4).
2. Check for smooth operation of ball valve (Figure 2, Item 4). If lever (Figure 2, Item 5) cannot be turned or is excessively loose, discard ball valve (Figure 2, Item 4).
3. Inspect coupling half (Figure 2, Item 6) for cracks, distortion, and damage to mating surfaces that would result in leaks. If any cracks, distortion, or damaged mating surfaces are found, discard coupling half (Figure 2, Item 6).
4. Inspect coupling half (Figure 2, Item 3) for cracks, distortion, missing or excessively worn cam arms (9), and damage to mating surfaces that would result in leaks. If cam arms (Figure 2, Item 9) are missing, worn, or damaged, or if any cracks, distortion, or damaged mating surfaces are found, discard coupling half (Figure 2, Item 3).
5. Inspect dust cap (Figure 2, Item 7) and cam arms (Figure 2, Item 9), plug (Figure 2, Item 1), two retaining chains (Figure 2, Item 10), and four retaining rings (Figure 2, Item 8) for damage or if missing. Replace any damaged or missing item. Refer to WP 0033.

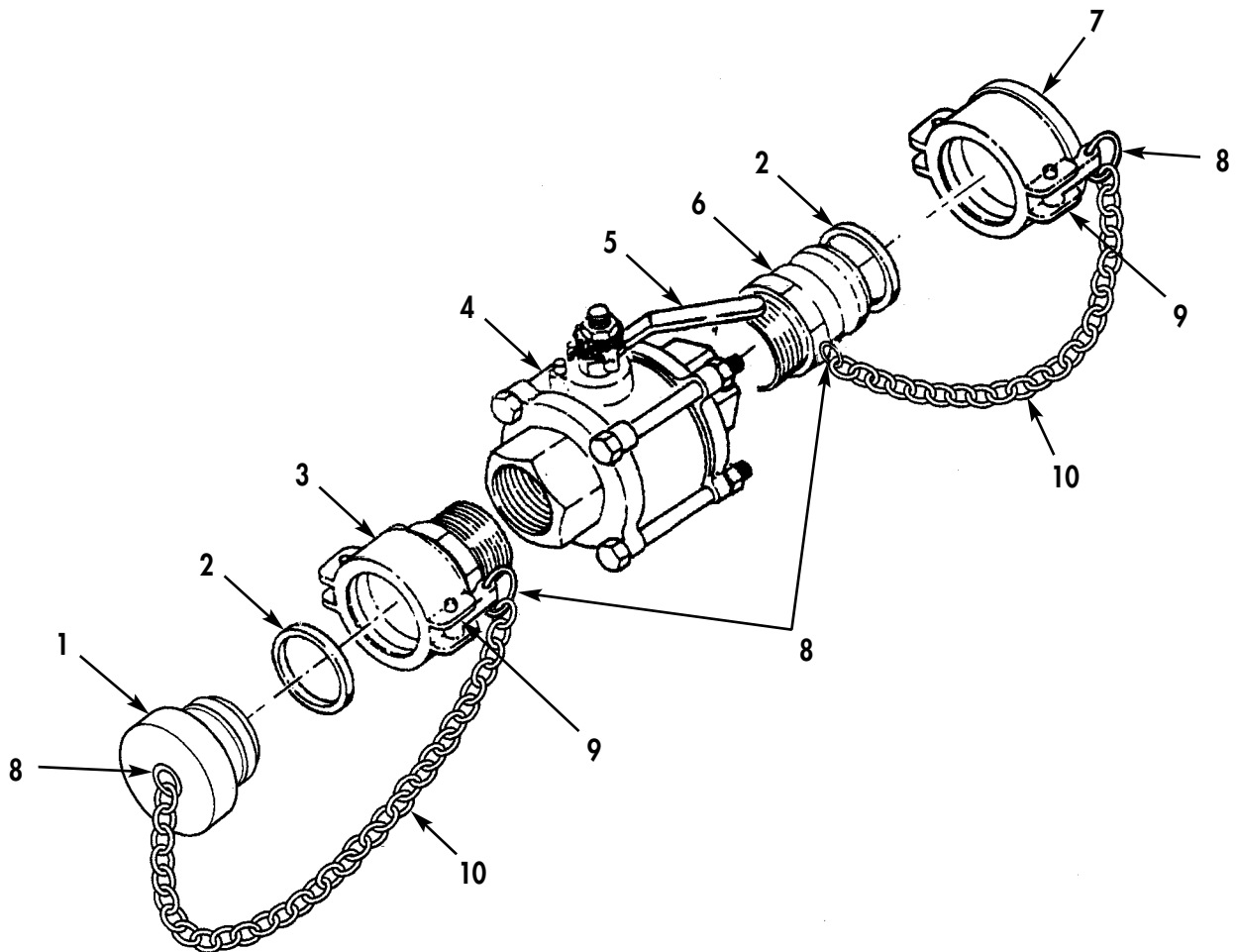

Figure 2. Ball Valve Couplings Removed.

END OF TASK

BALL VALVE ASSEMBLY MAINTENANCE (Contd)**ASSEMBLY****NOTE**

Ensure coupling halves are installed as noted during disassembly.

1. Apply sealing compound to male pipe threads on coupling halves (Figure 3, Item 5) and (Figure 3, Item 3), and install coupling halves (Figure 3, Item 5) and (Figure 3, Item 3) on ball valve (Figure 3, Item 4). Remove any excess sealing compound with cloth.
2. Install two chains (Figure 3, Item 8) on coupling halves (Figure 3, Item 5) and (Figure 3, Item 3), dust cap (Figure 3, Item 6), and plug (Figure 3, Item 1) with four retaining rings (Figure 3, Item 7).
3. Install dust cap (Figure 3, Item 6) and new gasket (Figure 3, Item 2) on coupling half (Figure 3, Item 5), and install plug (Figure 3, Item 1) and new gasket (Figure 3, Item 2) on coupling half (Figure 3, Item 3).
4. Connect ball valve (Figure 3, Item 4) to FAWPSS and check for leaks. Refer to WP 0005.

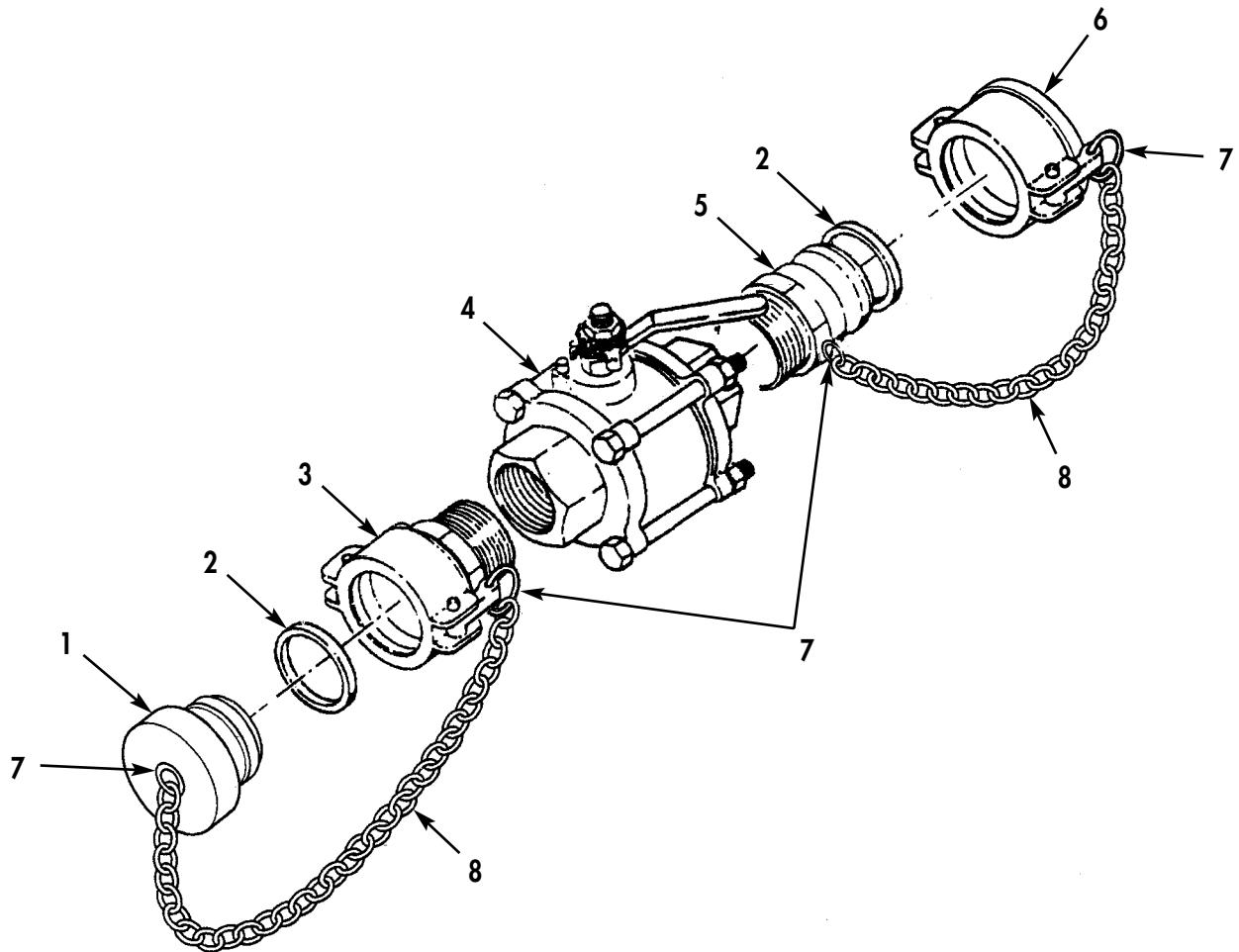

Figure 3. Ball Valve Coupling.

END OF TASK

END OF WORK PACKAGE

**UNIT MAINTENANCE
FORWARD AREA WATER POINT SUPPLY SYSTEM (FAWPSS)
NOZZLE ASSEMBLY MAINTENANCE
DISASSEMBLY, CLEANING, INSPECTION, ASSEMBLY**

INITIAL SETUP**Tools**

Tool kit, general mechanic's
(WP 0046, Table 2, Item 1)

Materials/Parts

Brush (WP 0049, Item 2)
Cleaning solvent (WP 0049, Item 3)
Soap (WP 0049, Item 5)

Materials/Parts (Contd)

Cloth (WP 0049, Item 1)
Antiseize tape (WP 0049, Item 6)
Gasket (WP 0034, Item 4)

Equipment Condition

Nozzle assembly removed from FAWPSS
(WP 0010 or WP 0011).

CLEANING**WARNING**

To prevent contamination, dust cap and plug must be installed on nozzle assembly prior to cleaning exterior surfaces of assembly. Never use solvents on inside surfaces of nozzle assembly. Failure to comply may result in contamination and possible injury to personnel.

1. Ensure dust cap (Figure 1, Item 3) and plug (Figure 1, Item 4) are installed securely on nozzle spout (Figure 1, Item 2) and coupling half (Figure 1, Item 1).

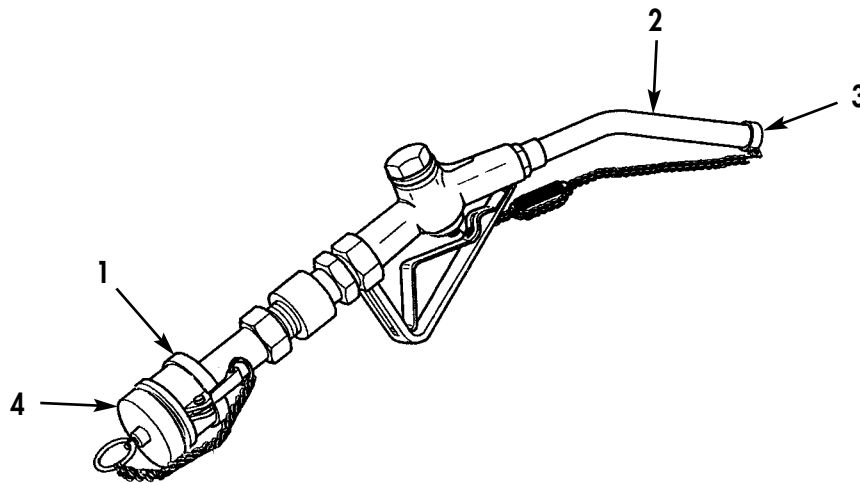

Figure 1. Nozzle Capped and Plugged.

NOZZLE ASSEMBLY MAINTENANCE (Contd)**CLEANING (Contd)****WARNING**

Cleaning solvent compound Skysol 100 mixture is combustible. Use mechanical ventilation whenever product is used in a confined space. DO NOT use or store near heat, sparks, flame, or other ignition sources. Keep container sealed when not in use.

Contact with Skysol 100 may cause skin irritation. Use chemical-resistant gloves. In case of skin contact, remove any contaminated clothing before reuse. Eye contact may cause irritation, tearing, or blurring of vision. Use face shield or goggles when eye contact may occur. In case of eye contact, flush eyes with large amounts of water for at least fifteen (15) minutes or until irritation subsides.

Inhalation may cause irritation to upper respiratory passages. DO NOT have food or drink in the vicinity. Failure to comply may result in injury or death to personnel.

2. Using cleaning solvent, brush, and clean cloth, remove all build-up of oil and dirt from nozzle assembly (Figure 2, Item 2), swivel joint (Figure 2, Item 4), and coupling half (Figure 2, Item 5). Dry parts with clean cloth.
3. Using soap and water, wash exterior surfaces of nozzle assembly (Figure 2, Item 2), swivel joint (Figure 2, Item 4), and coupling half (Figure 2, Item 5). Rinse exterior surfaces thoroughly with water.

WARNING

To prevent contamination, move nozzle assembly to a clean location prior to washing out inside of nozzle and coupling half. Failure to comply may result in injury to personnel.

4. Remove dust cap (Figure 2, Item 1) and plug (Figure 2, Item 7) from nozzle spout (Figure 2, Item 16) and coupling half (Figure 2, Item 5), and remove and discard gasket (Figure 2, Item 6) from coupling half (Figure 2, Item 5).
5. Wash dust cap (Figure 2, Item 1), plug (Figure 2, Item 7), coupling half (Figure 2, Item 5), swivel joint (Figure 2, Item 4), and inside of nozzle assembly (Figure 2, Item 2) with soap and water solution. Rinse all items with clean water and dry with clean cloth.

END OF TASK**DISASSEMBLY**

1. Remove chain (Figure 2, Item 9) and two retaining rings (Figure 2, Item 8) from coupling half (Figure 2, Item 5) and plug (Figure 2, Item 7).

CAUTION

Do not use a pipe wrench to remove coupling half and swivel joint from nozzle assembly. Use appropriate open end wrenches or damage to equipment may result.

2. Remove coupling half (Figure 2, Item 5) and swivel joint (Figure 2, Item 4) from nozzle assembly (Figure 2, Item 2).
3. Remove dust cap (Figure 2, Item 1) assembly from nozzle assembly (Figure 2, Item 2). Do not disassemble at this time.

END OF TASK

NOZZLE ASSEMBLY MAINTENANCE (Contd)

INSPECTION

NOTE

If nozzle will be replaced perform steps 3 through 5.

1. Inspect exterior of nozzle assembly (Figure 2, Item 2) for cracks, distortion, and damaged or missing parts. If any damage or missing parts are found, discard nozzle assembly (Figure 2, Item 2).
2. Check for smooth operation of nozzle lever (Figure 2, Item 3). If lever (Figure 2, Item 3) or valve stem (Figure 2, Item 11) do not return when pulled, discard nozzle assembly (Figure 2, Item 2).
3. Inspect swivel joint (Figure 2, Item 4) for cracks, distortion, and excessive looseness that would result in leaks. If any cracks, distortion, or excessive looseness is found, discard swivel joint (Figure 2, Item 4).
4. Inspect coupling half (Figure 2, Item 5) for cracks, distortion, missing or excessively worn cam arms (Figure 2, Item 10), and damage to mating surfaces that would result in leaks. If cam arms (Figure 2, Item 10) are missing, worn, or damaged, or if any cracks, distortion, or damaged mating surfaces are found, discard coupling half (Figure 2, Item 5).
5. Inspect dust cap (Figure 2, Item 1), two links (Figure 2, Item 14), chains (Figure 2, Item 12), draw bars (Figure 2, Item 13), and compression spring (Figure 2, Item 15) for damage or if missing. Remove and replace any damaged or missing item. Refer to WP 0034.

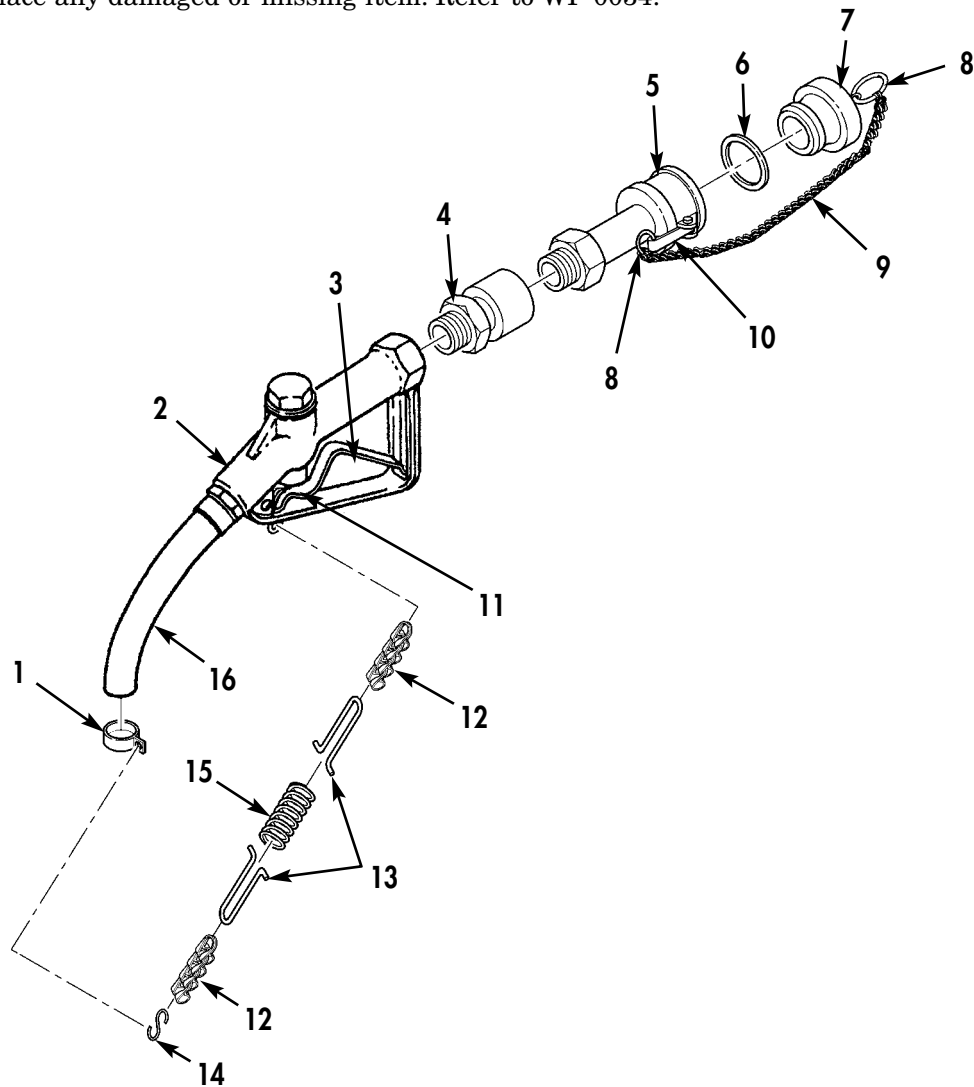

Figure 2. Nozzle Cap, Swivel, and Coupling.

END OF TASK

NOZZLE ASSEMBLY MAINTENANCE (Contd)**ASSEMBLY**

1. Apply sealing compound to male pipe threads on swivel joint (Figure 3, Item 2) and coupling half (Figure 3, Item 3), and install swivel joint (Figure 3, Item 2) and coupling half (Figure 3, Item 3) on nozzle assembly (Figure 3, Item 1). Remove any excess sealing compound with cloth.
2. Install chain (Figure 3, Item 7) on coupling half (Figure 3, Item 3) and plug (Figure 3, Item 5) with two retaining rings (Figure 3, Item 6), and install plug (Figure 3, Item 5) and new gasket (Figure 3, Item 4) on coupling half (3).
3. Install dust cap (Figure 3, Item 9) on nozzle assembly (Figure 3, Item 1), and secure dust cap (Figure 3, Item 9) on nozzle spout (Figure 3, Item 8).
4. Connect nozzle assembly to FAWPSS. Refer to WP 0007 or WP 0008. Operate nozzle assembly and check for leaks. Refer to WP 0005.

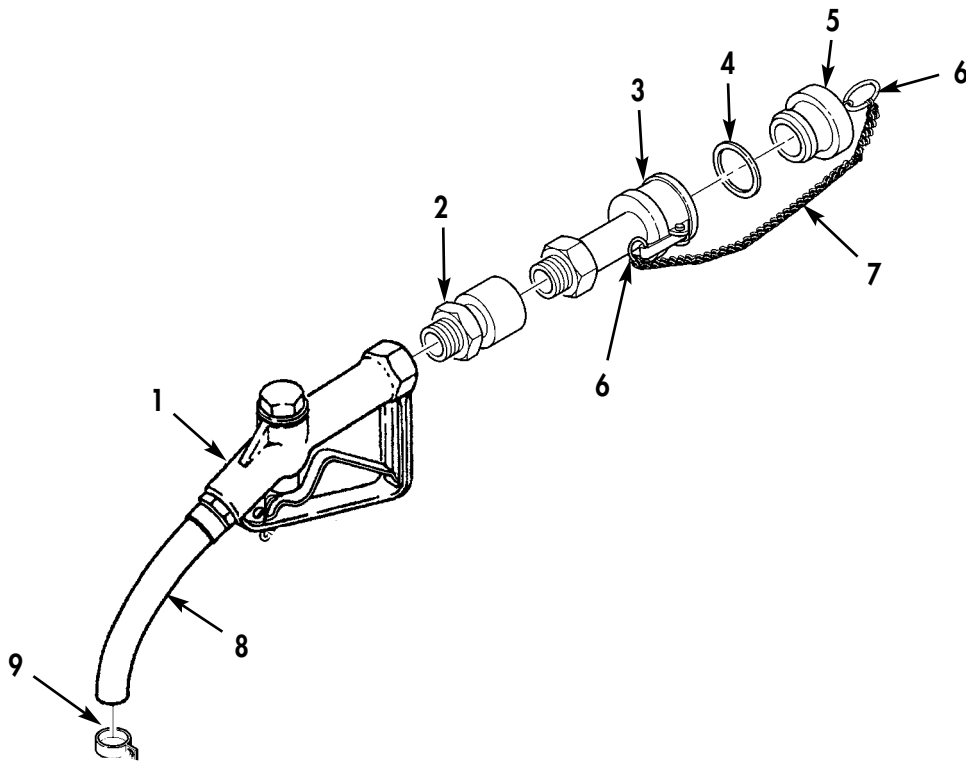

Figure 3. Nozzle Assembly.

END OF TASK

END OF WORK PACKAGE

UNIT MAINTENANCE
FORWARD AREA WATER POINT SUPPLY SYSTEM (FAWPSS)
NOZZLE STAND ASSEMBLY MAINTENANCE
DISASSEMBLY, CLEANING, INSPECTION, ASSEMBLY

INITIAL SETUP**Tools**

Tool kit, general mechanic's
 (WP 0046, Table 2, Item 1)

Materials/Parts

Brush (WP 0049, Item 2)
 Cleaning solvent (WP 0049, Item 3)
 Cloth (WP 0049, Item 1)

Materials/Parts (Contd)

Two cotter pins (WP0035, Item 3)

Equipment Condition

Stand assembly removed from FAWPSS
 installation (WP 0010 or WP 0011).

DISASSEMBLY

1. Open and remove three chain hooks (Figure 1, Item 1) and chains (Figure 1, Item 6) from eyes (Figure 1, Item 7) on two clevis legs (Figure 1, Item 2) and pivot leg (Figure 1, Item 5).
2. Remove two cotter pins (Figure 1, Item 3), straight pins (Figure 1, Item 4) and clevis legs (Figure 1, Item 2) from pivot leg (Figure 1, Item 5). Discard cotter pins (Figure 1, Item 3).

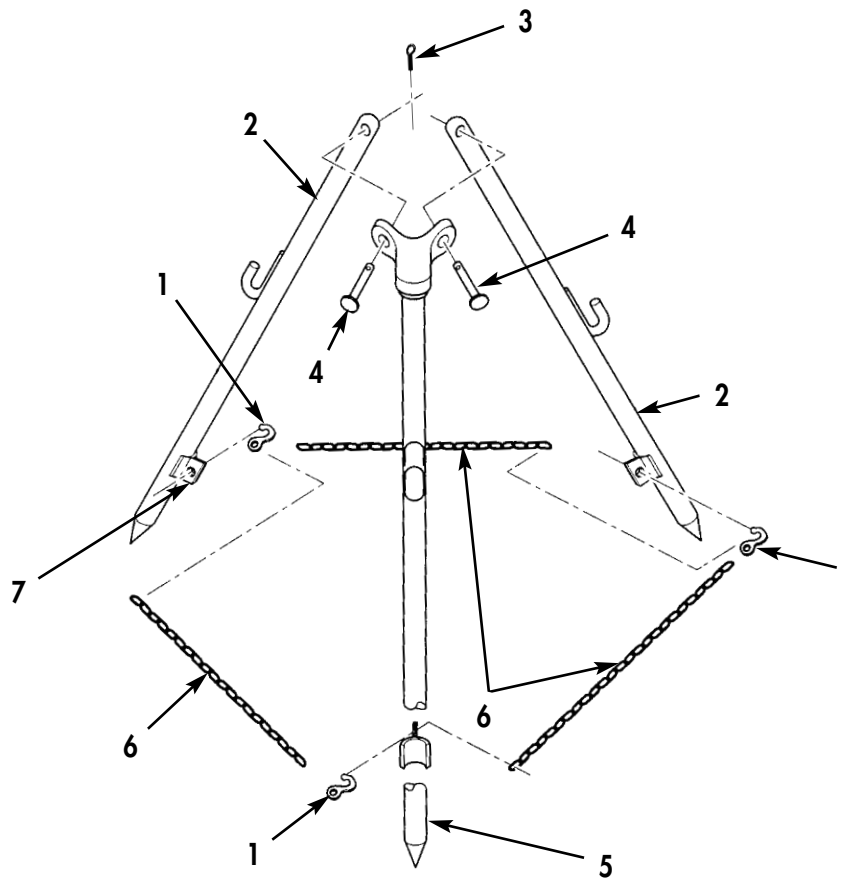

Figure 1. Disassembly of Nozzle Stand.

END OF TASK

NOZZLE STAND ASSEMBLY MAINTENANCE (Contd)**CLEANING****WARNING**

Cleaning solvent compound Skysol 100 mixture is combustible. Use mechanical ventilation whenever product is used in a confined space. DO NOT use or store near heat, sparks, flame, or other ignition sources. Keep container sealed when not in use.

Contact with Skysol 100 may cause skin irritation. Use chemical-resistant gloves. In case of skin contact, remove any contaminated clothing before reuse. Eye contact may cause irritation, tearing, or blurring of vision. Use face shield or goggles when eye contact may occur. In case of eye contact, flush eyes with large amounts of water for at least fifteen (15) minutes or until irritation subsides.

Inhalation may cause irritation to upper respiratory passages. DO NOT have food or drink in the vicinity. Failure to comply may result in injury or death to personnel.

Using cleaning solvent, brush, and clean cloth, remove all build-up of oil and dirt from all nozzle stand assembly parts. Dry parts with clean cloth.

END OF TASK**INSPECTION**

Inspect all parts for cracks, corrosion, and if bent or missing. Remove corrosion as necessary. Refer to WP 0028. Replace all damaged or missing parts. Refer to WP 0035.

END OF TASK**ASSEMBLY**

1. Install two clevis legs (Figure 2, Item 2) on pivot leg (Figure 2, Item 5) with two straight pins (Figure 2, Item 4) and new cotter pins (Figure 2, Item 3).
2. Install three chains (Figure 2, Item 6) on eyes (Figure 2, Item 7) on two clevis legs (Figure 2, Item 2) and pivot leg (Figure 2, Item 5) with three chain hooks (Figure 2, Item 1). Secure chains (Figure 2, Item 6) by closing three chain hooks (Figure 2, Item 1).

NOZZLE STAND ASSEMBLY MAINTENANCE (Contd)

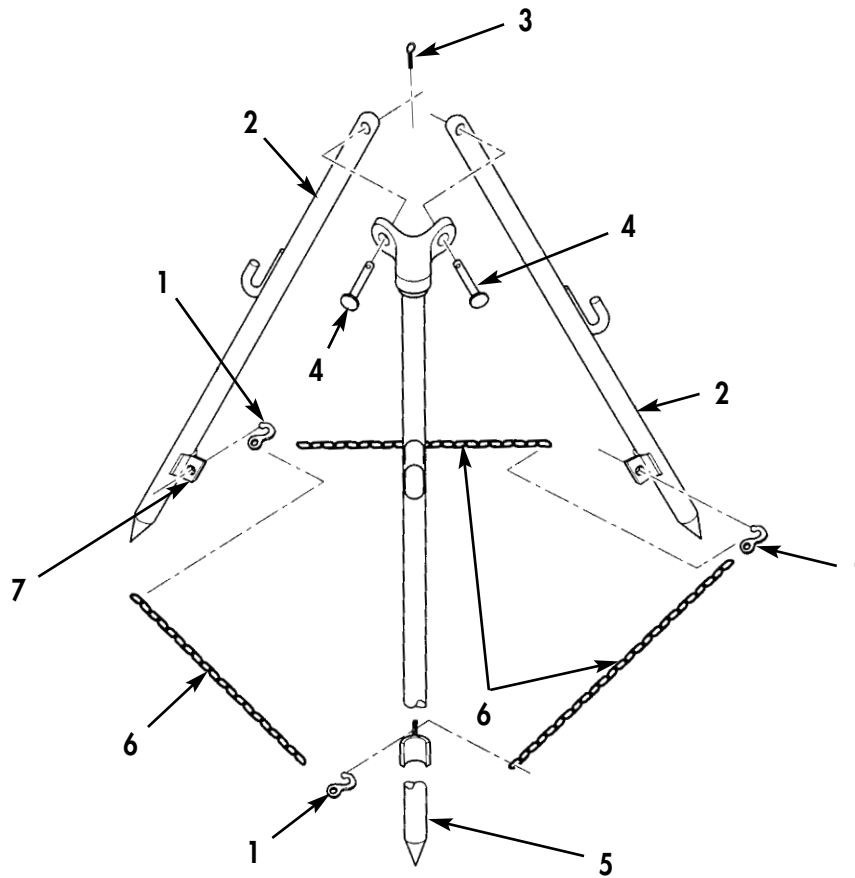

Figure 2. Assembly of Nozzle Stand.

END OF TASK

END OF WORK PACKAGE

UNIT MAINTENANCE
FORWARD AREA WATER POINT SUPPLY SYSTEM (FAWPSS)
TOWING AND LIFTING YOKE MAINTENANCE
DISASSEMBLY, CLEANING, INSPECTION, ASSEMBLY
EFFECTIVITY NOTICE
 Model LAB 9095

INITIAL SETUP**Tools**

Tool kit, general mechanic's
 (WP 0046, Table 2, Item 1)

Materials/Parts (Contd)

Two locknuts (WP 0036, Item 9)
 Two locknuts (WP 0036, Item 11)

Materials/Parts

Brush (WP 0049, Item 2)
 Cleaning solvent (WP 0049, Item 3)
 Cloth (WP 0049, Item 1)

Equipment Condition

Yoke removed from FAWPSS drum
 (WP 0010 or WP 0011).

DISASSEMBLY

1. Open and disconnect two chain hooks (Figure 1, Item 7) from eyes (Figure 1, Item 6) on two connecting legs (Figure 1, Item 1), and remove two clevis pin assemblies (Figure 1, Item 3).
2. Remove two locknuts (Figure 1, Item 5) and screws (Figure 1, Item 2) from two braces (Figure 1, Item 4). Discard locknuts (Figure 1, Item 5).

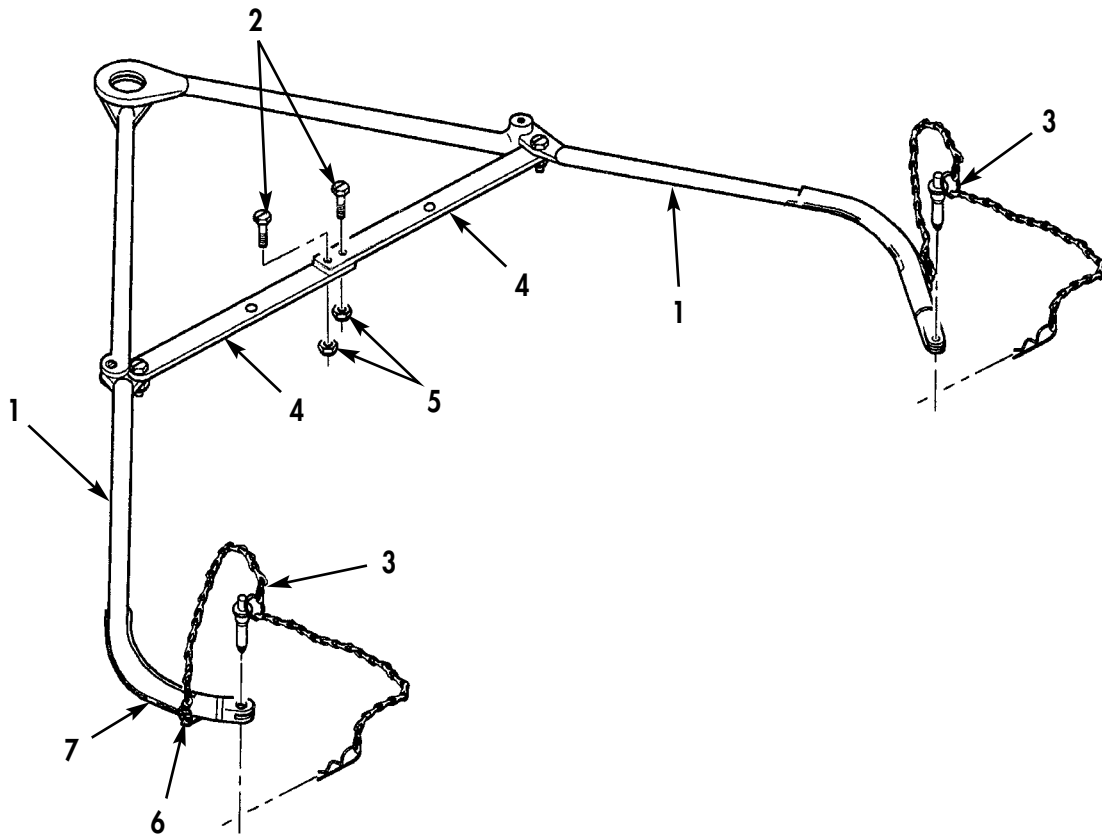

Figure 1. Towing and Lifting Yoke Clevis Pins.

TOWING AND LIFTING YOKE MAINTENANCE (Contd)**DISASSEMBLY (Contd)**

3. Remove two locknuts (Figure 2, Item 8), screws (Figure 2, Item 5), and braces (Figure 2, Item 9) from two connecting legs (Figure 2, Item 6). Discard locknuts (Figure 2, Item 8).
4. Remove two setscrews (Figure 2, item 4), straight pins (Figure 2, Item 3), and connecting legs (Figure 2, Item 6), from two upper legs (Figure 2, Item 1).

CLEANING**WARNING**

Cleaning solvent compound Skysol 100 mixture is combustible. Use mechanical ventilation whenever product is used in a confined space. DO NOT use or store near heat, sparks, flame, or other ignition sources. Keep container sealed when not in use.

Contact with Skysol 100 may cause skin irritation. Use chemical-resistant gloves. In case of skin contact, remove any contaminated clothing before reuse. Eye contact may cause irritation, tearing, or blurring of vision. Use face shield or goggles when eye contact may occur. In case of eye contact, flush eyes with large amounts of water for at least fifteen (15) minutes or until irritation subsides.

Inhalation may cause irritation to upper respiratory passages. DO NOT have food or drink in the vicinity. Failure to comply may result in injury or death to personnel.

Using cleaning solvent, brush, and clean cloth, remove all build-up of oil and dirt from all towing and lifting yoke parts. Dry parts with clean cloth.

END OF TASK**INSPECTION**

Inspect all parts for cracks, corrosion, and if bent or missing. Remove corrosion as necessary. Refer to WP 0028. Replace all damaged or missing parts. Refer to WP 0036.

END OF TASK**ASSEMBLY**

1. Install two connecting legs (Figure 2, Item 6) on upper legs (Figure 2, Item 1) with two straight pins (Figure 2, Item 3) and setscrews (Figure 2, Item 4).
2. Install two braces (Figure 2, Item 9) on two connecting legs (Figure 2, Item 1) with two screws (Figure 2, Item 5) and new locknuts (Figure 2, Item 8).

NOTE

If yoke will be folded for transport do not connect braces when installing mounting screws. If yoke will be unfolded for use, connect braces when installing mounting screws.

3. Install two mounting screws (Figure 2, Item 2) on two braces (Figure 2, Item 9) with new locknuts (Figure 2, Item 10).
4. Install two clevis pin assemblies (Figure 2, Item 7) on two connecting legs (Figure 2, Item 6) by connecting chain hook (Figure 2, Item 12) to eye (Figure 2, Item 11) on each connecting leg (Figure 2, Item 6). Secure two clevis pin assemblies (Figure 2, Item 7) by closing two chain hooks (Figure 2, Item 12).

TOWING AND LIFTING YOKE MAINTENANCE (Contd)

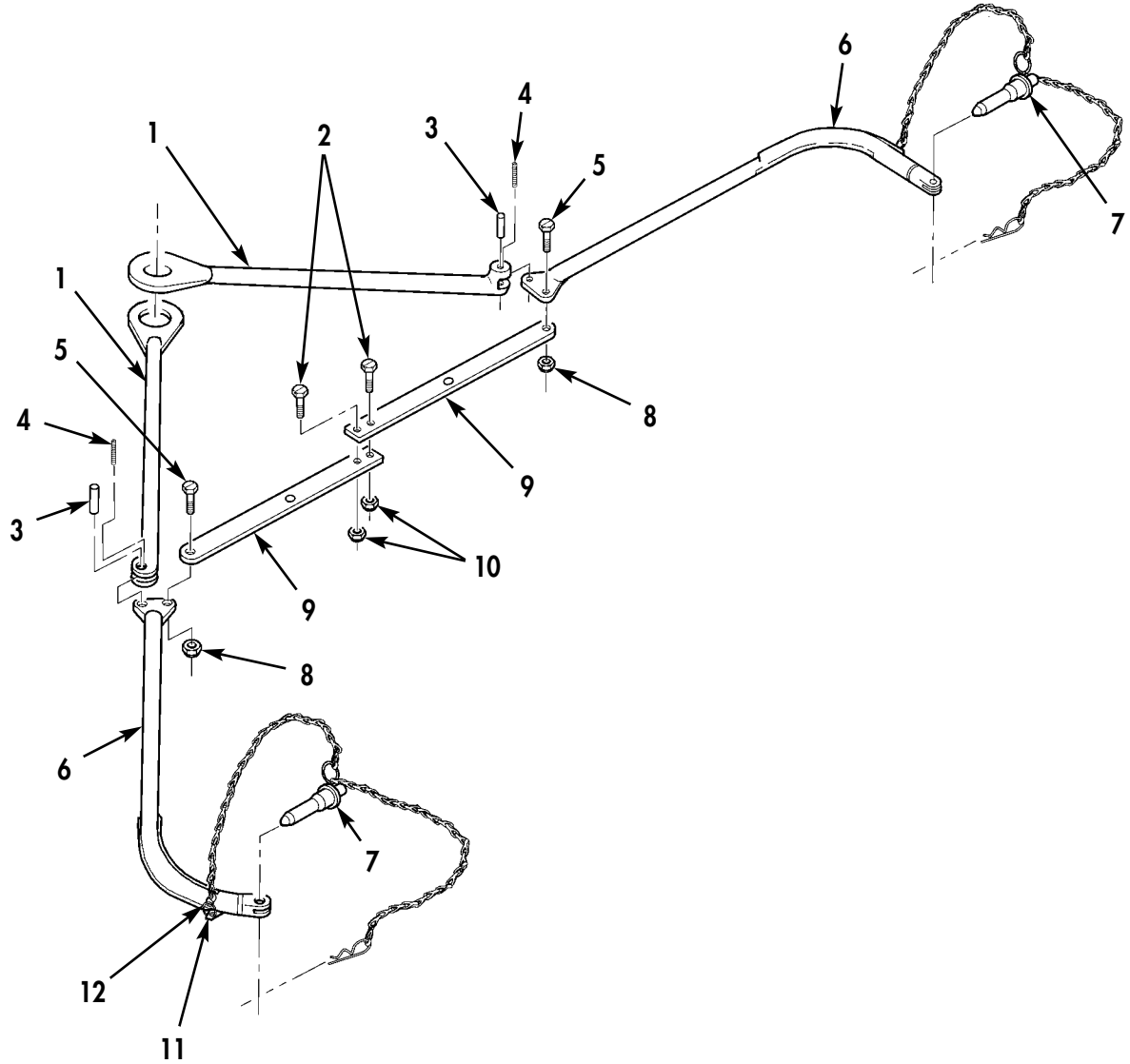

Figure 2. Towing and Lifting Yoke Assembly.

END OF TASK

END OF WORK PACKAGE

**UNIT MAINTENANCE
FORWARD AREA WATER POINT SUPPLY SYSTEM (FAWPSS)
MISCELLANEOUS FITTINGS MAINTENANCE
CLEANING, INSPECTION, INSTALLATION**

INITIAL SETUP**Tools**

Tool kit, general mechanic's
(WP 0046, Table 2, Item 1)
Wrench, pipe (WP 0046, Table 2, Item 2)

Materials/Parts (Contd)

Soap (WP 0049, Item 5)
Cloth (WP 0049, Item 1)
Antiseize tape (WP 0049, Item 6)

Materials/Parts

Brush (WP 0049, Item 2)
Cleaning solvent (WP 0049, Item 3)

Equipment Condition

Fitting removed from FAWPSS
(WP 0010 for LAB 9095 or WP 0011 for M105).

CLEANING**WARNING**

Cleaning solvent compound Skysol 100 mixture is combustible. Use mechanical ventilation whenever product is used in a confined space. **DO NOT** use or store near heat, sparks, flame, or other ignition sources. Keep container sealed when not in use.

Contact with Skysol 100 may cause skin irritation. Use chemical-resistant gloves. In case of skin contact, remove any contaminated clothing before reuse. Eye contact may cause irritation, tearing, or blurring of vision. Use face shield or goggles when eye contact may occur. In case of eye contact, flush eyes with large amounts of water for at least fifteen (15) minutes or until irritation subsides.

Inhalation may cause irritation to upper respiratory passages. **DO NOT** have food or drink in the vicinity. Failure to comply may result in injury or death to personnel.

Never use solvents to clean inside surfaces of FAWPSS fittings; use a soap and water solution only. Failure to comply will result in contamination and possible injury to personnel.

MISCELLANEOUS FITTINGS MAINTENANCE (Contd)

CLEANING (Contd)

NOTE

The FAWPSS is furnished with a number of miscellaneous fittings. Fittings such as quick-disconnect couplings and pipes or elbows having national pipe threads are used to make connections between various major components such as hoses, valves, nozzles, drums, and the pump unit. All miscellaneous fittings covered in this work package are COEI for FAWPSS Model LAB 9095 and FAWPSS Model M105.

1. Using cleaning solvent, brush, and clean cloth, remove all build-up of oil and dirt from exterior surface of reducer (Figure 1, Item 1), reducer (Figure 2, Item 1), Y-fitting (Figure 3, Item 1), swivel (Figure 4, item 1), male adapter (Figure 5, item 1), male coupling half (Figure 6, Item 1), male coupling half (Figure 7, Item 1), female coupling half (Figure 8, Item 1), female coupling half (Figure 9, Item 1), plug (Figure 10, Item 1), plug (Figure 11, Item 1), cap (Figure 12, Item 1), retaining ring (Figure 13, Item 1), and retaining chain (Figure 14, Item 1). Dry parts with clean cloth.
2. Using soap and water solution, wash inner and outer surfaces of each fitting. Rinse all items with clean water and dry with clean cloth.

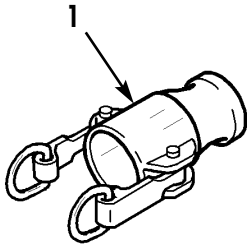

Figure 1. Reducer, 2 in.

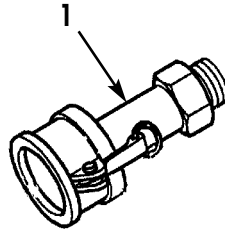

Figure 2. Reducer, 1.5 in.

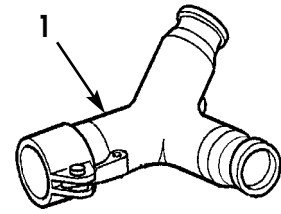

Figure 3. Y-Fitting.

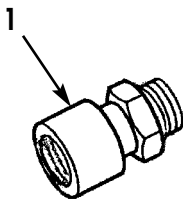

Figure 4. Swivel.

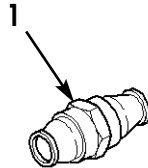

Figure 5. Adapter.

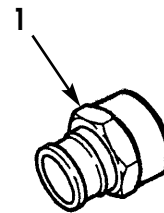

Figure 6. Male Coupling.

MISCELLANEOUS FITTINGS MAINTENANCE (Contd)

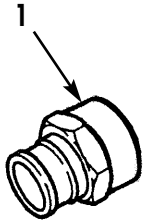

Figure 7. Male Coupling.

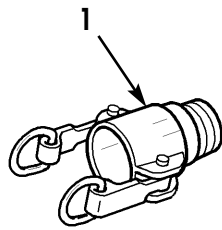

Figure 8. Female Coupling.

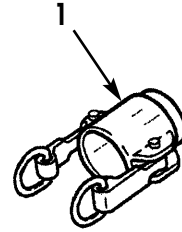

Figure 9. Female Coupling.

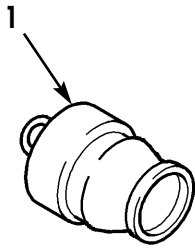

Figure 10. Plug, 2 in.

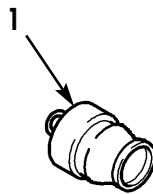

Figure 11. Plug, 1.5 in.

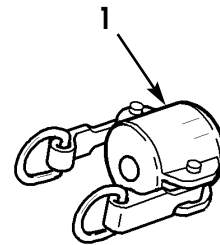

Figure 12. Cap, 2 in.

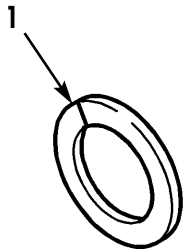

Figure 13. Retaining Ring.

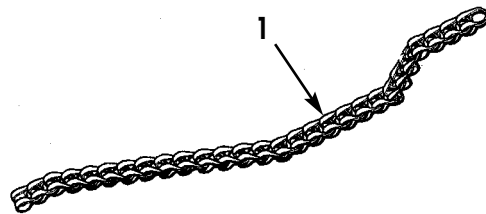

Figure 14. Retaining Chain.

END OF TASK

INSPECTION

Inspect all fittings for cracks, deformation, corrosion, and missing parts. Remove corrosion as necessary. Refer to WP 0028. Replace all damaged or missing parts. Refer to WP 0037.

END OF TASK

MISCELLANEOUS FITTINGS MAINTENANCE (Contd)

INSTALLATION

NOTE

Installation of all FAWPSS fittings having national pipe threads is performed the same way. To prevent leaks, always apply anti-seize tape to male pipe threads.

Connecting cam-locking, quick-disconnect style couplings is performed the same way. To prevent leaks, always use a gasket between two fittings.

The FAWPSS pump unit may require the installation of pipe fittings and cam-locking quick-disconnect couplings on the pump suction and discharge ports when received new for the first time. If the pump unit does not have these fittings installed when unpacked, perform the following procedure.

3. Apply antiseize tape to male pipe threads only, and install 2 in. (51 mm) DIA street elbow (Figure 15, Item 4), 2 in. (51 mm) long pipe nipple (Figure 15, item 3), and male coupling (Figure 15, Item 2) on discharge port (Figure 15, Item 1) of pump (Figure 15, Item 9).
4. Apply antiseize tape to male pipe threads only, and install 2 in. (51 mm) DIA x 6 in. (152 mm) long pipe nipple (Figure 15, Item 6), 90-degree elbow (Figure 15, Item 7) and female coupling (Figure 15, Item 8) on suction port (Figure 15, Item 5) of pump (Figure 16, Item 9).

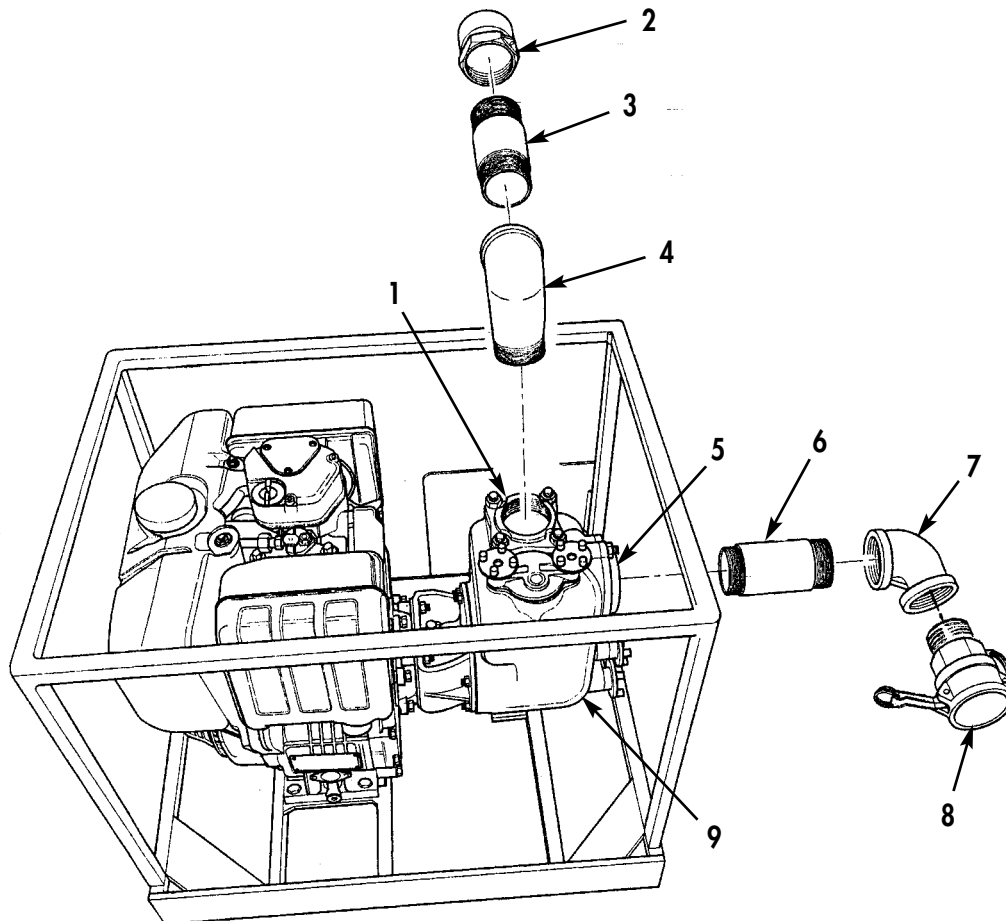

Figure 15. Pump Fittings, FAWPSS Model M105.

END OF TASK

END OF WORK PACKAGE

**UNIT MAINTENANCE
FORWARD AREA WATER POINT SUPPLY SYSTEM (FAWPSS)
TIEDOWN ASSEMBLIES MAINTENANCE
CLEANING, INSPECTION
EFFECTIVITY NOTICE
Model LAB 9095**

INITIAL SETUP**Tools**

Tool kit, general mechanic's
(WP 0046, Table 2, Item 1)

Materials/Parts (Contd)

Cloth (WP 0049, Item 1)
Tie straps (WP 0049, Item 7)

Materials/Parts

Brush (WP 0049, Item 2)
Cleaning solvent (WP 0049, Item 3)
Soap (WP 0049, Item 5)

Equipment Condition

Tiedowns removed from FAWPSS (WP 0009).

CLEANING**WARNING**

Cleaning solvent compound Skysol 100 mixture is combustible. Use mechanical ventilation whenever product is used in a confined space. DO NOT use or store near heat, sparks, flame, or other ignition sources. Keep container sealed when not in use.

Contact with Skysol 100 may cause skin irritation. Use chemical-resistant gloves. In case of skin contact, remove any contaminated clothing before reuse. Eye contact may cause irritation, tearing, or blurring of vision. Use face shield or goggles when eye contact may occur. In case of eye contact, flush eyes with large amounts of water for at least fifteen (15) minutes or until irritation subsides.

Inhalation may cause irritation to upper respiratory passages. DO NOT have food or drink in the vicinity. Failure to comply may result in injury or death to personnel.

NOTE

The tiedown assemblies covered in this work package are those supplied for FAWPSS Model M105 only.

TIEDOWN ASSEMBLIES MAINTENANCE (Contd)**CLEANING (Contd)**

1. Using cleaning solvent, brush, and clean cloth, remove all build-up of oil and dirt from each chain tiedown assembly (Figure 1, Item 4) and each tiedown strap assembly (Figure 2, Item 3). Dry tiedown chain assemblies (Figure 1, Item 4) and tiedown strap assemblies (Figure 2, Item 3) with clean cloth.

CAUTION

Ensure fabric straps are dry prior to rolling them up for storage. Failure to comply may result in mold formation and damage to equipment.

2. Using soap and water, wash each chain tiedown assembly (Figure 1, Item 4) and each tiedown strap assembly (Figure 2, Item 3). Rinse exterior surfaces thoroughly and allow to air dry.
3. Wash each protective sleeve (Figure 3, Item 1) in soap and water solution. Rinse with water and allow to air dry.

END OF TASK**INSPECTION****NOTE**

The tiedown kit must contain a total of twelve chain tiedown assemblies, ten tiedown strap assemblies, and sixteen protective sleeves to be complete. Any damaged or missing items must be replaced.

1. Inspect each chain tiedown assembly (Figure 1, Item 4) for cracks and damage or missing parts. Check chain (Figure 1, Item 1), two hook ends (Figure 1, Item 5), tensioner assembly (Figure 1, Item 7), shock mitigation block (Figure 1, Item 6), adjustment wheel (Figure 1, Item 3), hook (Figure 1, Item 8), and tensioner lever (Figure 1, Item 2) for damage. Discard chain tiedown assembly (Figure 1, Item 4) if any cracks, damage or missing parts are found.
2. Inspect each tiedown strap assembly (Figure 2, Item 3) for tares in two straps (Figure 2, Item 4), damage to hook ends (Figure 2, Item 1), and functionality of ratchet (Figure 2, Item 2). If any tears, damage, or missing parts are found, discard tiedown strap assembly (Figure 2, Item 3).
3. Inspect each protective sleeve (Figure 3, Item 1) for cuts and rips. Replace any protective sleeve (Figure 3, Item 1) found to be cut or ripped.

TIEDOWN ASSEMBLIES MAINTENANCE (Contd)

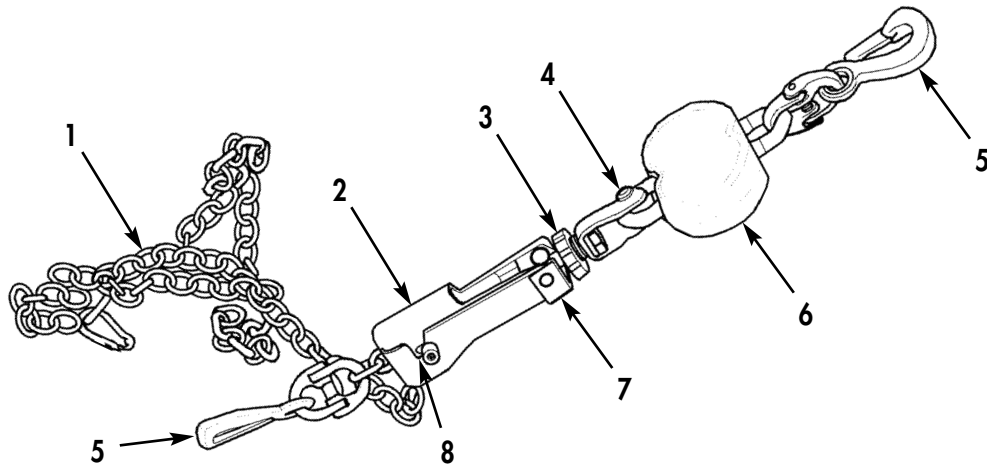

Figure 1. Tiedown Chain Assembly.

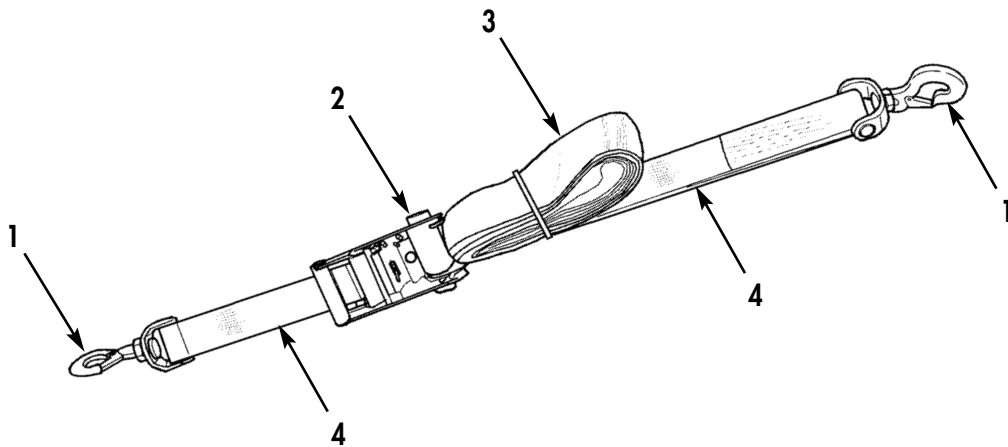

Figure 2. Tiedown Strap Assembly.

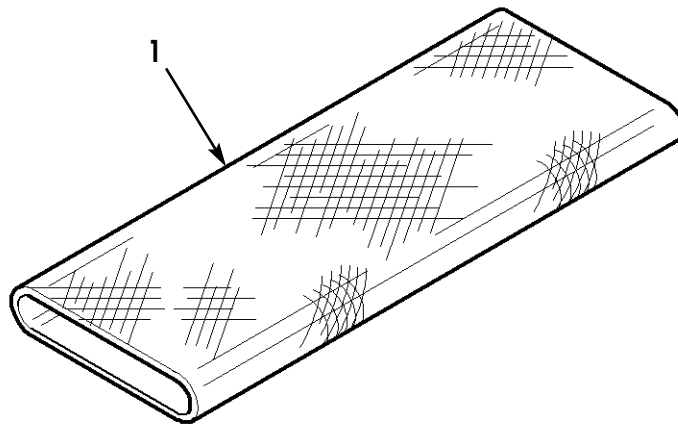

Figure 3. Protective Sleeve.

END OF TASK

END OF WORK PACKAGE

**UNIT MAINTENANCE
FORWARD AREA WATER POINT SUPPLY SYSTEM (FAWPSS)
GENERAL MAINTENANCE**

INITIAL SETUP**Tools**

Tool kit, general mechanic's
(WP 0046, Table 2, Item 1)

References

TM 5-4320-368-14&P
TM 10-5430-245-12&P
TM 10-5430-247-13&P

Materials/Parts

Brush (WP 0049, Item 2)
Cleaning solvent (WP 0049, Item 3)
Soap (WP 0049, Item 5)
Cloth (WP 0049, Item 1)

CLEANING

General maintenance instructions for cleaning, loading for movement, preparation for storage or shipment, and drum and pump unit maintenance are provided in this work package. Publications that provide additional information on general shop practice techniques and preservation are listed in WP 0044.

NOTE

Cleaning procedures will be the same for the majority of parts and components on the FAWPSS. General cleaning procedures are detailed in steps 1 through 4.

1. The Importance of Cleaning – Great care and effort are required in all cleaning operations. The presence of dirt and foreign material is a constant threat to satisfactory equipment operation and maintenance. The following instructions will apply to all cleaning operations.

WARNING

Improper cleaning methods and use of unauthorized cleaning solvents may result in damage to equipment or possible injury to personnel.

CAUTION

Keep all related parts and components together. Do not mix parts. Failure to comply may result in damage to equipment.

- a. Clean all FAWPSS components prior to performing PMCS, lubrication, and maintenance procedures.
- b. Keep hands free of any accumulation of grease which can transfer to FAWPSS components thereby collecting dust and grit.

WARNING

Cleaning solvent compound Skysol 100 mixture is combustible. Use mechanical ventilation whenever product is used in a confined space, is heated above ambient temperatures, or is agitated. DO NOT use or store near heat, sparks, flame, or other ignition sources. Keep container sealed when not in use.

Contact with Skysol 100 cleaning solvent may cause skin irritation. Use chemical resistant gloves. In case of skin contact, remove any contaminated clothing and wash skin thoroughly with soap and water. Wash contaminated clothing before reuse. Eye contact may cause irritation, tearing or blurring of vision, Use face shield or goggles when eye contact may occur. In case of eye contact flush eyes with large amounts of water for at least fifteen (15) minutes or until irritation subsides. Inhalation may cause irritation to upper respiratory passages. DO NOT have food or drink in the vicinity. Failure to comply may result in injury to personnel.

To prevent contamination, do not clean internal surfaces of any FAWPSS hose, valve, or fitting with cleaning solvent compound Skysol 100. Failure to comply may result in injury to personnel.

GENERAL MAINTENANCE (Contd)**CLEANING (Contd)****CAUTION**

Do not allow Skysol 100 to come in contact with seals and flexible hoses. Failure to comply will result in damage to rubber parts.

2. Oil and Grease Covered Surfaces – Use Skysol 100 to remove oil and grease from exterior surfaces of FAWPSS components prior to cleaning dirt, mud, and debris with soap and water.
3. External Surfaces – Clean all accessible external surfaces of FAWPSS components with a soap and water solution and rinse thoroughly. Use a power washer pump where available when cleaning to save time and effort.

WARNING

Do not oil or allow oil to contact inside surfaces of hoses and fittings or contamination and injury to personnel may result.

4. Rusted Surfaces – All parts subject to rusting must be lightly oiled after cleaning and prior to storage. Remove all evidence of corrosion.

END OF TASK**LOADING AND MOVEMENT OF EQUIPMENT****WARNING**

Do not lift a load greater than the rated load capacity of the crane or materiel handling equipment. Failure to comply may result in damage to equipment or possible injury or death to personnel.

All personnel must stand clear of equipment prior to lifting operations or serious injury or death to personnel may result.

NOTE

For specific shipping dimensions and weights, refer to WP 0002, table 6, for FAWPSS Model LAB 9095, and table 9, for FAWPSS Model M105.

1. Shipping Data Plate – Since the FAWPSS is basically a configuration made up of a number of separate end items assembled for a specific purpose, the system itself does not have a shipping data plate. However, the system will be identified on the wooden shipping crates by NSN. Refer to the appropriate TM for shipping information on the collapsible fabric drum and centrifugal pump unit. Refer to References, WP 0044.
2. Loading and Movement – For transportability guidance handling and movement of the FAWPSS, refer to TM 743-200-1, Storage and Materials Handling, and TM 55-2200-001-12, Transportability Guidance for Application of Blocking, Bracing, and Tiedown Materials. Refer to TM 9-2320-279-10 for loading and movement information on the Heavy Expanded Mobility Tactical Truck (HEMTT).
 - a. When unloading the FAWPSS for shipment or storage, ensure cargo bed, pallet, or ground surface is flat, level, and capable of supporting weight of FAWPSS. Refer to Equipment Data, WP 0002, for weights and dimensions.
 - b. Dunnage should be placed under FAWPSS shipping crates during unloading to facilitate tiedown and prevent movement during shipment. Dunnage also prevents damage to bottom of crate when loading/unloading from ground to vehicle.
 - c. The FAWPSS Model M105 can be transported on aircraft when installed on a PLS Flatrack or CROP. Refer to TM 9-3990-206-14&P for PLS Flatrack or TM 9-3990-260-14&P for CROP.

END OF TASK

GENERAL MAINTENANCE (Contd)**PREPARATION FOR SHIPMENT AND LIMITED STORAGE**

1. Cleaning – Protection for FAWPSS components and accompanying equipment must be sufficient to protect the material against deterioration and physical damage.

WARNING

Cleaning solvent compound Skysol 100 mixture is combustible. Use mechanical ventilation whenever product is used in a confined space, is heated above ambient temperatures, or is agitated. DO NOT use or store near heat, sparks, flame, or other ignition sources. Keep container sealed when not in use.

Contact with Skysol 100 may cause skin irritation. Use chemical-resistant gloves. In case of skin contact, remove any contaminated clothing and wash skin thoroughly with soap and water. Wash contaminated clothing before reuse. Eye contact may cause irritation, tearing, or blurring of vision. Use face shield or goggles when eye contact may occur. In case of eye contact, flush eyes with large amounts of water for at least fifteen (15) minutes or until irritation subsides. Inhalation may cause irritation to upper respiratory passages. DO NOT have food or drink in the vicinity. Failure to comply may result in injury to personnel.

To prevent contamination, do not clean internal surfaces of any FAWPSS hose, valve, or fitting with cleaning solvent compound Skysol 100. Failure to comply may result in injury to personnel.

CAUTION

Do not allow Skysol 100 to come in contact with seals and flexible hoses. Failure to comply will result in damage to rubber parts.

NOTE

Prior to application of corrosion preventive compound, surfaces must be cleaned to ensure removal of corrosion, soil, grease, or acid and alkali residues.

- a. Remove all dirt, grease, oil, and other foreign matter from all painted metal surfaces of the FAWPSS by scrubbing with cloths soaked in Skysol 100. Refer WP 0049. Use warm water for cleaning rubber parts.

WARNING

Compressed air source must not exceed 30 psi (207 kPa). When cleaning with compressed air, eyeshields must be worn. Failure to comply may result in injury to personnel.

- b. Clean exterior surfaces FAWPSS equipment and shipping crate by power washing with water, to ensure removal of all dirt and foreign matter. After cleaning, allow parts to air dry, use compressed air, or wipe with clean, dry cloths. Refer to WP 0049.

WARNING

Do not oil or allow corrosion-preventive compound to contact inside surfaces of hoses and fittings or contamination and injury to personnel may result.

2. Preservation – All critical unpainted metal surfaces must be protected during shipment. Coat all unpainted, exposed, or machined metal surfaces on the exterior of the FAWPSS with approved corrosion-preventive compound only. Refer to WP 0049. Equipment protected must be closely watched for signs of corrosion.
3. Packing – Pack all Basic Issue Items (BII) and Additional Authorization List (AAL) items to prevent physical damage. Refer to WP 0047 and WP 0048.
4. Shipment of Army Documents – Prepare all Army shipping documents accompanying FAWPSS in accordance with DA Pam 750-8.

GENERAL MAINTENANCE (Contd)**PREPARATION FOR SHIPMENT AND LIMITED STORAGE (Contd)**

5. Limited Storage Instructions – Commanders are responsible for ensuring that the FAWPSS unit or units issued or assigned to their command are maintained in a serviceable condition and properly cared for, and that personnel under their command comply with technical instructions. Lack of time, trained personnel, or proper tools may result in a unit being incapable of performing maintenance for which it is responsible. In such cases, unit commanders may, with the approval of major commanders, place a FAWPSS that is beyond the maintenance capability of the unit in administrative storage. For detailed information, refer to AR 750-1.
6. Intermediate Storage (46 to 180 days).
 - a. Drain all water from the FAWPSS and all of its components.
 - b. Disassemble the entire FAWPSS by referring to WP 0010 or WP 0011 and performing the disassembly for movement procedures.
 - c. Refer to Preparation for Storage sections of the applicable technical manuals for the pump and engine assembly and collapsible storage drums and prepare those items for long term storage. Refer to References, WP 0044.
 - d. Mark the FAWPSS for intermediate storage in accordance with the standard Army procedure contained in TM 740-90-1, Administration Storage of Equipment.
7. Long Term or Flyable Storage (Indefinite time). Long term storage procedures are the same as for intermediate storage except the FAWPSS shall be marked for long term storage in accordance with TM 740-90-1, Administrative Storage of Equipment.

END OF TASK**ADMINISTRATIVE STORAGE**

1. Placement of equipment in administrative storage should be for short periods of time when a shortage of maintenance effort exists. Items should be in mission readiness within 24 hours or within the time factors determined by the directing authority. During the storage period appropriate maintenance records will be kept.
2. Before placing equipment in administrative storage current maintenance services and equipment Serviceable Criteria (ESC) evaluation should be completed, shortcomings and deficiencies should be corrected, and all Modification work orders (MWO) should be applied.
3. Storage site selection. Inside storage is preferred for items selected for administrative storage. If inside storage is not available, trucks, vans, conex containers and other containers may be used.

END OF TASK**DRUM AND PUMP UNIT MAINTENANCE**

1. For specific instructions governing the maintenance and repair of the collapsible fabric drum, refer to TM 10-5430-245-12&P or TM 10-5430-247-13&P.
2. For specific information governing the maintenance and repair of the centrifugal pump unit, refer to TM 5-4320-368-14&P.

END OF TASK**END OF WORK PACKAGE**

CHAPTER 6

UNIT TROUBLESHOOTING PROCEDURES FOR FORWARD AREA WATER POINT SUPPLY SYSTEM (FAWPSS)

Unit Troubleshooting Symptom Index	WP 0029
Unit Troubleshooting Procedures	WP 0030

**UNIT MAINTENANCE
FORWARD AREA WATER POINT SUPPLY SYSTEM (FAWPSS)
TROUBLESHOOTING SYMPTOM INDEX**

<u>FAULT NO. / SYMPTOM DESCRIPTION TITLE</u>	<u>WORK PACKAGE/PAGE NO.</u>
1. Drums Leaking	0030-2
2. Coupler Valve Leaking or Inoperable.	0030-3
3. Ball Valve Leaking or Inoperable.	0030-4
4. Water Leaking from Hose Assembly	0030-4
5. Nozzle Assembly Leaking	0030-5
6. Components Leaking at Places other than Coupling Connections	0030-5
7. Pump Unit Engine Will Not Start	0030-6
8. Pump Unit Starts But Does Not Pump Water	0030-6
9. Pump Unit Does Not Pump Water at Rated Capacity	0030-6
10. Water has Unusual Odor	0030-7

END OF WORK PACKAGE

**UNIT MAINTENANCE
FORWARD AREA WATER POINT SUPPLY SYSTEM (FAWPSS)
TROUBLESHOOTING PROCEDURES**

INITIAL SETUP**References**

DA Form 2402
DA Form 2404
DA Form 5504
DA Form 5988-E
TM 5-4320-368-14&P
TM 10-5430-245-12&P
TM 10-5430-247-13&P

Equipment Condition

FAWPSS assembled, LAB 9095 (WP 0007) or
M105 (WP 0008)

INTRODUCTION

This work package contains unit level troubleshooting procedures for detecting, isolating, and correcting FAWPSS equipment malfunctions and failures.

Each troubleshooting procedure lists a fault symptom describing a specific problem. Under each symptom is a list of possible malfunctions in the order of probability that may be the cause of the problem. Finally, a corrective action is provided for each malfunction followed by a work package or TM reference or instruction to notify Field maintenance or Sustainment to correct the problem.

Prior to performing any troubleshooting procedure, the following recommendations should be observed.

NOTE

This manual cannot list all possible malfunctions that may occur. If the symptom for a particular problem or malfunction is not listed in this work package, notify your supervisor.

1. Check the Equipment Inspection and Maintenance Worksheet, DA Form 2404 or DA Form 5988-E, and Maintenance Request Form, DA Form 5504 to find out why the equipment has been deadlined. Note the operator's written description of the problem and, whenever possible, ask the operator about the problem. This can save time and effort in diagnosing the malfunction.
2. It is best not to assume the operator's diagnosis is correct, even if it sounds accurate. Always perform the appropriate troubleshooting procedure(s) to verify the cause of the problem. Performing a corrective action without proof of a fault wastes time and increases the maintainability of the equipment.
3. Use the approved unit maintenance tasks provided in this manual and those provided in other publications referenced in this manual.
4. If a problem cannot be corrected after performing all corrective actions listed for a given symptom, notify your supervisor.
5. Fill out and attach an Exchange Tag, DA Form 2402, for any component that will be exchanged as a core and turned in for repair or rebuilding at the Sustainment level.

TROUBLESHOOTING PROCEDURES (Contd)

1. DRUMS LEAKING

SYMPTOM

Water leaking from drum

MALFUNCTION

Adapter assembly leaking

CORRECTIVE ACTION

STEP 1. Depress and release pin at center of adapter assembly to seat check valve and release any possible debris lodged in check valve.

STEP 2. If leaking persists, remove adapter assembly and notify direct support maintenance to repair check valve. Refer to TM 10-5430-245-12&P or TM 10-5430-247-13&P.

MALFUNCTION

Water leaking around bearing plate, swivel plate, or closure ring

CORRECTIVE ACTION

STEP 1. Check for loose mounting hardware. If loose, tight mounting hardware.

STEP 2. If leaking continues, notify direct support maintenance.

MALFUNCTION

Puncture or cut in drum body

CORRECTIVE ACTION

STEP 1. Locate puncture or cut. If hole is 3/8 in. (9.5 mm) DIA or less, plug hole using drum repair kit. Refer to WP 0030.

STEP 2. If hole is larger than 3/8 in. (9.5 mm) DIA, notify direct support maintenance to install vulcanized patch. Refer to TM 10-5430-245-12&P or TM 10-5430-247-13&P.

TROUBLESHOOTING PROCEDURES (Contd)**2. COUPLER VALVE LEAKING OR INOPERABLE****SYMPTOM**

Coupler valve leaking

MALFUNCTION

Water leaking from connection between coupler valve and adapter assembly

CORRECTIVE ACTION

STEP 1. Verify gasket is present between coupler valve and adapter assembly and coupler valve is tight at connection. If coupler valve cannot be tightened and both cam levers are present and locked, check mating surfaces of adapter assembly and coupler valve for damage. Refer to TM 10-5430-245-12&P or TM 10-5430-247-13&P.

STEP 2. If mating surfaces on adapter assembly or coupler valve are damaged, replace damaged adapter assembly or coupler valve. TM 10-5430-245-12&P or TM 10-5430-247-13&P.

MALFUNCTION

Coupler valve leaks at valve stem and packing nut

CORRECTIVE ACTION

STEP 1. Tighten packing nut.

STEP 2. If leaking at stem still occurs after tightening packing nut, notify direct support maintenance.

MALFUNCTION

Coupler valve leaks at outlet when disconnected from system

CORRECTIVE ACTION

Ensure coupler valve handwheel is turned to the left (counterclockwise) all the way. Refer to WP 0004. If valve still leaks, notify direct support maintenance.

MALFUNCTION

Coupler valve handwheel is difficult or impossible to turn.

CORRECTIVE ACTION

STEP 1. Loosen packing nut on valve stem.

STEP 2. If handwheel cannot be turned after loosening packing nut, notify direct support maintenance.

TROUBLESHOOTING PROCEDURES (Contd)

3. BALL VALVE LEAKING OR INOPERABLE

SYMPTOM

Ball valve leaks

MALFUNCTION

Water leaking from connection between ball valve and hose or Y-fitting

CORRECTIVE ACTION

- STEP 1. Ensure both cam arms are locked tight. Refer to WP 0004. If loose, tighten. If both cam arms are tight and ball valve is loose at connection, proceed to next step.
- STEP 2. Disconnect ball valve where leaking and check for missing or damaged gasket. Replace missing or damaged gasket and connect ball valve. If ball valve still cannot be locked tight or still leaks at connection, replace ball valve. Refer to WP 0022.

MALFUNCTION

Ball valve leaks at valve stem

CORRECTIVE ACTION

Replace ball valve. Refer to WP 0022.

MALFUNCTION

Ball valve lever is difficult or impossible to turn

CORRECTIVE ACTION

Replace ball valve. Refer to WP 0022.

4. WATER LEAKING FROM HOSE ASSEMBLY

SYMPTOM

Water leaking at hose connection

MALFUNCTION

Cracked or distorted coupling ends

CORRECTIVE ACTION

If either coupling end of hose assembly is damaged, replace hose assembly.

MALFUNCTION

Missing or worn cam arms on female coupling

CORRECTIVE ACTION

If either coupling cam arm is missing or damaged, replace hose assembly.

TROUBLESHOOTING PROCEDURES (Contd)

5. NOZZLE ASSEMBLY LEAKING

SYMPTOM

Water leaks from nozzle spout, valve, swivel, or coupling at hose connection

MALFUNCTION

Water will not shut off at spout

CORRECTIVE ACTION

STEP 1. Check for sticking lever or valve. If lever is found sticking or binding, straighten lever until free. If lever is damaged, replace nozzle assembly.

STEP 2. If water leaks from sticking valve, replace nozzle assembly. Refer to WP 0023.

MALFUNCTION

Water leaking from valve stem

CORRECTIVE ACTION

STEP 1. Check for loose cap on nozzle valve assembly and tighten if loose.

STEP 2. If cap on nozzle valve is tight and water still leaks from stem, replace nozzle assembly. Refer to WP 0023.

MALFUNCTION

Water leaking from swivel

CORRECTIVE ACTION

If loose, tighten swivel valve. If swivel valve is not loose or still leaks after tightening, replace swivel valve. Refer to WP 0023.

MALFUNCTION

Cracked or distorted coupling

CORRECTIVE ACTION

If coupling is damaged, replace coupling. Refer to WP 0023.

MALFUNCTION

Missing or worn cam arms on coupling

CORRECTIVE ACTION

If coupling cam arms are damaged or missing, replace coupling. Refer to WP 0023.

6. COMPONENTS LEAKING AT PLACES OTHER THAN COUPLING CONNECTIONS

SYMPTOM

Water leaking from fittings at pump suction or discharge ports or pump shaft or casing

MALFUNCTION

Water leaks from pipe fittings on pump

CORRECTIVE ACTION

Tighten or replace loose or damaged pipe fittings. Refer to WP 0028.

TROUBLESHOOTING PROCEDURES (Contd)

6. COMPONENTS LEAKING AT PLACES OTHER THAN COUPLING CONNECTIONS (Contd)

MALFUNCTION

Water leaks from pump shaft or casing

CORRECTIVE ACTION

Maintenance or repair pump. Refer to TM 5-4320-386-14&P.

7. PUMP UNIT ENGINE WILL NOT START

Refer to unit maintenance troubleshooting in appropriate pump unit manual. Refer to TM 5-4320-386-14&P.

8. PUMP UNIT STARTS BUT DOES NOT PUMP WATER

SYMPTOM

No water at nozzles

MALFUNCTION

Pump loses prime

CORRECTIVE ACTION

STEP 1. Prime pump unit to verify pump loses prime.

STEP 2. If pump does not lose its prime and will not pump water, remove couplings and fittings and look for obstruction at suction and discharge ports. If no obstructions are found, repair pump. Refer to TM 5-4320-386-14&P.

STEP 3. If pump loses its prime and no visible leaks can be found in casing such as a loose drain plug, leaking gaskets, or visible cracks, repair pump. Refer to TM 5-4320-386-14&P.

9. PUMP UNIT DOES NOT PUMP WATER AT RATED CAPACITY

SYMPTOM

Water delivered at low volume or low pressure

MALFUNCTION

Engine running at low idle

CORRECTIVE ACTION

STEP 1. Adjust engine to high idle. If engine will not run at high idle, maintenance or repair engine. Refer to TM 5-4320-386-14&P.

STEP 2. If engine runs at high idle and pump does not deliver water at rated capacity, go to next malfunction.

MALFUNCTION

Coupler valve, ball valve, or nozzle assembly improperly set

CORRECTIVE ACTION

STEP 1. Check that handwheel on coupler valve is turned all the way to the right. Refer to WP 0004. Verify coupler valve is fully opening adapter assembly check valve by disconnecting suction hose. If water does not rush out, replace coupler valve.

STEP 2. Check that ball valve lever is in the open position. Refer to WP 0004. Verify ball valve is fully open by disconnecting Y-fitting. If water does not rush out, replace ball valve.

TROUBLESHOOTING PROCEDURES (Contd)

9. PUMP UNIT DOES NOT PUMP WATER AT RATED CAPACITY (Contd)

CORRECTIVE ACTION (Contd)

- STEP 3. Check travel of nozzle valve when lever is fully up. If valve is ok, disconnect nozzle assembly from discharge hose. If water rushes out of discharge hose under considerable pressure, clear obstruction from nozzle assembly or replace nozzle assembly.
- STEP 4. If water does not rush out of discharge hose with considerable pressure, repair pump. Refer to TM 5-4320-386-14&P.

10. WATER HAS UNUSUAL ODOR

SYMPTOM

Water coming from drum has unusual odor at distribution points

WARNING

FAWPSS drums are authorized to be filled with potable drinking water only. If it is suspected that a drum has been used for holding any liquid other than potable water, do not use the water. Failure to comply may result in sickness or death to personnel.

MALFUNCTION

Residual water left in hoses has set form extended period

CORRECTIVE ACTION

- STEP 1. Allow water to run from all nozzles at each distribution point until water is free from odor.
- STEP 2. If odor does not go away after clearing residual water from hoses, notify direct support maintenance.

MALFUNCTION

Drum is contaminated

CORRECTIVE ACTION

- STEP 1. Disconnect contaminated drum from system and drain water from drum. Notify direct support maintenance to disassemble and clean drum, two adapter assemblies, and two coupler valves. Refer to TM 10-5430-245-12&P or TM 10-5430-247-13&P.
- STEP 2. Verify FAWPSS is free from any residual contamination by connecting another drum known to contain clean potable water, and allowing residual water in system to flush out from all nozzles at each distribution point until water is free from odor.

END OF TASK

END OF WORK PACKAGE

CHAPTER 7

PARTS INFORMATION FOR

FORWARD AREA WATER POINT SUPPLY SYSTEM (FAWPSS)

Introduction	WP 0031
GROUP 0100 Hose Assemblies	WP 0032
GROUP 0200 Ball Valve Assembly	WP 0033
GROUP 0300 Nozzle Assembly	WP 0034
GROUP 0400 Nozzle Stand Assembly.....	WP 0035
GROUP 0500 Towing and Lifting Yoke.....	WP 0036
GROUP 0600 Miscellaneous Fittings	WP 0037
GROUP 0700 Fabric Drum Assemblies.....	WP 0038
GROUP 0800 Pump Units	WP 0039
GROUP 0900 Tiedown Assemblies	WP 0040
GROUP 1000 Bulk Materials.....	WP 0041
National Stock Number (NSN) Index.....	WP 0042
Part Number Index	WP 0043

**UNIT MAINTENANCE
FORWARD AREA WATER POINT SUPPLY SYSTEM (FAWPSS)
REPAIR PARTS AND SPECIAL TOOLS LIST (RPSTL) INTRODUCTION**

SCOPE

This RPSTL lists and authorizes spare and repair parts; special tools; special test, measurement, and diagnostic equipment (TMDE); and other special support equipment required for performance of unit maintenance of the FAWPSS. It authorized the requisitioning, issue, and disposition of spare, repair parts, and special tools as indicated by the source, maintenance, and recoverability (SMR) codes.

GENERAL

In addition to this Introduction work package, this RPSTL is divided into the following work packages.

1. **Repair Parts List Work Packages.** Work packages containing lists of spares and repair parts authorized by this RPSTL for use in the performance of maintenance. These work packages also include parts which must be removed for replacement of the authorized parts. Parts lists are composed of functional groups in ascending alphanumeric sequence, with the parts in each group listed in ascending figure and item number sequence. Sending units, brackets, filters, and bolts are listed with the component they mount on. Bulk materials are listed by item name in FIG. BULK at the end of the work packages. Repair parts kits are listed separately in their own functional group and work package. Items listed are shown on the associated illustrations.
2. **Special Tools List Work Packages.** Work packages containing lists of special tools, special TMDE and special support equipment authorized by this RPSTL (as indicated by Basis Of Issue (BOI) information in the DESCRIPTION AND USABLE ON CODE (UOC) column). Tools that are components of common tool sets and/or Class VII are not listed.
3. **Cross-Reference Indexes Work Packages.** There are two cross-reference index work packages in this RPSTL: the National Stock Number (NSN) Index work package, and the Part Number (P/N) Index work package (WP 0042 and WP 0043). The National Stock Number Index work package refers you to the figure and item number. The Part Number Index work package refers you to the figure and item number.

EXPLANATION OF COLUMNS IN THE RPSTL WORK PACKAGES

Item No. (Column 1). Indicates the number used to identify items called out in the illustration.

SMR Code (Column 2). The Source, Maintenance, and Recoverability (SMR) code is a 5-position code containing supply/requisitioning information, maintenance category authorization criteria, and disposition instruction, as shown in the following breakout:

*Complete Repair: Maintenance capacity, capability, and authority to perform all corrective maintenance

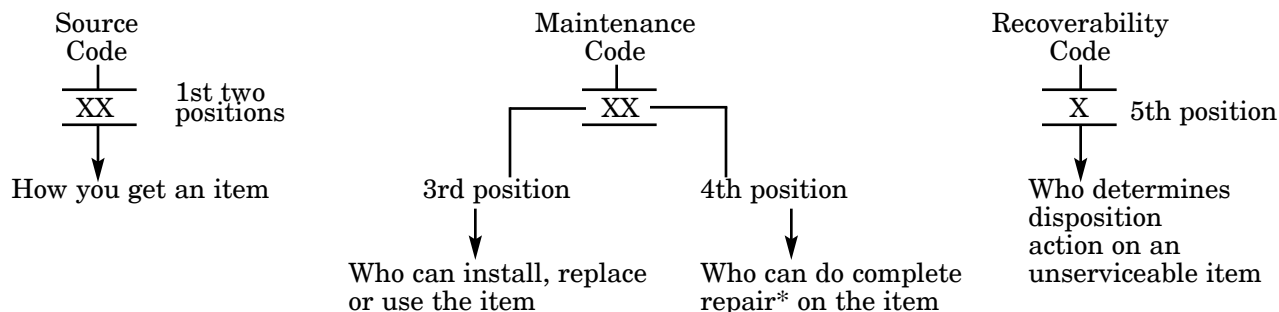

tasks of the “repair” function in a use/user environment in order to restore serviceability to a failed item.

Source Code (1st two positions). The source code tells you how to get an item needed for maintenance, repair, or overhaul of an end item/equipment. Explanations of source codes follows.

Code	Explanation
PA	Stocked items; use the applicable NSN to request/requisition items with these source codes. They are authorized to the category indicated by the code entered in the third position of the SMR code. ** NOTE: Items coded PC are subject to deterioration.
PB	
PC**	
PD	
PE	
PF	
PG	
KD	Items with these codes are not to be requested/requisitioned individually. They are part of a kit which is authorized to the maintenance category indicated in the third position of the SMR code. The complete kit must be requisitioned and applied.
KF	
KB	
MO- (Made at Unit/AVUM Level)	Items with these codes are not to be requested/requisitioned individually. They must be made from bulk material which is identified by the part number in the DESCRIPTION AND USABLE ON CODE (UOC) column and listed in the bulk material group of the repair parts list. If the item is authorized to you by the third position code of the SMR code, but the source code indicates it is made at a higher level, order the item from the higher level of maintenance.
MF- (Made at DS/AVUM Level)	
MH- (Made at GS Level)	
ML- (Made at Specialized Repair Activity (SRA) (Made at Depot)	
AO- (Assembled by Unit/AUVM Level)	Items with these codes are not to be requested/requisitioned individually. The parts that make up the assembled item must be requisitioned or fabricated and assembled at the level of maintenance indicated by the source code. If the third position code of the SMR code authorized you to replace the item, but the source code indicates the item is assembled at a higher level, order the item from the higher level of maintenance.
AF- (Assembled by DS/AVIM Level)	
AH- (Assembled by GS Category)	
AL- (Assembled by SRA) (Assembled by SRA) (Assembled by Depot)	
AD- (Assembled by SRA) (Assembled by Depot)	
XA-	Do not requisition an XA-coded item. Order the next higher assembly. (Refer to the note below.)
XB-	If an XB item is not available from salvage, order it using the CAGEC and Part Number (P/N) given.
XC-	Installation drawing, diagram, instruction sheet, field service drawing, that is identified by manufacturer's part number.
XD-	Item is not stocked. Order an XD-coded item through normal supply channels using the CAGEC and part number given, if no National Stock Number (NSN) is available.

NOTE

Cannibalization or controlled exchange, when authorized, may be used as a source of supply for items with the above source codes, except for source code XA.

Maintenance Code (3rd and 4th positions). Maintenance codes tell you the level(s) of maintenance authorized to USE and REPAIR support items. The maintenance codes are entered in the third and fourth positions of the SMR code as follows:

- a. The maintenance code entered in the third position tells you the lowest maintenance level authorized to remove, replace, and use an item. The maintenance code entered in the third position will indicate authorization to one of the following levels of maintenance.

Code	Application/Explanation
C	- Crew or operator maintenance done within organizational maintenance.
O	- Unit level can remove, replace, and use the item.
F	- Direct support level can remove, replace, and use the item.
H	- General support level can remove, replace, and use the item.
L	- Specialized repair activity can remove, replace, and use the item.
D	- Depot level can remove, replace, and use the item.

- b. The maintenance code entered in the fourth position tells you whether or not the item is to be repaired and identifies the lowest maintenance level with the capability to do complete repair (i.e., perform all authorized repair functions).

NOTE

Some limited repair may be done on the item at a lower level of maintenance, if authorized by the Maintenance Allocation Chart

Code	Application/Explanation
O	– Unit/AVUM is the lowest level that can do complete repair of the item.
F	– Direct support is the lowest level that can do complete repair of the item.
H	– General support is the lowest level that can do complete repair of the item.
L	– Specialized repair activity is the lowest level that can do complete repair of the item.
D	– Depot is the lowest level that can do complete repair of the item.
Z	– Nonrepairable. No repair is authorized.
B	– No repair is authorized. (No parts or special tools are authorized for the maintenance of a B-coded item.) However, the item may be reconditioned by adjusting, lubricating, etc., at the user level.

Recoverability Code (5th position). Recoverability codes are assigned to items to indicate the disposition action on unserviceable items. The recoverability code is entered in the fifth position of the SMR code as follows:

Recoverability Code	Application/Explanation
Z	– Nonrepairable item. When unserviceable, condemn and dispose of the item at the level of maintenance shown in 3rd position of SMR code.
O	– Repairable item. When uneconomically repairable, condemn and dispose of the item at unit or AVUM level.
F	– Repairable item. When uneconomically repairable, condemn and dispose of the item at the direct support AVIM level.
H	– Repairable item. When uneconomically repairable, condemn and dispose of the item at the general support level.
D	– Repairable item. When beyond lower level repair capability, return to depot. Condemnation and disposal of item not authorized below depot level.
L	– Repairable item. Condemnation and disposal not authorized below specialized repair activity (SRA).
A	– Item requires special handling or condemnation procedures because of specific reasons (e.g., precious metal content, high dollar value, critical material, or hazardous material). Refer to appropriate manuals/directives for specific instructions.

CAGEC (Column (3)). The Commercial and Government Entity Code (CAGEC) is a 5-digit numeric code which is used to identify the manufacturer, distributor, or Government agency/activity, that supplies the item.

Part Number (Column (4)). Indicates the primary number used by the manufacturer (individual, company, firm, corporation, or Government activity), which controls the design and characteristics of the item by means of its engineering drawings, specifications, standards, and inspection requirements to identify an item or range of items.

NOTE

When you use an NSN to requisition an item, the item you receive may have a different part number from the part ordered.

Description and Usable On Code (UOC) (Column 6). This column includes the following information:

- (1) The Federal item name and, when required, a minimum description to identify the item.
- (2) Part numbers of bulk materials are referenced in this column in the line entry to be manufactured/fabricated.
- (3) The statement "END OF FIGURE" appears just below the last item description in Column (5) for a given fixture in both Section II and Section III.

QTY (Column 7). The QTY (quantity per figure column) indicates the quantity of the item used in the breakout shown on the illustration figure, which is prepared for a functional group, subfunctional group, or an assembly. A V appearing in this column in lieu of a quantity indicates that the quantity is variable and the quantity may change from application to application.

EXPLANATION OF CROSS-REFERENCE INDEXES WORK PACKAGES FORMAT AND COLUMNS**1. National Stock Number (NSN) Index Work Packages.**

STOCK NUMBER Column. This column lists the NSN by National Item Identification Number (NIIN) sequence. The NIIN consists of the last nine digits of the NSN (i.e.

$$\begin{array}{c} \text{NSN} \\ \hline 5305-01-574-1467 \\ \hline \text{NIIN} \end{array}$$

When using this column to locate an item, ignore the first 4 digits of the NSN. Use the complete NSN (13 digits) when requisitioning items by stock number.

FIG. Column. This column lists the number of the figure where the item is identified/located. The figures are in numerical order in the repair parts and special tools list work packages.

ITEM Column. The item number identifies the item associated with the figure listed in the adjacent FIG. column. This item is also identified by the NSN listed on the same line.

2. Part Number Index. Part numbers in this index are listed by part number in ascending numericalalpha sequence (i.e., vertical arrangement of letter and number combination which places the first letter or digit of each group in order A through Z, followed by the numbers 0 through 9 and each following letter or digit in like order).

CAGEC Column. The Commercial and Government Entity Code (CAGEC) is a 5-digit numeric code used to identify the manufacturer, distributor, or Government agency, etc., that supplies the item.

PART NUMBER Column. Indicates the primary number used by the manufacturer (individual, company, firm, corporation, or Government activity), which controls the design and characteristics of the item by means of its engineering drawings, specifications standards, and inspection requirements to identify an item or range of items.

STOCK NUMBER Column. This column lists the NSN for the associated part number and manufacturer identified in the PART NUMBER and CAGEC columns to the left

FIG. Column. This column lists the number of the figure where the item is identified/located in Section II and Section III.

ITEM Column. The item number is that number assigned to the item as it appears in the figure referenced in the adjacent figure number column.

3. Figure and Item Number Index.

FIG. Column. This column lists the number of the figure where the item is identified/located in Section II and Section III.

ITEM Column. The item number is that number assigned to the item as it appears in the figure referenced in the adjacent figure number column.

STOCK NUMBER Column. This column lists the NSN for item.

CAGEC Column. The Commercial and Government Entity Code (CAGEC) is a 5-digit numeric code used to identify the manufacturer, distributor, or Government agency, etc., that supplies the item.

Part Number. Indicates the primary number used by the manufacturer (individual, company, firm, corporation, or Government activity), which controls the design and characteristics of the item by means of its engineering drawings, specifications standards, and inspection requirements to identify an item or range of items.

SPECIAL INFORMATION

USABLE ON CODE. The usable on code appears in the lower left corner of the Description column heading. Usable on codes are shown as "UOC: . . ." in the Description Column (justified left) on the last line of the applicable item description/nomenclature. Uncoded items are applicable to all models.

Identification of the usable on codes used in the RPSTL are:

Code	Used On
FFV	LAB 9095
FNQ	JGB-FAWPSS-432034612P
MMH	M105

Fabrication Instructions. Bulk materials required to manufacture items are listed in the Bulk Material Functional Group of this RPSTL. Part numbers for bulk materials are also referenced in the description column of the line item entry for the item to be manufactured/fabricated. Detailed fabrication instructions for items source code to be manufactured or fabricated are found in Appendix G of this technical manual.

Index Numbers. Items which have the word BULK in the figure column will have an index number shown in the item number column. This index number is a cross-reference between the National Stock Number/Part Number Index and the bulk material list in Section II.

Associated Publications. Refer to References, WP 0044.

HOW TO LOCATE REPAIR PARTS

When National Stock Number or Part Number is Not Known.

(1) **First.** Using the table of contents, determine the assembly group or subassembly group to which the item belongs. This is necessary since figures are prepared for assembly groups and subassembly groups, and listings are divided into the same groups.

(2) **Second.** Find the figure covering the assembly group or subassembly group to which the item belongs.

(3) **Third.** Identify the item on the figure and use the Figure and Item Number Index to find the NSN.

When National Stock Number or Part Number Is Known.

(1) **First.** using the National Stock Number and Part Number Indexes, find the pertinent National stock Number or Part Number. The NSN index is in National Item Identification Number (NIIN) sequence (see paragraph 4.a.). The part numbers in the Part Number index are listed in ascending alphanumeric sequence (see paragraph 4.b.). Both indexes cross-reference you to the illustration./figure and item number of the item you are looking for.

(2) **Second.** After finding the figure and item number, verify that the item is the one you're looking for, then the item number in the repair parts list for the figure.

ABBREVIATIONS

Abbreviations used in this manual are listed in MIL-STD-12. No uncommon abbreviations are used.

END OF WORK PACKAGE

FORWARD AREA WATER POINT SUPPLY SYSTEM (FAWPSS)
 LAB 9095 (NSN 4320-01-359-0369)
 M105 (NSN 4320-01-532-7057)

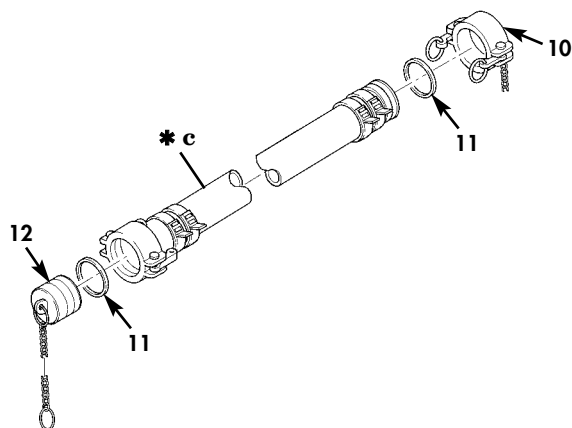
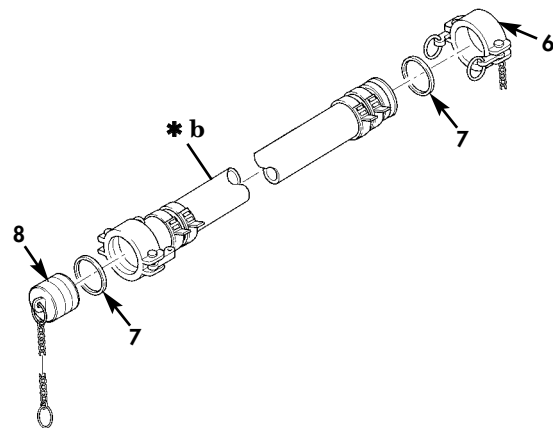
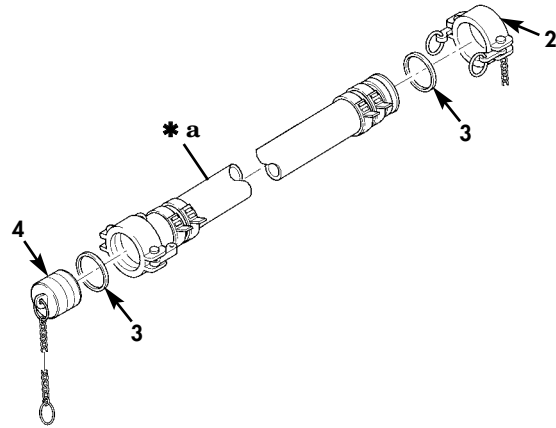
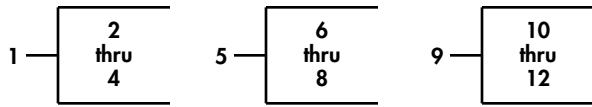

- * a PART OF ITEM 1
- * b PART OF ITEM 5
- * c PART OF ITEM 9

Figure 1. Hose Assemblies.

(1) ITEM NO	(2) SMR CODE	(3) NSN	(4) CAGEC	(5) PART NUMBER	(6) DESCRIPTION AND USABLE ON CODE (UOC)	(7) QTY
GROUP 0100 HOSE ASSEMBLIES						
FIG. 1 HOSE ASSEMBLIES						
1	PAOZZ	4720-01-163-4683	97403	13225E9135-1	HOSE ASSEMBLY,NONME SUCTION,2 INCH DIAMETER,10 FOOT LENGTH..... UOC:FFV,FNQ	4
1	PAOZZ	4720-01-163-4683	97403	13225E9135-1	HOSE ASSEMBLY,NONME SUCTION,2 INCH DIAMETER,10 FOOT LENGTH..... UOC:MMH	12
2	PAOZZ	4730-00-649-9100	58536	AA59326IX16	.CAP,QUICK DISCONNED.....	1
3	PAOZZ	5330-00-612-2414	58536	AA59326-G6	.GASKET.....	2
4	PAOZZ	4730-00-915-5127	58536	AA59326X16	.PLUG,QUICK DISCONNED.....	1
5	PAOZZ	4720-01-175-5957	97403	13225E9136-5	HOSE ASSEMBLY,NONME DISCHARGE ONLY,2 INCH DIAMETER,25 FOOT LENGTH UOC:FFV,FNQ	2
5	PAOZZ	4720-01-175-5957	97403	13225E9136-5	HOSE ASSEMBLY,NONME DISCHARGE ONLY,2 INCH DIAMETER,25 FOOT LENGTH UOC:MMH	4
6	PAOZZ	4730-00-649-9100	58536	AA59326IX16	.CAP,QUICK DISCONNED.....	1
7	PAOZZ	5330-00-612-2414	58536	AA59326-G6	.GASKET.....	2
8	PAOZZ	4730-00-915-5127	58536	AA59326X16	.PLUG,QUICK DISCONNED.....	1
9	PAOZZ	4720-01-174-8173	97403	13225E9136-11	HOSE ASSEMBLY,NONME DISCHARGE ONLY,1.5 INCH DIAMETER,25 FOOT LENGTH..... UOC:FFV,FNQ	4
9	PAOZZ	4720-01-174-8173	97403	13225E9136-11	HOSE ASSEMBLY,NONME DISCHARGE ONLY,1.5 INCH DIAMETER,25 FOOT LENGTH..... UOC:MMH	8
10	PAOZZ	4730-00-869-5246	58536	AA59326/10-5	.CAP,QUICK DISCONNED.....	1
11	PAOZZ	5330-00-360-0595	14555	110-5	.GASKET.....	2
12	PAOZZ	4730-00-823-5316	58536	AA59326X15	.PLUG,QUICK DISCONNED.....	1

END OF FIGURE

FORWARD AREA WATER POINT SUPPLY SYSTEM (FAWPSS)
LAB 9095 (NSN 4320-01-359-0369)
M105 (NSN 4320-01-532-7057)

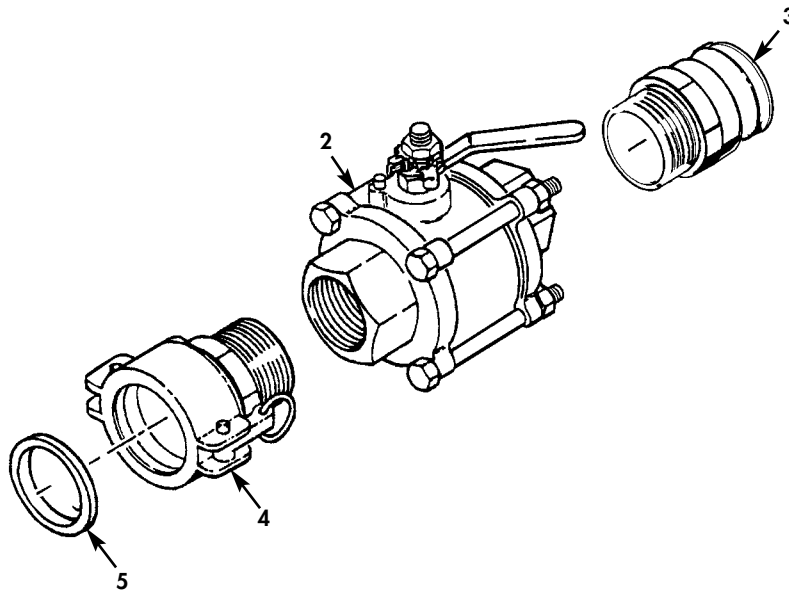
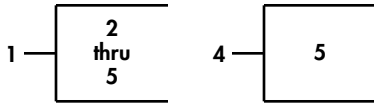

Figure 2. Ball Valve Assembly.

(1) ITEM NO	(2) SMR CODE	(3) NSN	(4) CAGEC	(5) PART NUMBER	(6) DESCRIPTION AND USABLE ON CODE (UOC)	(7) QTY
GROUP 0200 BALL VALVE ASSEMBLY						
FIG. 2 BALL VALVE ASSEMBLY						
1	A0000		1U339	13225E9137	VALVE,BALL..... UOC:FFV,FNQ	2
1	A0000		1U339	13225E9137	VALVE,BALL..... UOC:MMH	6
2	PAOZZ	4820-00-330-5466	82666	S-127-BR-R-T-2IN	.VALVE,BALL.....	1
3	PAOZZ	4730-00-938-7997	58536	AA59326III16	.COUPLING HALF,QUICK.....	1
4	PAOZZ	4730-00-088-9285	58536	AA59326VII16	.COUPLING HALF,QUICK.....	1
5	PAOZZ	5330-00-612-2414	58536	AA59326-G6	..GASKET.....	1

END OF FIGURE

FORWARD AREA WATER POINT SUPPLY SYSTEM (FAWPSS)
 LAB 9095 (NSN 4320-01-359-0369)
 M105 (NSN 4320-01-532-7057)

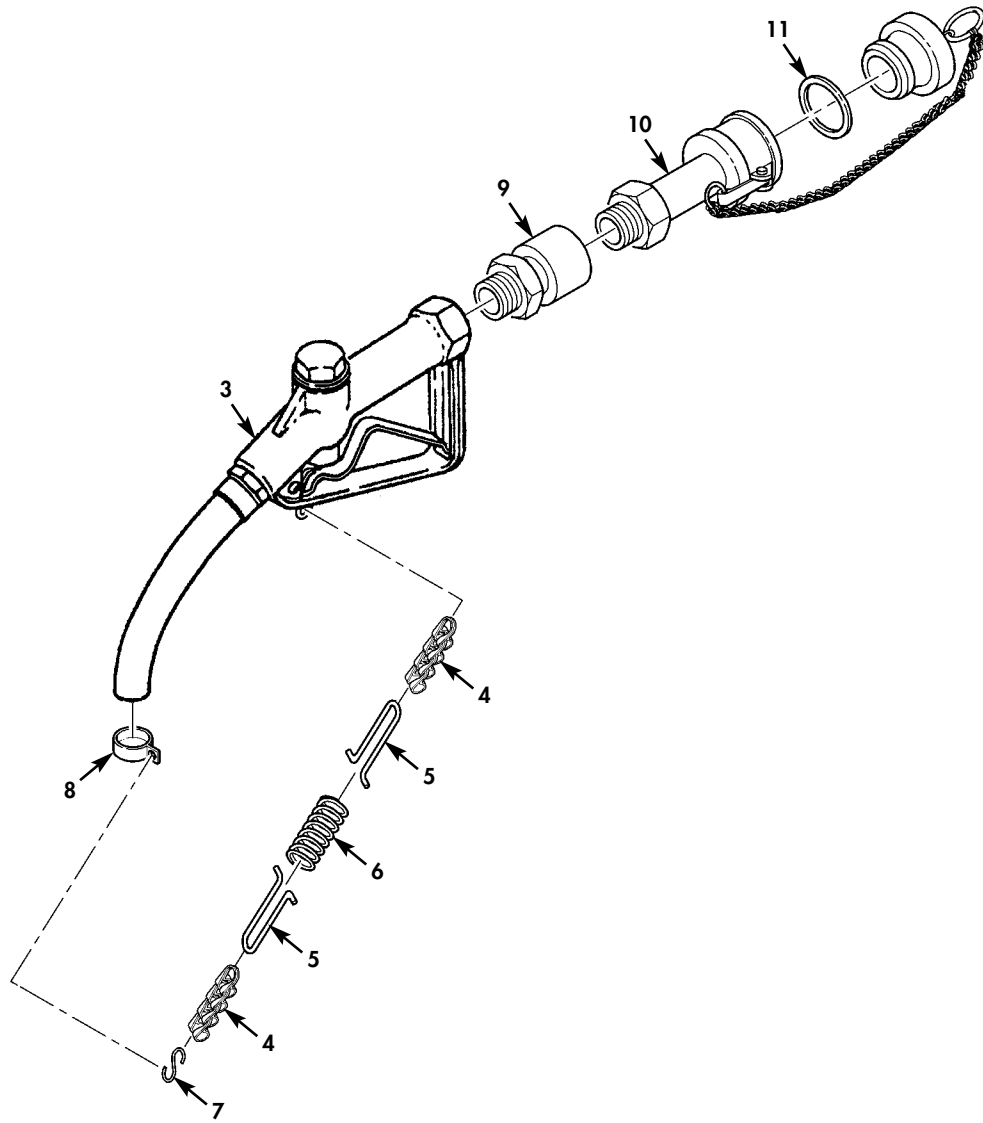
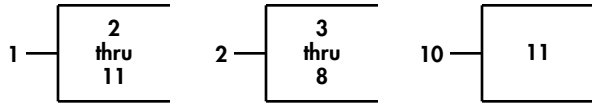

Figure 3. Nozzle Assembly.

(1) ITEM NO	(2) SMR CODE	(3) NSN	(4) CAGEC	(5) PART NUMBER	(6) DESCRIPTION AND USABLE ON CODE (UOC)	(7) QTY
GROUP 0300 NOZZLE ASSEMBLY						
FIG. 3 NOZZLE ASSEMBLY						
1	A0000		97403	13225E9095-12/13 /22	NOZZLE,ASSEMBLY..... UOC:FFV,FNQ	4
1	A0000		97403	13225E9095-12/13 /22	NOZZLE,ASSEMBLY..... UOC:MMH	8
2	PAOOO	4610-01-188-8197	81718	811-PW	.NOZZLE,WATER DISTRI.....	1
3	XAOZZ		41952	300ALM-BODY	..NOZZLE.....	1
4	XBOZZ		81718	H-9112-M	..CHAIN.....	1
5	XBOZZ		81718	H-9210-M	..DRAW BAR.....	2
6	XBOZZ		81718	H-9209-M	..COMPRESSION SPRING.....	1
7	XBOZZ		81718	H-3283-M	..CAP LINK.....	2
8	XBOZZ		81718	H-9116-AS	..DUST CAP.....	1
9	PAOZZ	4730-01-189-1233	41592	122HWA0100 1S	.SWIVEL JOINT,PIPE.....	1
10	PAOZZ	4730-01-126-3825	58536	AA59326A/14-8-A- 1	.COUPLING HALF,QUICK.....	1
11	PAOZZ	5330-00-360-0595	14555	110-5	..GASKET.....	1

END OF FIGURE

FORWARD AREA WATER POINT SUPPLY SYSTEM (FAWPSS)
LAB 9095 (NSN 4320-01-359-0369)
M105 (NSN 4320-01-532-7057)

1 — 2
thru
7

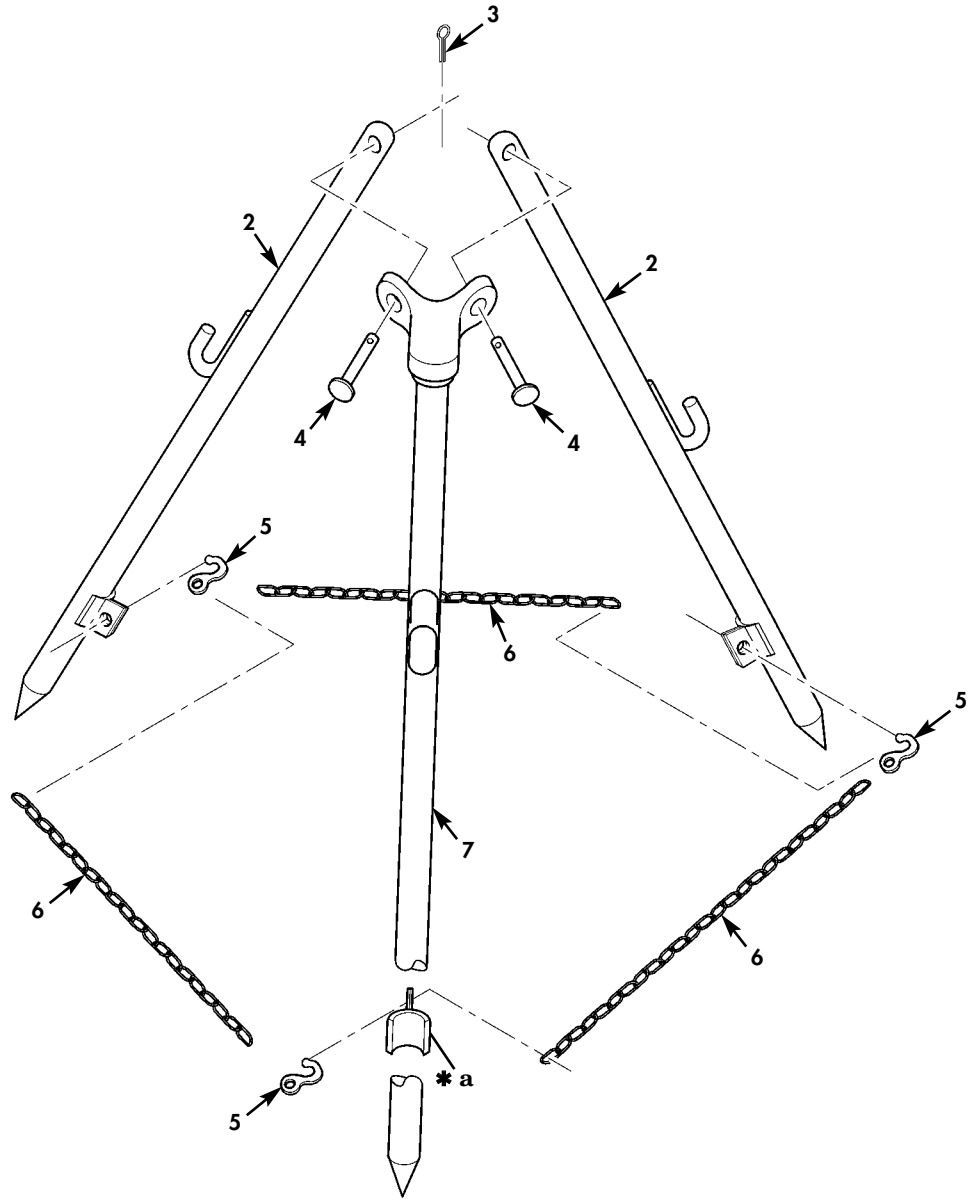

* a PART OF ITEM 7

Figure 4. Nozzle Stand Assembly.

(1) ITEM NO	(2) SMR CODE	(3) NSN	(4) CAGEC	(5) PART NUMBER	(6) DESCRIPTION AND USABLE ON CODE (UOC)	(7) QTY
GROUP 0400 NOZZLE STAND ASSEMBLY						
FIG. 4 NOZZLE STAND ASSEMBLY						
1	PAOOO	4930-01-120-7426	97403	13225E9140	STAND ASSEMBLY,DIST.....	2
2	PFOZZ	6530-01-472-7847	66732	13225E9146	.LEG,CLEVIS.....	2
3	PAOZZ	5315-00-839-5820	80205	MS24665-134	.PIN,COTTER 1/16 NOM DIA X 3/4 LG.	2
4	PAOZZ	5315-00-812-1236	96906	MS20392-3C35	.PIN,STRAIGHT,HEADED 1/4 NOM DIA X 1.094 EFF LG STEEL.....	2
5	PAOZZ	4030-00-948-7315	96906	MS87006-33	.HOOK,CHAIN,S 0.120 DIA X 1-7/16 REACH.....	3
6	MOOOO		81349	RR-C-271-45	.CHAIN MAKE FROM CHAIN,WELDLESS P/N RR-C-271,45 LINKS.....	3
7	PFOZZ	6530-01-472-7843	66732	13225E9145	.PIVOT,LEG,TRIPOD.....	1

END OF FIGURE

FORWARD AREA WATER POINT SUPPLY SYSTEM (FAWPSS)
LAB 9095 (NSN 4320-01-359-0369)
M105 (NSN 4320-01-532-7057)

1 — 2 thru 13

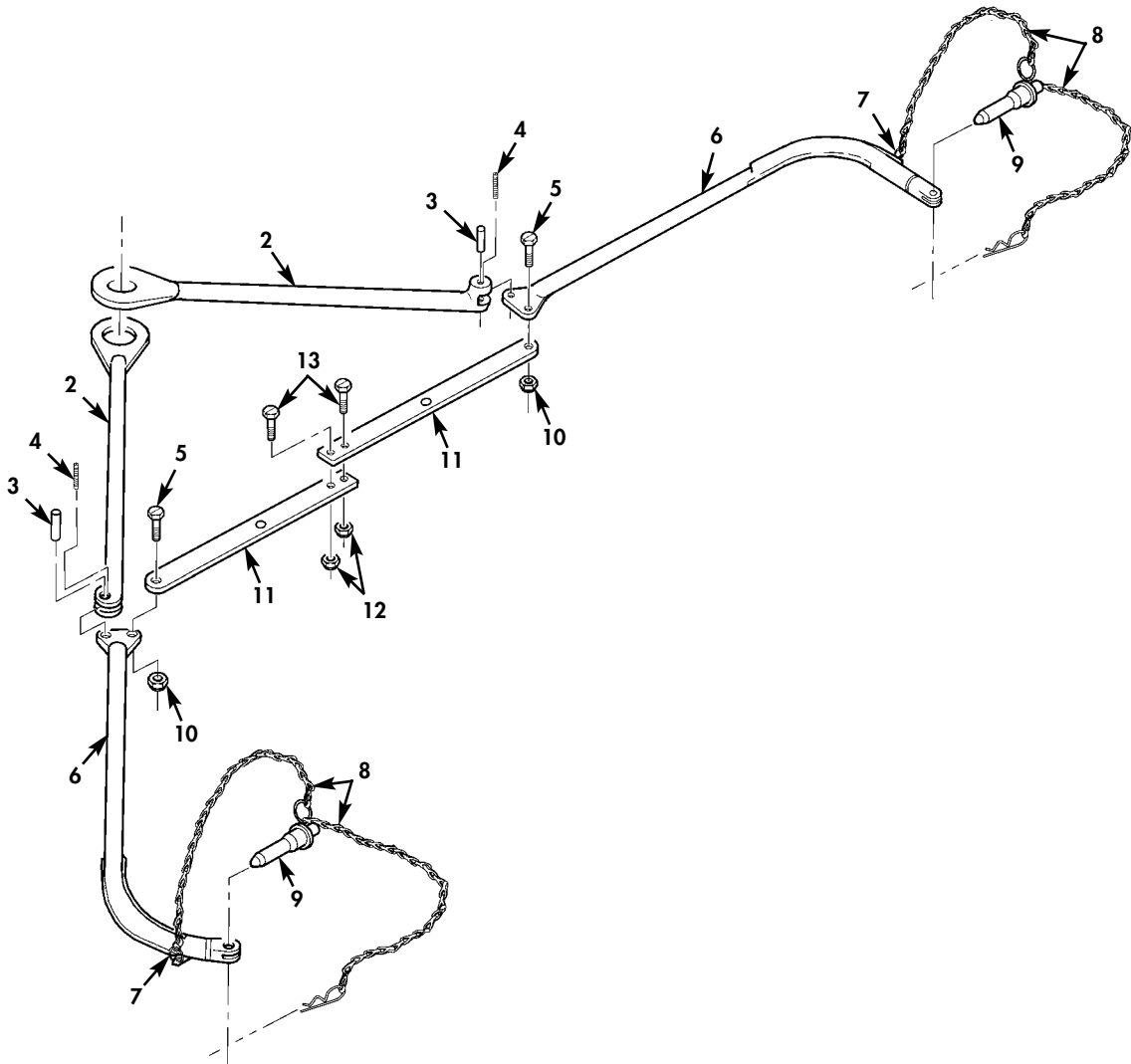

Figure 5. Towing and Lifting Yoke.

(1) ITEM NO	(2) SMR CODE	(3) NSN	(4) CAGEC	(5) PART NUMBER	(6) DESCRIPTION AND USABLE ON CODE (UOC)	(7) QTY
GROUP 0500 TOWING AND LIFTING YOKE						
FIG. 5 TOWING AND LIFTING YOKE						
1	PAOOZ	8110-00-856-6243	81349	MIL-Y-40628	YOKE,TOWING AND LIF..... UOC:FFV,FNQ	1
2	XBOZZ		97403	13216E7993	.LEG,UPPER..... UOC:FFV,FNQ	2
3	PAOZZ	5315-01-105-7350	97403	13216E7995	.PIN,STRAIGHT,HEADLE..... UOC:FFV,FNQ	2
4	PAOZZ	5305-00-723-9387	96906	MS51963-63	.SETSCREW 0.250-20 X 0.250 LG..... UOC:FFV,FNQ	2
5	PAOZZ	5305-00-941-3579	80205	MS35307-463	.SCREW,CAP,HEXAGON H 5/8-11 X 1.750 LG..... UOC:FFV,FNQ	2
6	XBOZZ		97403	13216E7992	.LEG,CONNECTING..... UOC:FFV,FNQ	2
7	PAOZZ	4030-00-948-7315	96906	MS87006-33	.HOOK,CHAIN,S 0.120 DIA X 1-7/16 REACH..... UOC:FFV,FNQ	2
8	MOOOO		81349	RR-C-271-AR	.CHAIN MAKE FROM CHAIN,WELDLESS P/N RR-C-271,LENGTH AS REQUIRED.... UOC:FFV,FNQ	4
9	PAOZZ	5315-01-258-6496	99984	33290	.CLEVIS PIN ASSEMBLY..... UOC:FFV,FNQ	2
10	PAOZZ	5310-00-245-8826	96906	MS16228-10C	.NUT,SELF-LOCKING,HE 5/8-11 UNC-3B UOC:FFV,FNQ	2
11	XBOZZ		97403	13216E7994	.BRACE..... UOC:FFV,FNQ	2
12	PAOZZ	5310-00-241-6667	96906	MS16228-8C	.NUT,SELF-LOCKING,HE 1/2-13 UNC-3B UOC:FFV,FNQ	2
13	PAOZZ	5305-00-727-6804	80205	MS35307-414	.SCREW,CAP,HEXAGON H 1/2-13 X 1.750 LG..... UOC:FFV,FNQ	2

END OF FIGURE

FORWARD AREA WATER POINT SUPPLY SYSTEM (FAWPSS)
LAB 9095 (NSN 4320-01-359-0369)
M105 (NSN 4320-01-532-7057)

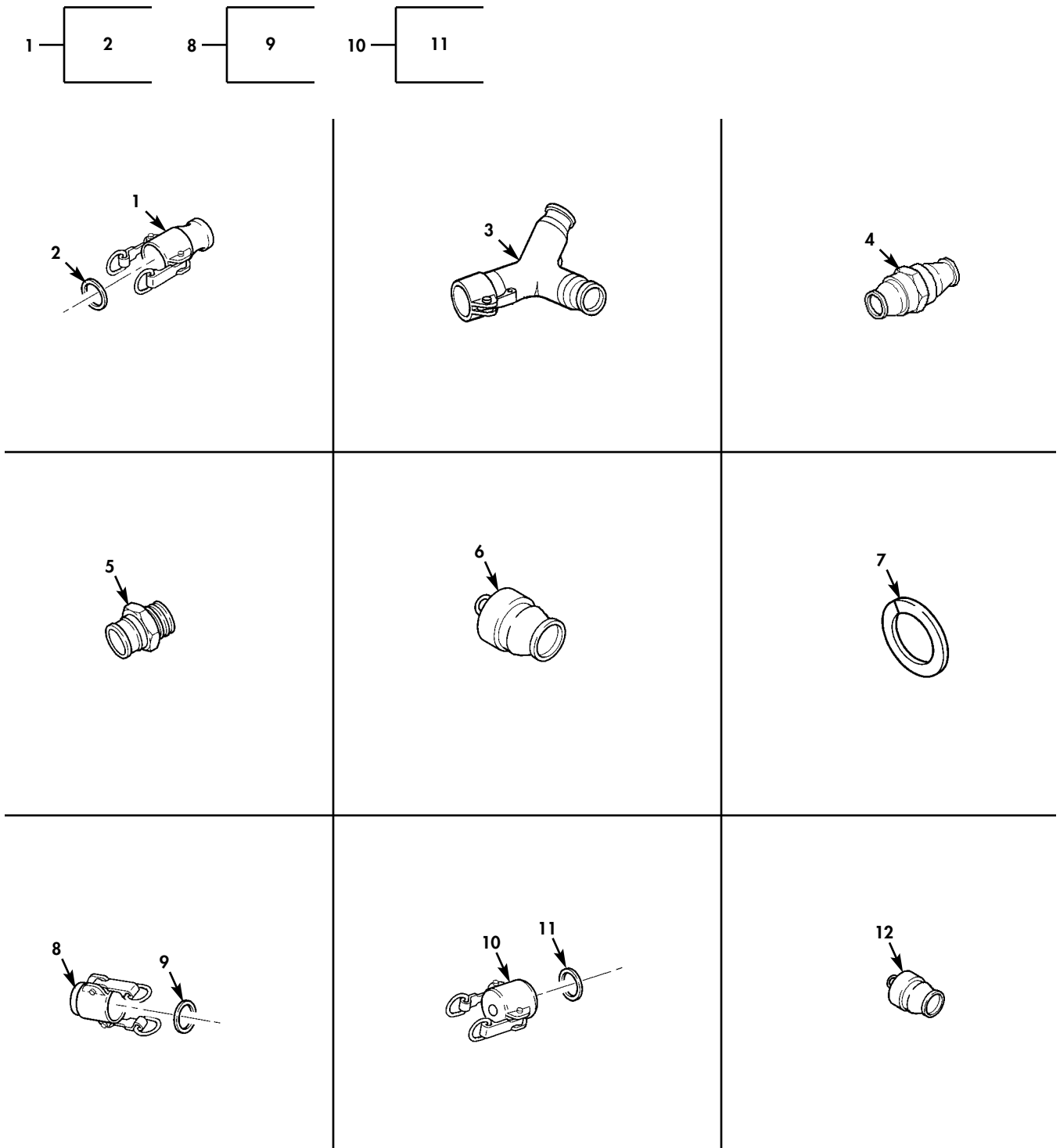
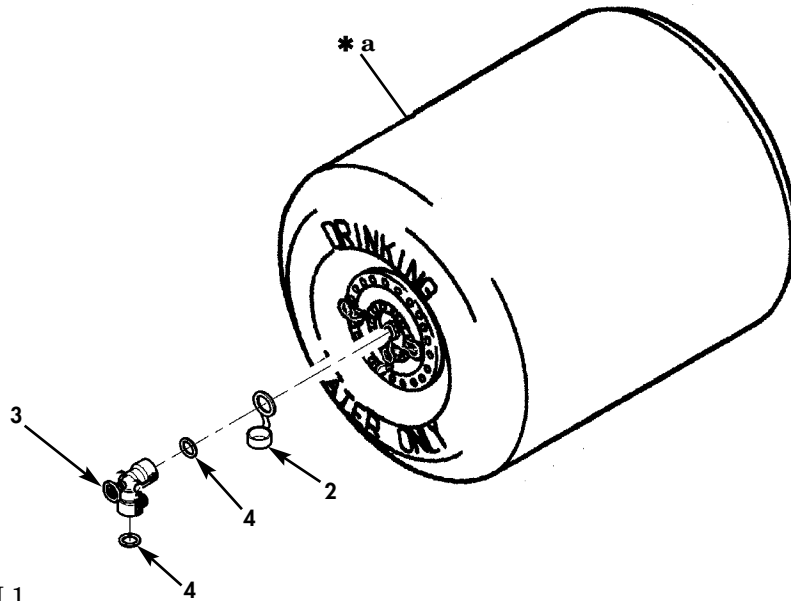
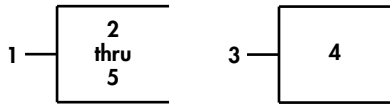

Figure 6. Miscellaneous Fittings.

(1) ITEM NO	(2) SMR CODE	(3) NSN	(4) CAGEC	(5) PART NUMBER	(6) DESCRIPTION AND USABLE ON CODE (UOC)	(7) QTY
GROUP 0600 MISCELLANEOUS FITTINGS						
FIG. 6 MISCELLANEOUS FITTINGS						
1	PAOZZ	4730-00-951-3295	81718	633BA-2X1-1/2AL	REDUCER,QUICK DISCO..... UOC:FFV,FNQ	4
1	PAOZZ	4730-00-951-3295	81718	633BA-2X1-1/2AL	REDUCER,QUICK DISCO..... UOC:MMH	8
2	PAOZZ	5330-00-612-2414	58536	AA59326-G6	.GASKET.....	1
3	PAOZZ	4730-01-317-0694	0U9Z1	319-K	WYE,QUICK DISCONNEC..... UOC:FFV,FNQ	4
3	PAOZZ	4730-01-068-5070	81718	319K-2	WYE,QUICK DISCONNEC..... UOC:MMH	10
4	PAOZZ	4730-01-009-1735	58536	AA59326XXI15	NIPPLE,QUICK-DISCON..... UOC:FFV,FNQ	1
4	PAOZZ	4730-01-009-1735	58536	AA59326XXI15	NIPPLE,QUICK-DISCON..... UOC:MMH	2
5	PAOZZ	4730-00-938-7997	58536	AA59326III16	COUPLING HALF,QUICK..... UOC:FFV,FNQ	1
5	PAOZZ	4730-00-938-7997	58536	AA59326III16	COUPLING HALF,QUICK..... UOC:MMH	6
6	PAOZZ	4730-00-915-5127	58536	AA59326X16	PLUG,QUICK DISCONNE..... UOC:FFV,FNQ	2
6	PAOZZ	4730-00-915-5127	58536	AA59326X16	PLUG,QUICK DISCONNE..... UOC:MMH	14
7	PAOZZ	5325-00-926-5411	81718	H01434M	RING,RETAINING (KEY RING)..... UOC:FFV,FNQ	7
7	PAOZZ	5325-00-926-5411	81718	H01434M	RING,RETAINING (KEY RING)..... UOC:MMH	30
8	PAOZZ	4730-00-649-9103	58536	AA59326V16	COUPLING HALF,QUICK..... UOC:FFV,FNQ	1
9	PAOZZ	5330-00-612-2414	58536	AA59326-G6	.GASKET..... UOC:FFV,FNQ	1
10	PAOZZ	4730-00-649-9100	58536	AA59326IX16	CAP,QUICK DISCONNEC..... UOC:FFV,FNQ	3
10	PAOZZ	4730-00-649-9100	58536	AA59326IX16	CAP,QUICK DISCONNEC..... UOC:MMH	8
11	PAOZZ	5330-00-612-2414	58536	AA59326-G6	.GASKET..... UOC:FFV,FNQ	1
12	PAOZZ	4730-00-823-5316	58536	AA59326X15	PLUG,QUICK DISCONNE.....	8

END OF FIGURE

FORWARD AREA WATER POINT SUPPLY SYSTEM (FAWPSS)
LAB 9095 (NSN 4320-01-359-0369)
M105 (NSN 4320-01-532-7057)



* a PART OF ITEM 1

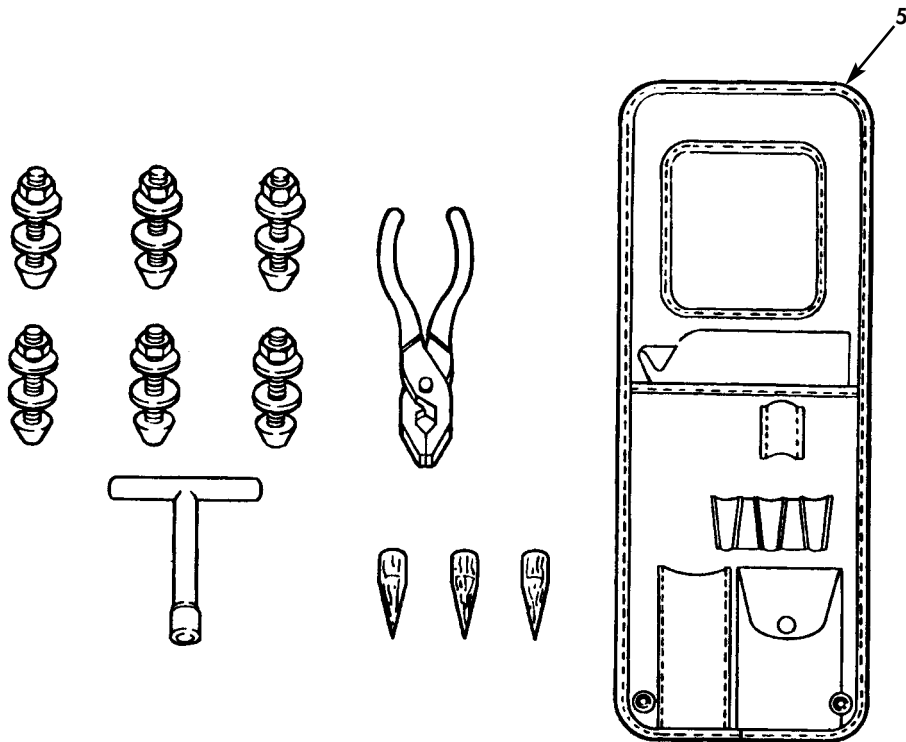

Figure 7. Fabric Drum Assemblies.

(1) ITEM NO	(2) SMR CODE	(3) NSN	(4) CAGEC	(5) PART NUMBER	(6) DESCRIPTION AND USABLE ON CODE (UOC)	(7) QTY
GROUP 0700 FABRIC DRUM ASSEMBLIES						
FIG. 7 FABRIC DRUM ASSEMBLIES						
1	PAOOO	5430-01-527-4514	1YFX5	GTA-500W	TANK,FABRIC,COLLAPS DRINKING WATER, 500 GALLON CAPACITY FOR PARTS BREAKDOWN SEE TM10-5430-247-13&P....	6
1	PAOOO	5430-01-507-2574	05476	91065	TANK,FABRIC,COLLAPS DRINKING WATER, 500 GALLON CAPACITY FOR PARTS BREAKDOWN SEE TM10-5430-245-12&P....	6
2	PAOZZ	5340-01-119-7584	97403	13216E9192	.CAP,PROTECTIVE,DUST.....	1
3	PAOZZ	4930-00-973-2589	81718	77BN-2X1-1/2AL	.VALVE COUPLER.....	2
4	PAOZZ	5330-00-612-2414	58536	AA59326-G6	..GASKET.....	2
5	PAOZZ	8110-00-856-6244	97403	5-14-679-1	.REPAIR KIT,COLLAPSI.....	1

END OF FIGURE

FORWARD AREA WATER POINT SUPPLY SYSTEM (FAWPSS)
LAB 9095 (NSN 4320-01-359-0369)
M105 (NSN 4320-01-532-7057)

1 — 2
thru
6

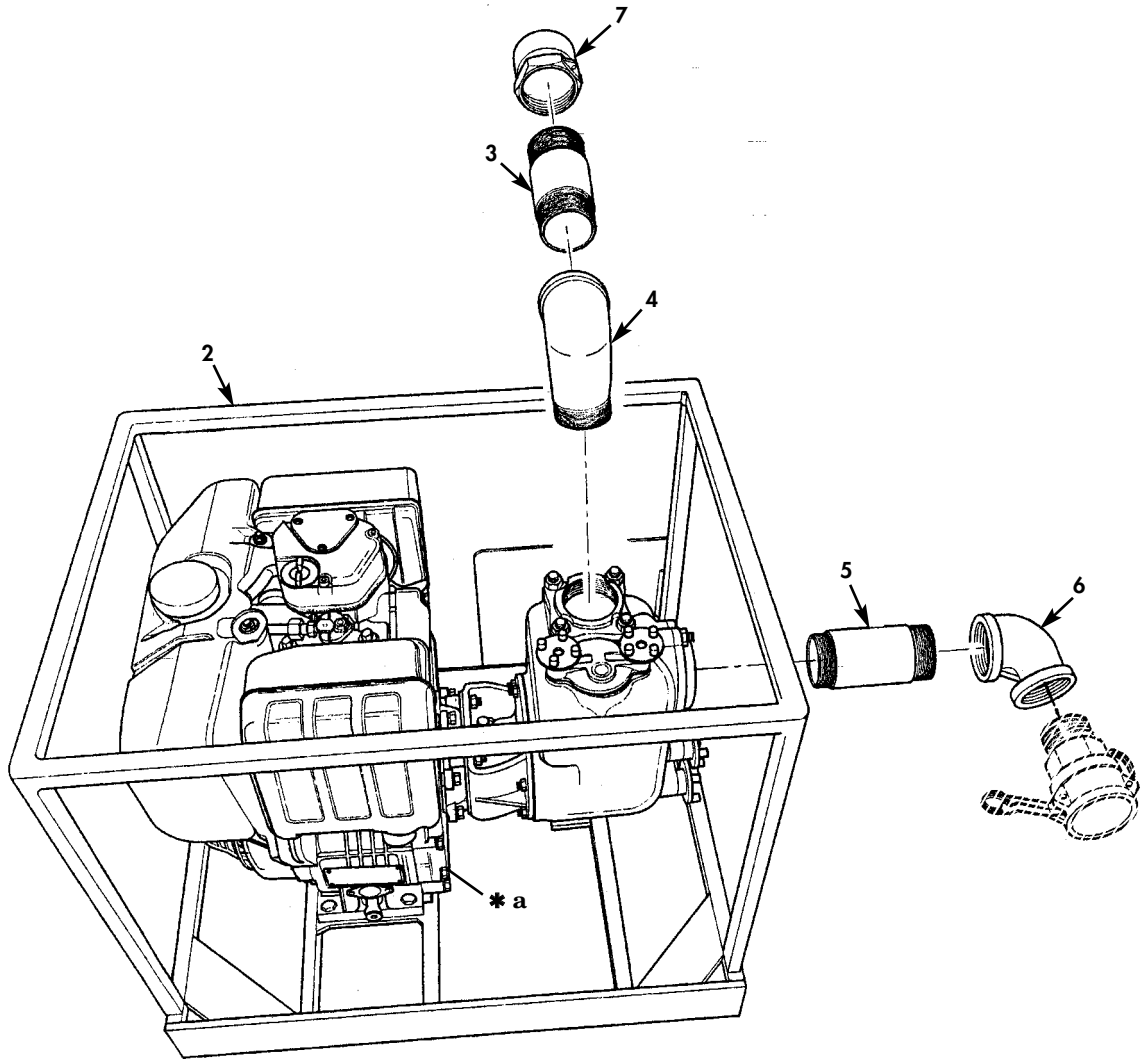

* a PART OF ITEM 1

Figure 8. Pump Units.

(1) ITEM NO	(2) SMR CODE	(3) NSN	(4) CAGEC	(5) PART NUMBER	(6) DESCRIPTION AND USABLE ON CODE (UOC)	(7) QTY
GROUP 0800 PUMP UNITS						
FIG. 8 PUMP UNITS						
1	PAOOO	4320-01-507-0598	3C2U0	56913030	PUMP UNIT,CENTRIFUG FOR PARTS BREAKDOWN SEE TM 5-5430-368-14&P....	2
2	PAOZZ		3C2U0	61726109	.BASE,ENGINE MOUNTIN.....	1
3	PAOZZ		25795	6P869	.NIPPLE,PIPE.....	1
4	PAOZZ		25795	5P827	.ELBOW,PIPE TO HOSE.....	1
5	PAOZZ		25795	6P877	.NIPPLE,PIPE.....	1
6	PAOZZ		25795	5P803	.ELBOW,PIPE TO HOSE.....	1
7	PAOZZ	4730-00-079-1362	96906	MS27020-11	COUPLING HALF,QUICK.....	2

END OF FIGURE

FORWARD AREA WATER POINT SUPPLY SYSTEM (FAWPSS)
LAB 9095 (NSN 4320-01-359-0369)
M105 (NSN 4320-01-532-7057)

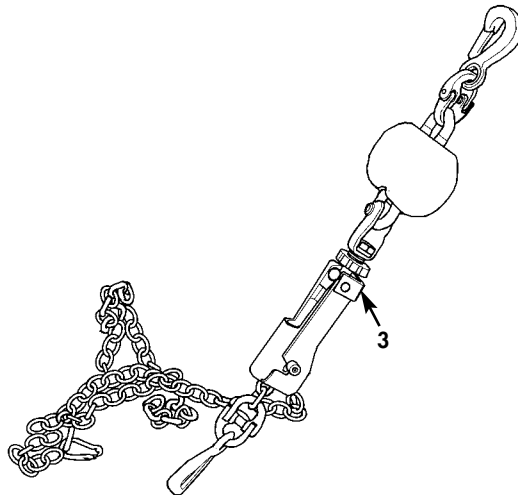
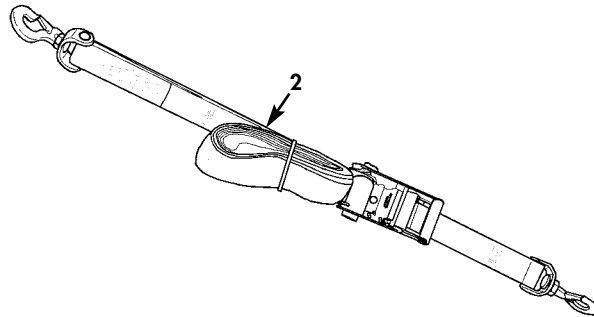
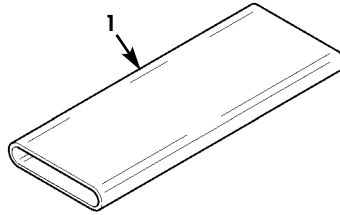

Figure 9. Tiedown Assemblies.

(1) ITEM NO	(2) SMR CODE	(3) NSN	(4) CAGEC	(5) PART NUMBER	(6) DESCRIPTION AND USABLE ON CODE (UOC)	(7) QTY
GROUP 0900 TIEDOWN ASSEMBLIES						
FIG. 9 TIEDOWN ASSEMBLIES						
1	PAOZZ		94658	PH3319-10-2	SLEEVE,PROTECTIVE PART OF KIT P/N 4792/TK-1.....	16
					UOC:MMH	
2	PAOZZ		94658	7MRW/XXXX	TIE DOWN,CARGO,VEHI PART OF KIT P/N 4792/TK-1.....	10
					UOC:MMH	
3	PAOZZ		94658	15MTC/1668D	TIE DOWN,CARGO,VEHI PART OF KIT P/N 4792/TK-1.....	12
					UOC:MMH	
KIT	PAOZZ		94658	4792/TK-1	TIE DOWN KIT.....	1
					UOC:MMH	
					SLEEVE,PROTECTIVE (16)	9-1
					TIE DOWN,CARGO,VEHI(10)	9-2
					TIE DOWN,CARGO,VEHI(12)	9-3

END OF FIGURE

(1) ITEM NO	(2) SMR CODE	(3) NSN	(4) CAGEC	(5) PART NUMBER	(6) DESCRIPTION AND USABLE ON CODE (UOC)	(7) QTY
					GROUP 1000 BULK ITEMS	
					FIG. BULK	
1	PAOZZ	4010-00-515-4101	81349	RR-C-271	CHAIN,WELDLESS STEEL CORROSION RESISTING,TYPE II,CLASS 3.....	V

END OF FIGURE

CROSS REFERENCE INDEXES

NATIONAL STOCK NUMBER INDEX

STOCK NUMBER	FIGURE NO	ITEM NO	STOCK NUMBER	FIGURE NO	ITEM NO
4730-00-079-1362	8	7	6530-01-472-7847	4	2
4730-00-088-9285	2	4	4320-01-507-0598	8	1
5310-00-241-6667	5	12	5430-01-507-2574	7	1
5310-00-245-8826	5	10	5430-01-527-4514	7	1
4820-00-330-5466	2	2			
5330-00-360-0595	1	11			
	3	11			
4010-00-515-4101	BULK	1			
5330-00-612-2414	1	3			
	1	7			
	2	5			
	6	2			
	6	9			
	6	11			
	7	4			
4730-00-649-9100	1	2			
	1	6			
	6	10			
4730-00-649-9103	6	8			
5305-00-723-9387	5	4			
5305-00-727-6804	5	13			
5315-00-812-1236	4	4			
4730-00-823-5316	1	12			
	6	12			
5315-00-839-5820	4	3			
8110-00-856-6243	5	1			
8110-00-856-6244	7	5			
4730-00-869-5246	1	10			
4730-00-915-5127	1	4			
	1	8			
	6	6			
5325-00-926-5411	6	7			
4730-00-938-7997	2	3			
	6	5			
5305-00-941-3579	5	5			
4030-00-948-7315	4	5			
	5	7			
4730-00-951-3295	6	1			
4930-00-973-2589	7	3			
4730-01-009-1735	6	4			
4730-01-068-5070	6	3			
5315-01-105-7350	5	3			
5340-01-119-7584	7	2			
4930-01-120-7426	4	1			
4730-01-126-3825	3	10			
4720-01-163-4683	1	1			
4720-01-174-8173	1	9			
4720-01-175-5957	1	5			
4610-01-188-8197	3	2			
4730-01-189-1233	3	9			
5315-01-258-6496	5	9			
4730-01-317-0694	6	3			
6530-01-472-7843	4	7			

CROSS REFERENCE INDEXES

PART NUMBER INDEX

PART NUMBER	FIGURE NO	ITEM NO	PART NUMBER	FIGURE NO	ITEM NO
110-5	1	11	H-9209-M	3	6
	3	11	H-9210-M	3	5
122HWA0100 1S	3	9	H01434M	6	7
13216E7992	5	6	MIL-Y-40628	5	1
13216E7993	5	2	MS16228-10C	5	10
13216E7994	5	11	MS16228-8C	5	12
13216E7995	5	3	MS20392-3C35	4	4
13216E9192	7	2	MS24665-134	4	3
13225E9095- 12/13/22	3	1	MS27020-11	8	7
13225E9135-1	1	1	MS35307-414	5	13
13225E9136-11	1	9	MS35307-463	5	5
13225E9136-5	1	5	MS51963-63	5	4
13225E9137	2	1	MS87006-33	4	5
13225E9140	4	1		5	7
13225E9145	4	7	PH3319-10-2	9	1
13225E9146	4	2	RR-C-271	BULK	1
15MTC/1668D	9	3	RR-C-271-45	4	6
300ALM-BODY	3	3	RR-C-271-AR	5	8
319-K	6	3	S-127-BR-R-T-2IN	2	2
319K-2	6	3			
33290	5	9			
4792/TK-1	9	KIT			
5-14-679-1	7	5			
56913030	8	1			
5P803	8	6			
5P827	8	4			
61726109	8	2			
633BA-2X1-1/2AL	6	1			
6P869	8	3			
6P877	8	5			
77BN-2X1-1/2AL	7	3			
7MRW/XXXX	9	2			
811-PW	3	2			
91065	7	1			
AA59326-G6	1	3			
	1	7			
	2	5			
	6	2			
	6	9			
	6	11			
	7	4			
AA59326/10-5	1	10			
AA59326A/14-8-A-1	3	10			
AA59326III16	2	3			
	6	5			
AA59326IX16	1	2			
	1	6			
	6	10			
AA59326V16	6	8			
AA59326VII16	2	4			
AA59326X15	1	12			
	6	12			
AA59326X16	1	4			
	1	8			
	6	6			
AA59326XXI15	6	4			
GTA-500W	7	1			
H-3283-M	3	7			
H-9112-M	3	4			
H-9116-AS	3	8			

CHAPTER 8

SUPPORTING INFORMATION FOR FORWARD AREA WATER POINT SUPPLY SYSTEM (FAWPSS)

References	WP 0044
Maintenance Allocation Chart (MAC) Introduction	WP 0045
Maintenance Allocation Chart (MAC)	WP 0046
Components of End Item (COEI) and Basic Issue Items (BII) Lists	WP 0047
Additional Authorization List (AAL)	WP 0048
Expendable and Durable Items List	WP 0049
Illustrated List of Manufactured Items	WP 0050
Torque Limits	WP 0051
Index	INDEX-1

**OPERATOR AND UNIT MAINTENANCE
FORWARD AREA WATER POINT SUPPLY SYSTEM (FAWPSS)
REFERENCES**

SCOPE

This work package lists all field manuals, forms, technical manuals, and miscellaneous publications referenced in this manual.

PUBLICATIONS INDEX

The following index should be consulted frequently for latest changes or revisions and for new publications relating to material covered in this manual.

DA PAM 750-8 The Army Maintenance Management System (TAMMS) Users Manual

FORMS

The following forms pertain to this manual. See DA PAM 25-30 for index of blank forms. See DA PAM 750-8, The Army Maintenance Management System (TAMMS) Users Manual, for instructions on the use of maintenance forms pertaining to this manual.

DA FORM 2028 Recommended Changes to DA Publications and Blank Forms
DA FORM 2402 Exchange Tag
DA FORM 2404/5988-E Equipment Inspection and Maintenance Worksheet
DA FORM 5504 Maintenance Request Form
SF 364 Report of Discrepancy
SF 368 Product Quality Deficiency Report

FIELD MANUALS

FM 4-25.11 First Aid for Soldiers
FM 9-207 Operations and Maintenance of Ordnance Materiel In Cold Weather
FM 31-70 Basic Cold Weather Manual
FM 31-71 Northern Operations

TECHNICAL MANUALS

TM 740-90-1 Administrative Storage of Equipment
TM 750-244-3 Procedures for Destruction of Equipment to Prevent Enemy Use (Mobility Equipment Command)
TM 734-200-1 Storage and Materials Handling
TM 740-90-1 Administrative Storage of Equipment
TM 55-2200-001-12 Transportability Guidance for Application of Blocking, Bracing, and Tiedown Materials
TM 9-2320-279-10 Operator's Manual for M977 Series, 8x8 Heavy Expanded Mobility Tactical Trucks (HEMTT)
TM 746-10 Marking, Packing, and Shipment of Supplies and Equipment
TM 9-3990-206-14&P Operator, Unit, Direct Support, and General support Maintenance Manual (Including Repair Parts and Special Tools List) for Palletized Load System (PLS) Flatrack

REFERENCES (Contd)**TECHNICAL MANUALS (Contd)**

TM 9-3990-260-14&P	Operator, Unit, Direct Support, and General support Maintenance Manual (Including Repair Parts and Special Tools List) for Container Roll-In/Roll-Out Platform (CROP)
TM 10-5430-245-12&P	Operator's and Unit Maintenance Manual (Including Repair Parts and Special Tools List) for Drum, Fabric, Collapsible, Drinking Water, 500 Gallon Capacity, Model 91065
TM 10-5430-247-13&P	Operator's and Field Level Maintenance Manual with Field Level Maintenance Repair Parts and Special Tools List (Including Unit and DS Repair Parts) for Drum, Fabric, Collapsible, Drinking Water, 500 Gallon capacity, Model GTA500W
TM 5-4320-368-14&P	Operator, Unit, Direct Support, and General Support Maintenance Manual (Including Repair Parts and Special Tools List) for Pump Unit, Centrifugal, Diesel-Driven, Self-Priming

MISCELLANEOUS PUBLICATIONS

MIL-STD-12	Abbreviations for Use on Drawings, and Standards, Specifications, and Technical Documents
CTA 8-100	Army Medical Department Expendable/Durable Items
CTA 50-970	Expendable Items (Except Medical Class V, Repair Parts and Heraldic Items)
TB MED 577	Sanitary Control and Surveillance of Field Water Supplies

**OPERATOR AND UNIT MAINTENANCE
FORWARD AREA WATER POINT SUPPLY SYSTEM (FAWPSS)
MAINTENANCE ALLOCATION CHART (MAC) INTRODUCTION**

THE ARMY MAINTENANCE SYSTEM (AMS)

This introduction provides a general explanation of all maintenance and repair functions authorized at the two maintenance levels under the Two-Level Maintenance System concept.

The Maintenance Allocation Chart (MAC) (WP 0046) designates overall authority and responsibility for the performance of maintenance functions on the identified end item or component. The application of the maintenance functions to the end item or component shall be consistent with the capacities and capabilities of the designated maintenance levels, which are shown on the MAC in column (4) as:

Field Level (Tactical)-C (operator/crew), O (unit) maintenance, and F (Direct Support).

Field Maintenance is on-system maintenance and is mainly replacement of defective parts and preventative maintenance. Field maintenance returns repaired equipment to operation. It covers crew, unit, and selected DS maintenance tasks. Some "off-system" maintenance can be done at field level if, based on task analysis, it is simple to complete or it is critical to mission readiness.

Sustainment Level (Sustainment)-H (General Support) and D (Depot).

Sustainment is off-system maintenance and is mainly repair of defective or worn out equipment/parts. Sustainment maintenance returns repaired equipment/parts to the supply system. It covers selected DS tasks, GS, and Depot maintenance.

The tools and test equipment requirements (immediately following the MAC) list the tools and test equipment (both special tools and common tool sets) required for each maintenance function as referenced from the MAC.

The remarks (immediately following the tools and test equipment requirements) contain supplemental instructions and explanatory notes for a particular maintenance function.

MAINTENANCE FUNCTIONS

Maintenance functions are limited to and defined as follows:

1. **Inspect** — To determine the serviceability of an item by comparing its physical, mechanical, and/or electrical characteristics with established standards through examination (e.g., by sight, sound, or feel). This includes scheduled inspection and gagings and evaluation of cannon tubes.
2. **Test** — To verify serviceability by measuring the mechanical, pneumatic, hydraulic, or electrical characteristics of an item and comparing those characteristics with prescribed standards on a scheduled basis, i.e., load testing of lift devices and hydrostatic testing of pressure hoses.
3. **Service** — Operations required periodically to keep an item in proper operating condition; i.e., to clean (includes decontaminate, when required), to preserve, to drain, to paint, or to replenish fuel, lubricants, chemical fluids, or gases. This includes scheduled exercising and purging of recoil mechanisms. The following are examples of service functions:
 - a. **Unpack** — To remove from packing box for service or when required for the performance of maintenance operations.
 - b. **Repack** — To return item to packing box after service and other maintenance operations.
 - c. **Clean** — To rid the item of contamination.
 - d. **Touch up** — To spot paint scratched or blistered surfaces.
 - e. **Mark** — To restore obliterated identification.
4. **Adjust** — To maintain or regulate, within prescribed limits, by bringing into proper position, or by setting the operating characteristics to specified parameters.
5. **Align.** — To adjust specified variable elements of an item to bring about optimum or desired performance.

MAINTENANCE ALLOCATION CHART (MAC) INTRODUCTION (Contd)**MAINTENANCE FUNCTIONS (Contd)**

6. **Calibrate** — To determine and cause corrections to be made or to be adjusted on instruments or test, measuring, and diagnostic equipment used in precision measurement. Consists of comparisons of two instruments, one of which is a certified standard of known accuracy, to detect and adjust any discrepancy in the accuracy of the instrument being compared.
7. **Remove/Install** — To remove and install the same item when required to perform service or other maintenance functions. Install may be the act of emplacing, seating, or fixing into position a spare, repair part, or module (component or assembly) in a manner to allow the proper functioning of an equipment or system.
8. **Paint** — To prepare and spray coats of paint so that the ammunition can be identified and protected. The color indicating primary use is applied, preferably, to the entire exterior surface as the background color of the item. Other markings are to be repainted as original so as to retain proper ammunition identification.
9. **Replace** — To remove an unserviceable item and install a serviceable counterpart in its place. "Replace" is authorized by the MAC and assigned maintenance level is shown as the third position code of the Source, Maintenance and Recoverability (SMR) code.
10. **Repair** — The application of maintenance services, including fault location/troubleshooting, removal/installation, disassembly/assembly procedures and maintenance actions to identify troubles and restore serviceability to an item by correcting specific damage, fault, malfunction, or failure in a part, subassembly, module (component of assembly), end item, or system.

NOTE

The following definitions are applicable to the repair maintenance function:

Services — Inspect, test, service, adjust, align, calibrate, and/or replace.

Fault location/troubleshooting — The process of investigating and detecting the cause of equipment malfunctioning; the act of isolating a fault within a system or Unit Under Test (UUT).

Disassembly/assembly — The step-by-step breakdown (taking apart) of a spare/functional group coded item to the level of its least component, that is assigned an SMR code for the level of maintenance under consideration (i.e., identified as maintenance significant).

Actions — Welding, grinding, riveting, straightening, facing, machining, and/or resurfacing.

11. **Overhaul** — That maintenance effort (service/action) prescribed to restore an item to a completely serviceable/operational condition as required by maintenance standards in appropriate technical publications. Overhaul is normally the highest degree of maintenance performed by the Army. Overhaul does not normally return an item to like-new condition.
12. **Rebuild** — Consists of those services/actions necessary for the restoration of unserviceable equipment to a like-new condition in accordance with original manufacturing standards. Rebuild is the highest degree of materiel maintenance applied to Army equipment. The rebuild operation includes the act of returning to zero those age measurements (e.g., hours/miles) considered in classifying Army equipment/components.

MAINTENANCE ALLOCATION CHART (MAC) INTRODUCTION (Contd)**EXPLANATION OF COLUMNS IN THE MAC**

Column (1) — Group Number. Column (1) lists Functional Group Code (FGC) numbers, the purpose of which is to identify maintenance significant components, assemblies, subassemblies, and modules with the Next Higher Assembly (NHA).

Column (2) — Component/ Assembly. Column (2) contains the item names of components, assemblies, subassemblies, and modules for which maintenance is authorized.

Column (3) — Maintenance Function. Column (3) lists the functions to be performed on the item listed in column (2). (For detailed explanation of these functions refer to Maintenance Functions outlined above.)

Column (4) — Maintenance Level. Column (4) specifies each level of maintenance authorized to perform each function listed in column (3), by indicating work-time required (expressed as man-hours in whole hours or decimals) in the appropriate subcolumn. This work-time figure represents the active time required to perform that maintenance function at the indicated level of maintenance. If the number or complexity of the tasks within the listed maintenance function varies at different maintenance levels, appropriate work time figures are shown for each level. The work time figure represents the average time required to restore an item (assembly, subassembly, component, module, end item, or system) to a serviceable condition under typical field operating conditions. This time includes preparation time (including any necessary disassembly/assembly time), troubleshooting/fault location time, and quality assurance time in addition to the time required to perform the specific tasks identified for the maintenance functions authorized in the MAC.

Field:

- C Operator or Crew maintenance
- O Unit maintenance
- F Direct Support maintenance

Sustainment:

- L Specialized Repair Activity
- H General Support maintenance
- D Depot maintenance

NOTE

The "L" maintenance level is not included in Column 4 of the MAC. Functions to this level of maintenance are identified by a work time figure in the "H" column of Column 4, and an associated reference code is used in the REMARKS Column 6. This code is keyed to the remarks and the SRA complete repair application is explained there.

Column (5) — Tools and Equipment Reference Code. Column (5) specifies, by code, those common tool sets (not individual tools), common Test, Measurement and Diagnostic Equipment (TMDE), and special tools, special TMDE, and special support equipment required to perform the designated function. Codes are keyed to the entries in the tools and test equipment table.

Column (6) — Remarks Code. When applicable this column contains a letter code, in alphabetic order, which is keyed to the remarks table entries.

END OF WORK PACKAGE

**OPERATOR AND UNIT MAINTENANCE
FORWARD AREA WATER POINT SUPPLY SYSTEM (FAWPSS)
MAINTENANCE ALLOCATION CHART (MAC)**

Table 1. Maintenance Allocation Chart (MAC) for FAWPSS.

(1) GROUP NO.	(2) COMPONENT/ASSEMBLY	(3) MAINTENANCE FUNCTION	(4) MAINTENANCE LEVEL					(5) TOOLS AND EQUIPMENT REF. CODE	(6) REMARKS
			FIELD		SUSTAINMENT				
			UNIT		DS	GS	DEPOT		
			C	O	F	H	D		
01	Hose Assemblies	Inspect	0.2						
		Replace	0.2					A	
02	Ball Valve Assemblies	Inspect	0.2						
		Replace	0.2					A	
03	Nozzle Assemblies	Inspect	0.2						
		Replace	0.3					A	
		Repair		1.0			1, 2		
04	Nozzle Stand Assemblies	Inspect	0.2						
		Replace	0.3					A	
		Repair		1.0			1		
05	Towing and Lifting Yoke	Inspect	0.2						
		Replace	0.3					A	
		Repair		1.0			1		
06	Miscellaneous Fittings	Inspect	0.2						
		Replace	0.3					A	
		Repair		0.4				B C	
07	Fabric Drums								
08	Pump Unit							D	
09	Tiedown Components	Inspect	0.2						
		Replace	0.2					A	

Table 2. Tools and Test Equipment for FAWPSS.

(1) REF. TOOL CODE	(2) MAINT. LEVEL	(3) NOMENCLATURE	(4) NATIONAL/NATO STOCK NUMBER	(5) TOOL NUMBER
		NOTE		
		Standard tools and test equipment contained in the following kits are adequate to perform all FAWPSS maintenance functions.		
1	O	Tool Kit, General Mechanic's	5180-00-177-7033	SC5180-90-CL-N26 (19099)
2	O	Shop Equipment, Automotive Maintenance Repair; Organizational Maintenance	4910-00-754-0654	SC 4910-95-CL-A74-HR (19099)

MAINTENANCE ALLOCATION CHART (Contd)

Table 3. Remarks for FAWPSS.

REMARKS CODE	REMARKS
A	Operator replacement consists of removal and installation of component.
B	Repair of miscellaneous components is limited to the replacement of caps, gaskets, and retaining rings.
C	Refer to technical manual TM 5-5430-245-12&P or TM 5-5430-247-13&P for maintenance of fabric drum assemblies.
D	Refer to technical manual TM 5-4320-368-14&P.

END OF WORK PACKAGE

**OPERATOR AND UNIT MAINTENANCE
FORWARD AREA WATER POINT SUPPLY SYSTEM (FAWPSS)
COMPONENTS OF END ITEM (COEI) AND BASIC ISSUE ITEMS (BII) LISTS**

INTRODUCTION**SCOPE**

This work package lists Components of the End Item (COEI) and Basic Issue Items (BII) for the FAWPSS to help inventory items required for safe and efficient operation of the equipment. For a list of COEI and BII for the Pump Unit, refer to TM 5-4320-368-14&P. For a list of COEI and BII for the Drum, refer to TM 10-5430-245-12&P or TM 10-5430-247-13&P.

GENERAL

The COEI and BII lists are divided into the following lists:

Components of End Item (COEI). This listing is for informational purposes only, and is not authority to requisition replacements. These items are part of the end item, but are removed and separately packaged for transportation or shipment. As part of the end item, these items must be with the end item whenever it is issued or transferred between property accounts. Illustrations are furnished to assist you in identifying the items.

Basic Issue Items (BII). These are the minimum essential items required to place the FAWPSS in operation. The illustrations will assist you with hard-to-identify items. This manual is your authority to request/requisition replacement BII, based on Table of Organization and Equipment/Modified Table of Organization and Equipment (TOE/MTOE) authorization of the end item.

EXPLANATION OF COLUMNS

The following provides an explanation of columns found in COEI and BII tables:

- a. **Column (1) — Illustration Number (Illus Number).** This column indicates the number of the illustration in which the item is shown.
- b. **Column (2) — National Stock Number.** Indicates the national stock number assigned to the item and will be used for requisitioning purposes.
- c. **Column (3) — Description.** Indicates the Federal item name and, if required, a minimum description to identify and locate the item. The last line for each item indicates the Commercial and Government Entity Code for Manufacturer (CAGEC) for (in parentheses), followed by a part number.
- d. **Column (4) — Usable On Code.** When the item is unique to one or more models or quantity required differs between models, the applicable Usable On Code is listed in column (4) indicating the item only applies to the code or codes listed. Codes for the FAWPSS are listed below.

<u>Code</u>	<u>Used On</u>
FFV	LAB 9095
FNQ	JGB-FAWPSS-432034612P
MMH	M105

- e. **Column (5) — Unit of Issue (U/I).** Indicates the physical measurement or count of the item as issued per the NSN shown in column (2). The U/I is expressed by a two-character alphabetical abbreviation (e.g.: ea, in., pr).
- f. **Column (6) — Quantity Required (Qty Rqr).** Indicates the quantity of the item authorized to be used with/on the FAWPSS.

COMPONENTS OF END ITEM (COEI) AND BASIC ISSUE ITEMS (BI) LISTS (Contd)

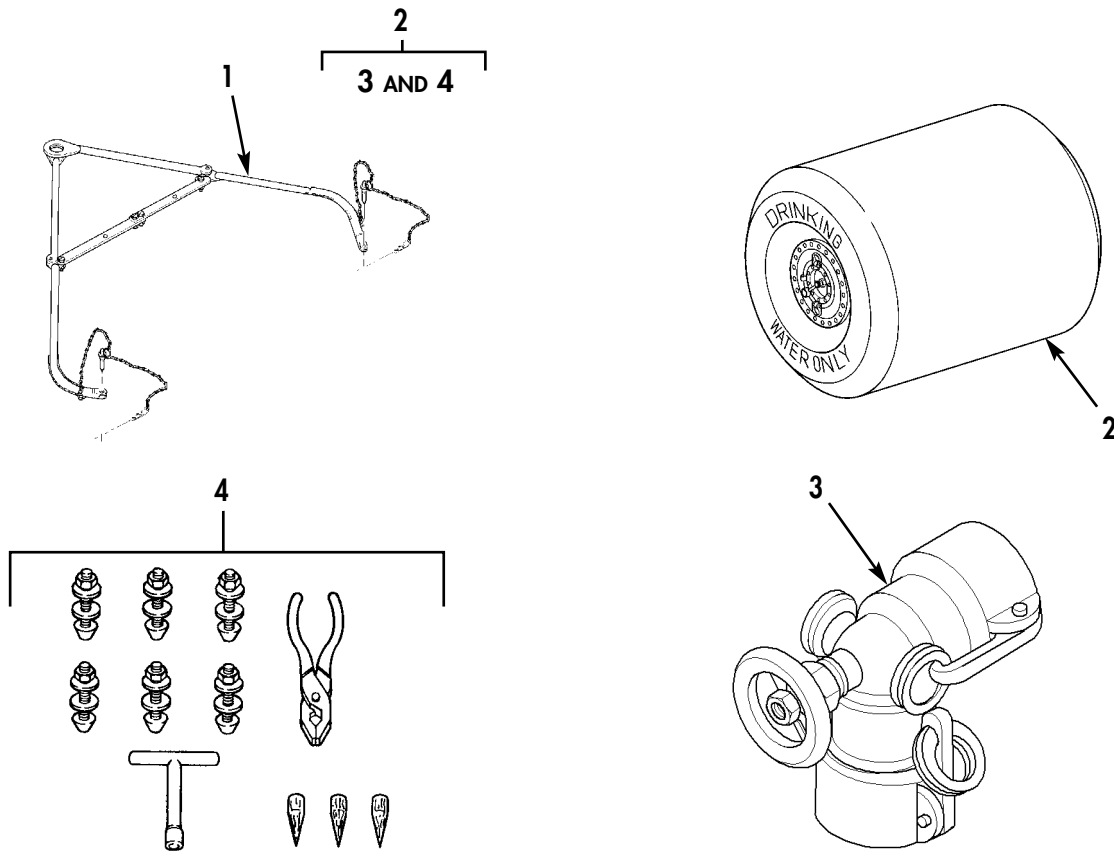

Table 1. Components of End Item List.

(1) ILLUS NUMBER	(2) NATIONAL STOCK NUMBER (NSN)	(3) DESCRIPTION PART NUMBER AND CAGEC	USABLE ON CODE	(4) U/I	(5) QUANTITY REQUIRED
1	8110-00-856-6243	YOKE, TOWING AND LIFTING MIL-Y-40628 (81349)	FFV FNQ	EA	1
2	5430-01-527-4514	TANK, FABRIC, COLLAPSIBLE GTA-500W (1YFX5)	FFV FNQ	EA	6
2	5430-01-527-4514	TANK, FABRIC, COLLAPSIBLE GTA-500W (1YFX5)	MMH	EA	3
2	5430-01-507-2574	TANK FABRIC, COLLAPSIBLE 91065 (05476)	FFV FNQ	EA	6
2	5430-01-507-2574	TANK FABRIC, COLLAPSIBLE 91065 (05476)	MMH	EA	3
3	4930-00-973-2589	VALVE COUPLER 77BN-2X1-1/2 AL (81718)	FFV FNQ	EA	12
3	4930-00-973-2589	VALVE COUPLER 77BN-2X1-1/2 AL (81718)	MMH	EA	6
4	8110-00-856-6244	REPAIR KIT 5-14-679-1 (97403)	FFV FNQ	EA	6
4	8110-00-856-6244	REPAIR KIT 5-14-679-1 (97403)	MMH	EA	3

COMPONENTS OF END ITEM (COEI) AND BASIC ISSUE ITEMS (BI) LISTS (Contd)

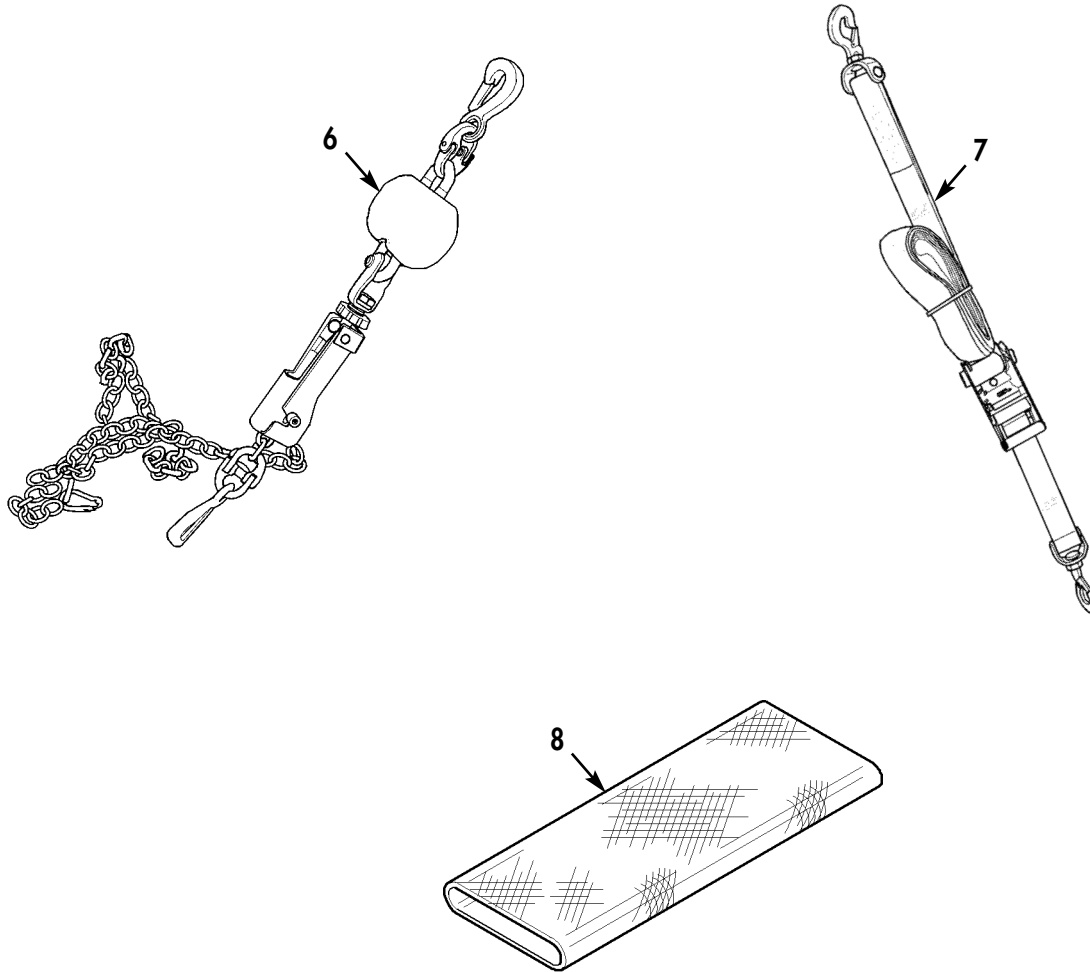
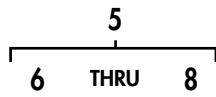

Table 1. Components of End Item List (Contd).

(1) ILLUS NUMBER	(2) NATIONAL STOCK NUMBER	(3) DESCRIPTION CAGEC AND PART NUMBER	USABLE ON CODE	(4) U/I	(5) QUANTITY REQUIRED
5		DRUM TIEDOWN KIT 15MTC/1668A (97403)	MMH	EA	1
6		TIEDOWN ASSEMBLY, tensioner; 9/32 chain size 15 MTC/1668D (94658)	MMH	EA	12
7		TIEDOWN ASSEMBLY, ratchet, polyester webbing 7MRW/XXXX (94658)	MMH	EA	10
8		PROTECTIVE SLEEVE, nylon PH3319-10-2 (94658)	MMH	EA	16

COMPONENTS OF END ITEM (COEI) AND BASIC ISSUE ITEMS (BI) LISTS (Contd)

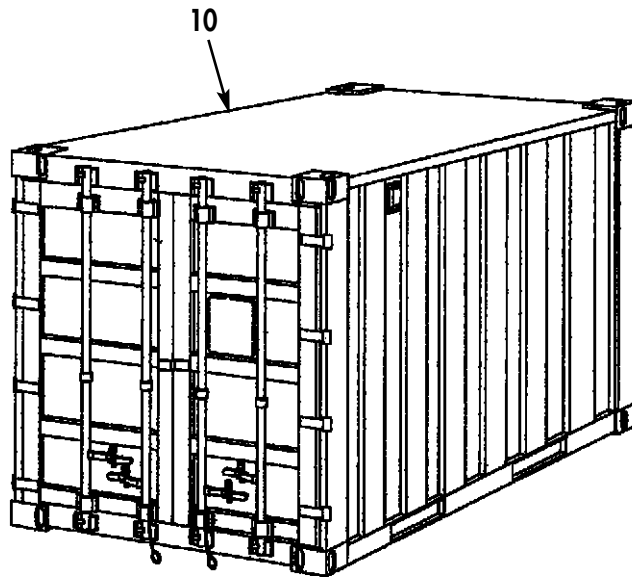
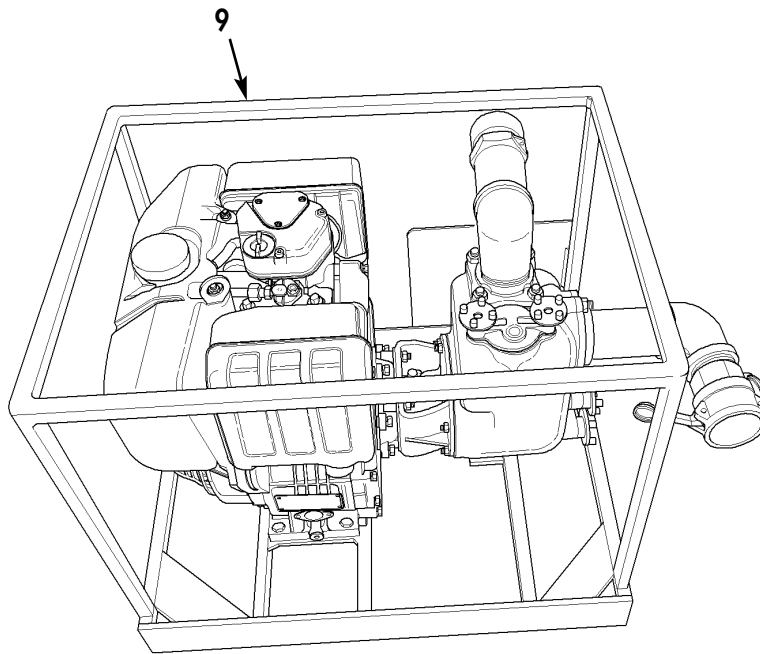

Table 1. Components of End Item List (Contd).

(1) ILLUS NUMBER	(2) NATIONAL STOCK NUMBER (NSN)	(3) DESCRIPTION PART NUMBER AND CAGEC	USABLE ON CODE	(4) U/I	(5) QUANTITY REQUIRED
9	4320-01-507-0598	PUMP UNIT, CENTRIFUGAL 56913030 (3C2UO)		EA	1
10	8145-01-475-9570	TRICON, CONTAINER, CARGO ATPD2298 (19207)		EA	1

COMPONENTS OF END ITEM (COEI) AND BASIC ISSUE ITEMS (BII) LISTS (Contd)

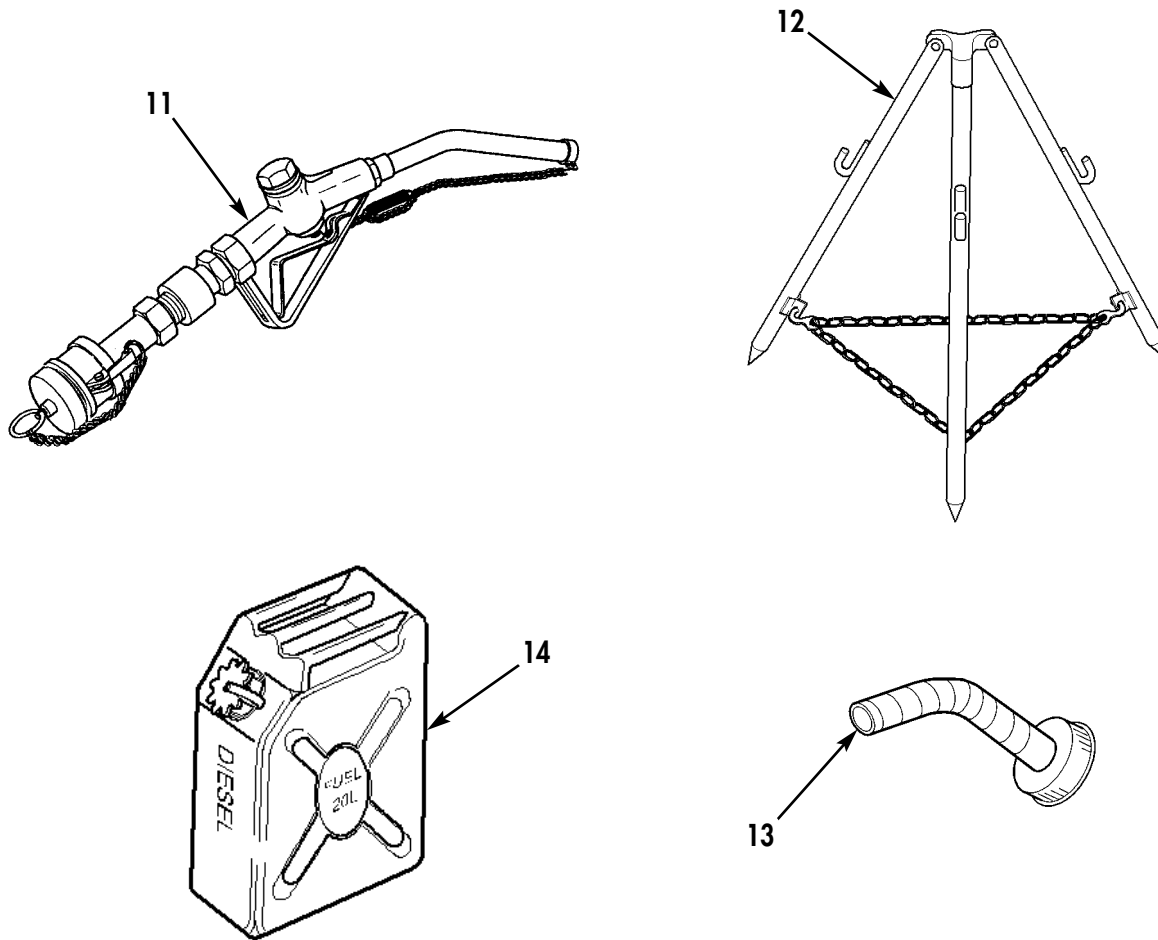

Table 1. Components of End Item List (Contd).

(1) ILLUS NUMBER	(2) NATIONAL STOCK NUMBER (NSN)	(3) DESCRIPTION PART NUMBER AND CAGEC	USABLE ON CODE	(4) U/I	(5) QUANTITY REQUIRED
11	4610-01-188-8197	NOZZLE, WATER DISTRIBUTION 811-PW (81718)		EA	4
12	4930-01-120-7426	STAND ASSEMBLY, DISTRIBUTION 13225E9140 (97403)		EA	2
13	7240-00-177-6154	SPOUT, CAN, FLEXIBLE 13225E9094-2 (19207)		EA	1
14	7420-01-337-5268	CAN, GASOLINE, MILITARY CID A-A-59592 (81349)		EA	2

COMPONENTS OF END ITEM (COEI) AND BASIC ISSUE ITEMS (BI) LISTS (Contd)

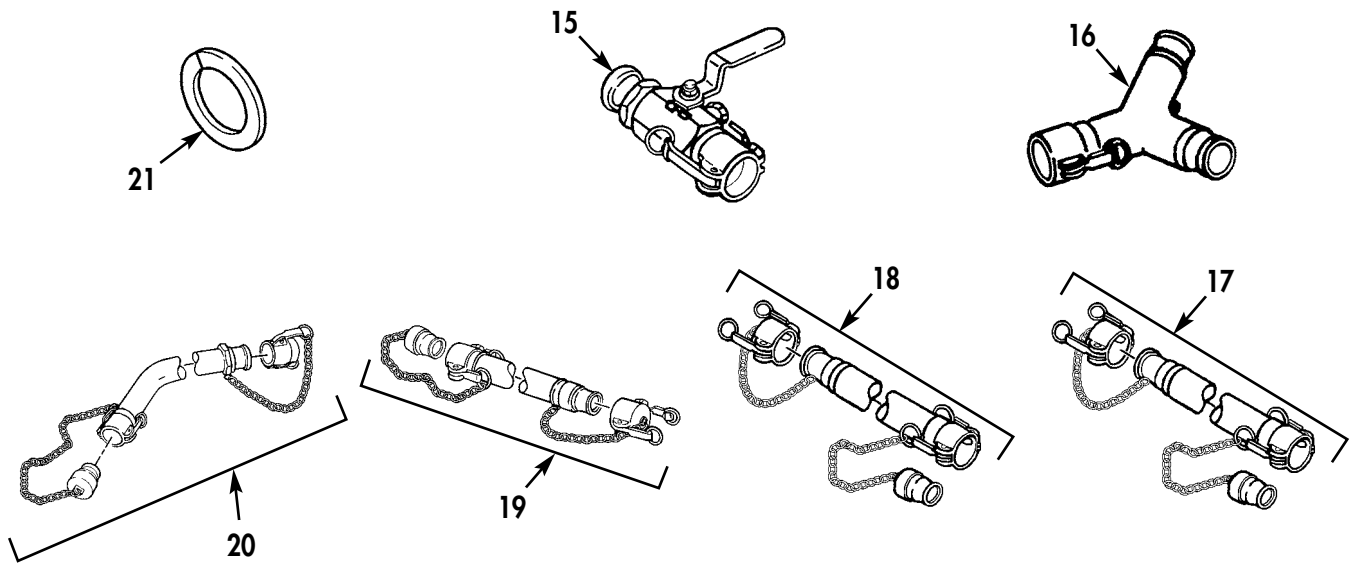

Table 1. Components of End Item List (Contd).

(1) ILLUS NUMBER	(2) NATIONAL STOCK NUMBER (NSN)	(3) DESCRIPTION PART NUMBER AND CAGEC	USABLE ON CODE	(4) U/I	(5) QUANTITY REQUIRED
15	4820-00-330-5466	VALVE, BALL 13225E9137-2 (97403)	FFV FNQ	EA	2
15	4820-00-330-5466	VALVE, BALL 13225E9137-2 (97403)	MMH	EA	3
16	4730-01-068-5070	WYE, QUICK-DISCONNECT 319K (OU9Z1)	FFV FNQ	EA	4
16	4730-01-068-5070	WYE, QUICK-DISCONNECT 319K-2 (81718)	MMH	EA	5
17	4720-01-163-4683	HOSE ASSEMBLY, SUCTION, 2"x10' 13225E9135-1 (97403)	FFV FNQ	EA	3
17	4720-01-163-4683	HOSE ASSEMBLY, SUCTION, 2"x10' 13225E9135-1 (97403)	MMH	EA	4
18	4720-01-163-5088	HOSE ASSEMBLY, DISCHARGE 2"x10' 13225E9136-1 (97403)		EA	1
19	4720-01-175-5957	HOSE ASSEMBLY, DISCHARGE, 2"x25' 13225E9136-5 (97403)		EA	2
20	4720-01-174-8173	HOSE ASSEMBLY, DISCHARGE, 1.5"x25' 13225E9136-11 (97403)		EA	4
21	5325-00-926-5411	RING, RETAINING, H01434M (81718)	MMH	EA	15

COMPONENTS OF END ITEM (COEI) AND BASIC ISSUE ITEMS (BII) LISTS (Contd)

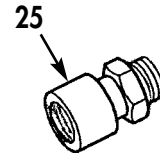
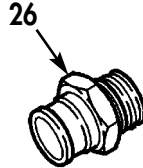
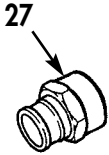
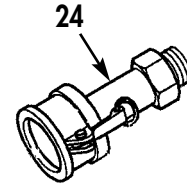
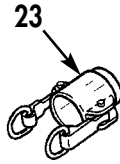
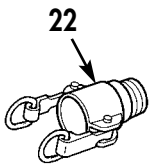

Table 1. Components of End Item List (Contd).

(1) ILLUS NUMBER	(2) NATIONAL STOCK NUMBER (NSN)	(3) DESCRIPTION PART NUMBER AND CAGEC	USABLE ON CODE	(4) U/I	(5) QUANTITY REQUIRED
22	4730-00-088-9285	COUPLING HALF, QUICK-DISCONNECT A-A-59326/7 (58536)	FFV FNQ	EA	1
22	4730-00-088-9285	COUPLING HALF, QUICK-DISCONNECT A-A-59326/7 (58536)	MMH	EA	4
23	4730-00-649-9103	COUPLING HALF, QUICK-DISCONNECT AA59326V16 (58536)		EA	1
24	4730-01-126-3825	COUPLING HALF, QUICK-DISCONNECT AA59326A/14A/14-8-A-1 (58536)		EA	4
25	4730-01-189-1233	SWIVEL JOINT, PIPE 122HWA01001S (41592)		EA	4
26	4730-00-938-7997	COUPLING HALF, QUICK-DISCONNECT A-A-59326III16 (58536)		EA	1
27	4730-00-079-1362	COUPLING HALF, QUICK-DISCONNECT M527020-11 (96906)		EA	1

COMPONENTS OF END ITEM (COEI) AND BASIC ISSUE ITEMS (BI) LISTS (Contd)

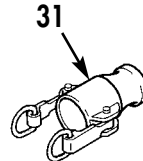
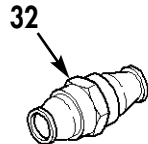
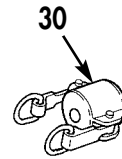
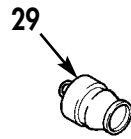
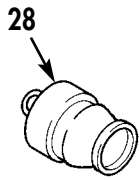

Table 1. Components of End Item List (Contd).

(1) ILLUS NUMBER	(2) NATIONAL STOCK NUMBER (NSN)	(3) DESCRIPTION PART NUMBER AND CAGEC	USABLE ON CODE	(4) U/I	(5) QUANTITY REQUIRED
28	4730-00-915-5127	PLUG, QUICK-DISCONNECT AA593226X16 (58536)	FFV FNQ	EA	1
28	4730-00-915-5127	PLUG, QUICK-DISCONNECT AA59326X16 (58536)	MMH	EA	4
29	4730-00-823-5316	PLUG, QUICK-DISCONNECT AA59326X15 (58536)		EA	4
30	4730-00-649-9100	CAP, QUICK-DISCONNECT AA59326IX16 (58536)	FFV FNQ	EA	1
30	4730-00-649-9100	CAP, QUICK-DISCONNECT AA59326IX16 (58536)	MMH	EA	7
31	4730-00-951-3295	REDUCER, QUICK-DISCONNECT 633BA-2X1-1/2AL (81718)		EA	4
32	4730-01-009-1735	NIPPLE, QUICK-DISCONNECT AA59326XXI15 (58536)		EA	1

COMPONENTS OF END ITEM (COEI) AND BASIC ISSUE ITEMS (BII) LISTS (Contd)

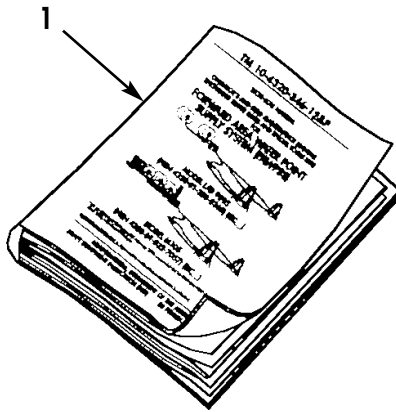

Table 2. Basic Issue Items (BII).

(1) ILLUS NUMBER	(2) NATIONAL STOCK NUMBER (NSN)	(3) DESCRIPTION PART NUMBER AND CAGEC	USABLE ON CODE	(4) U/I	(5) QUANTITY REQUIRED
1	TM-10-4320-346-12&P	MANUAL, TECHNICAL, OPERATOR, UNIT MAINT, & PARTS for FAWPSS		EA	1

**OPERATOR AND UNIT MAINTENANCE
FORWARD AREA WATER POINT SUPPLY SYSTEM (FAWPSS)
ADDITIONAL AUTHORIZATION LIST (AAL)**

INTRODUCTION**SCOPE**

This work package lists additional items authorized for the support of the FAWPSS.

GENERAL

This lists identifies items that do not have to accompany the FAWPSS and that do not have to be turned in with it. These items are authorized by CTA, MTOE, or JTA.

EXPLANATION OF COLUMNS IN THE AAL

Column (1)—National Stock Number (NSN). Identifies the stock number of the item to be used for requisitioning purposes.

Column (2)—Description, Part Number, and Commercial and Government Entity Code (CAGEC). Identifies the Federal item name (in all capital letters) followed by a minimum description when needed. The last line below the description is the part number and CAGEC in parentheses.

Column (3)—Usable On Code. When the item is unique to one or more models, the applicable Usable On Code is listed in column (3) indicating the item only applies to the code or codes listed. Codes for the FAWPSS are identified below:

<u>Code</u>	<u>Used On</u>
FFV	LAB 9095
FNQ	JGB-FAWPSS-432034612P
MMH	M105

Column (4)—Unit of Measure (U/I). Indicates the physical measurement or count of the item as issued per the National Stock Number shown in column (1). The U/I is expressed by a two-character alphabetical abbreviation (e.g.: ea, in., pr).

Column (5)—Qty Recm. Indicates the quantity recommended.

ADDITIONAL AUTHORIZATION LIST (Contd)

Table 1. Additional Authorization List (AAL).

(1) NATIONAL STOCK NUMBER	(2) DESCRIPTION CAGEC & PART NUMBER	(3) USABLE ON CODE	(4) U/I	(5) QTY RECM
8110-00-856-6243	YOKE, TOWING AND LIFTING 13216E7991 (97403)	MMH	EA	1

END OF WORK PACKAGE

**OPERATOR AND UNIT MAINTENANCE
FORWARD AREA WATER POINT SUPPLY SYSTEM (FAWPSS)
EXPENDABLE AND DURABLE ITEMS**

INTRODUCTION

SCOPE

This listing is for informational purposes only and is not authority to requisition the listed items. These items are authorized by CTA 50-970, Expendable/Durable Items (except medical, class V, repair parts, and heraldic items).

EXPLANATION OF COLUMNS

- a. Column (1)—Item Number.** This number is assigned to the entry in the listing and is referenced in the narrative instructions to identify the item
(e.g.: cleaning solvent compound, item 3, WP 0049).
- b. Column (2)—Level.** This column identifies the lowest level of maintenance that requires the listed item.

C—Operator/Crew
O—Unit Maintenance
- c. Column (3)—National Stock Number (NSN).** This is the National Stock Number assigned to the item; use it to request or requisition the item.
- d. Column (4)—Item Name, Description, Part Number and CAGEC.** This column indicates the Federal item name and, if required, a description to identify the item. The last line for each item indicates the part number followed by the Commercial and Government Entity Code for Manufacturer (CAGEC) in parentheses.
- e. Column (5)—Unit of Issue (U/I).** Indicates the physical measurement or count of the item as issued per the NSN shown in column (3). The U/I is expressed by a two character alphabetical abbreviation (e.g.: ea, in., pr).

EXPENDABLE AND DURABLE ITEMS (Contd)

Table 1. Expendable and Durable Items List.

(1) ITEM NO.	(2) LEVEL	(3) NATIONAL STOCK NUMBER (NSN)	(4) ITEM NAME, DESCRIPTION PART NUMBER/(CAGEC)	(5) U/I
1	0	7920-00-044-9281	CLOTH, CLEANING: General purpose; White; A-A-59323 (58536) 10-Pound Box	LB
2	0	7920-00-018-3581	BRUSH, CLEANING, TOOL AND PARTS 7226T2 (39428)	EA
3	0	6850-01-381-4423	CLEANING COMPOUND: Solvent; SKYSOL 100 (OK209) 5-Gallon Can	GAL
4	0	8030-00-252-3391	SEALING COMPOUND: Paste; 11 Ounce Tube; MIL-S-45180, Type (81349) FORMAGASKET 2 (62377)	OZ
5	0	7930-00-282-9699	DETERGENT, GENERAL PURPOSE: Liquified; 7930-00-282-9699 (83421) 1-Gallon Can	GAL
6	0	8030-00-889-3535	TAPE, ANTISEIZING: Size 2; 417043-2 (96214)	EA
7	0	8030-00-223-3193	Corrosion preventive compound: Grade II, Soft Film MIL-C-16173 (81349) 1-Gallon Can	GAL
8	0	5975-00-899-4606	Strap, Tiedown Electrical Components, polyamide nylon, self locking, black color 1 Hundred (81343) MS3367-2-0	BOX
9	0	6810-00-598-7316	Solution, Sodiumhypochlorite (1H4F2) purebright germicidal bleach	BOX

END OF WORK PACKAGE

**UNIT MAINTENANCE
FORWARD AREA WATER POINT SUPPLY SYSTEM (FAWPSS)
ILLUSTRATED LIST OF MANUFACTURED ITEMS**

SCOPE

This work package includes complete instructions for making items authorized to be manufactured or fabricated at unit maintenance level.

HOW TO USE THE INDEX OF MANUFACTURED ITEMS

A part number index in alphanumeric order is provided for cross-referencing the part number of the item to be manufactured to the page which covers fabrication criteria.

EXPLANATION OF THE ILLUSTRATIONS OF MANUFACTURED ITEMS

Instructions to manufacture the item are provided in procedural form below each illustration. All bulk materials required for manufacture of an item are listed by part number or specification number within the procedure, and in Table 1, Manufactured Items Part Number Index.

For NSN and cage codes, refer to cross reference index (WP 0042).

Table 1. Manufactured Items Part Number Index.

ITEM NO.	PART NO.	ITEM	PAGE NO.
1		Drum crate (bottom crate)	WP 0050-2
2		Component crate (top crate)	WP 0050-3
3	RR-C-271	Chain, weldless, bulk	WP 0050-4

ILLUSTRATED LIST OF MANUFACTURED ITEMS (Contd)

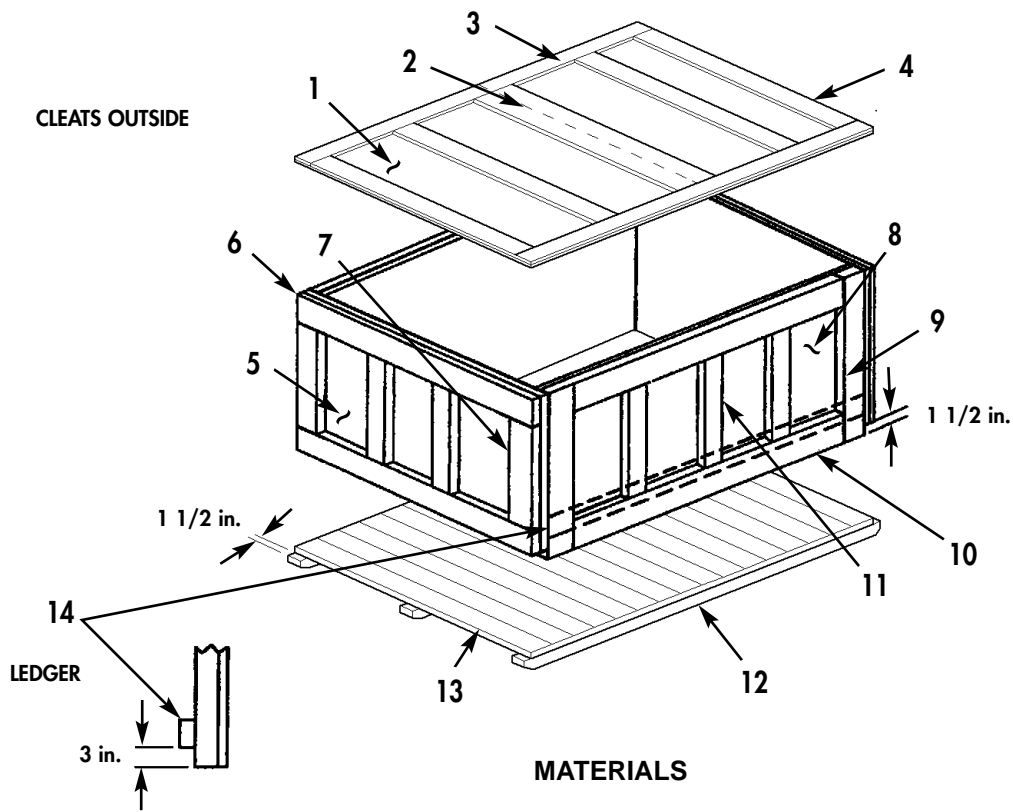

Description

Crate, Shipping, Drum, 86 in. x 69 in. x 41 in. OD

PROCEDURE:
Cutting list.*

FIND	QTY	DIA
1	2 EA	3/4 PLY X 43 X 69
2	1 EA	1 X 8 X 58
3	2 EA	1 X 6 X 86
4	4 EA	1 X 6 X 58
5	2 EA	3/4 PLY X 36 3/4 X 69
6	4 EA	1 X 6 X 69
7	8 EA	1 X 6 X 25 3/4
8	2 EA	3/4 PLY X 38 1/4 X 83
9	4 EA	2 X 6 X 38 1/4
10	4 EA	2 X 6 X 72
11	6 EA	2 X 6 X 27 1/4
12	3 EA	4 X 4 X 86 BEVELED
13	16 EA	2 X 6 X 64 1/2 RIP ONE (1) TO FIT
14	2 EA	2 X 4 X 83 LEDGER FOR SIDES LAG ONE (1) END

*All dimensions in inches.

Figure 1. FAWPSS Drum Crate (Bottom Crate).

ILLUSTRATED LIST OF MANUFACTURED ITEMS (Contd)

TOP SHOWN
INVERTED

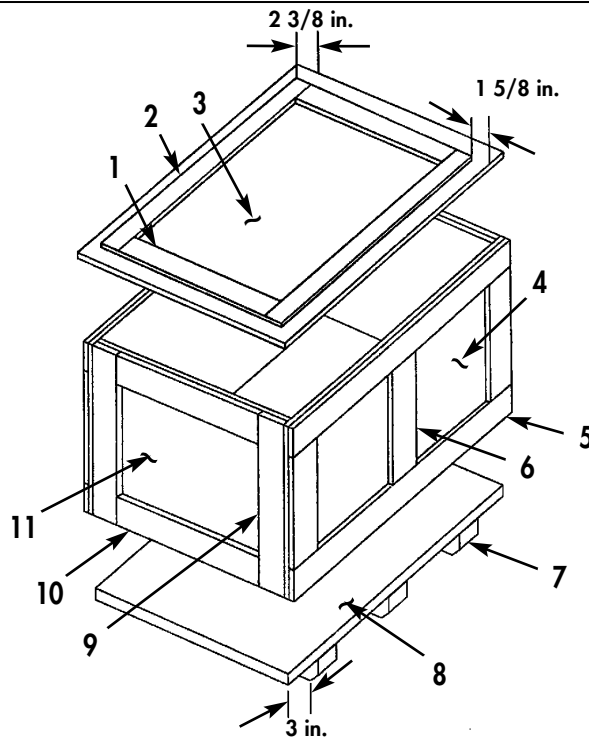

MATERIALS

Description

Crate, Shipping, Component, 69 in. x 45 in. x 39 in. OD

PROCEDURE:
Cutting list.*

FIND	QTY	DIA
TOP (INVERTED)		
1	2	1 X 4 X 34 3/4
2	2	1 X 4 X 64 1/4
3	1	3/4 PLY X 69 X 45
SIDE		
4	2	3/4 PLY X 69 X 35 1/4
5	4	1 X 6 X 69
6	6	1 X 6 X 24 1/2
BASE		
7	3	4 X 4 X 45
8	1	3/4 PLY X 69 X 45
ENDS		
9	4	2 X 6 X 35 /14
10	4	2 X 6 X 31
11	2	3/4 PLY X 42 X 35 1/4

NOTE: LAG ONE SIDE

*All dimensions in inches.

Figure 2. FAWPSS Component Crate (Top Crate).

ILLUSTRATED LIST OF MANUFACTURED ITEMS (Contd)

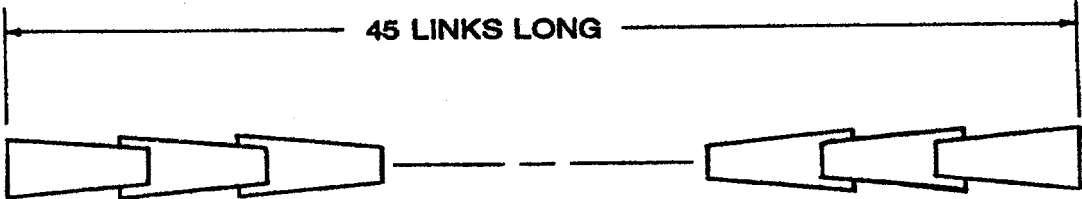

45 LINKS LONG

MATERIALS

<u>Description</u>	<u>NSN</u>
Chain, Sash, Bronze, Trade no. 35 Type II Class 3	4010-00-515-4101

PROCEDURE:
Cut bulk chain to length of 45 links.

Figure 3. Retaining Chain.

**UNIT MAINTENANCE
FORWARD AREA WATER POINT SUPPLY SYSTEM (FAWPSS)
TORQUE LIMITS**

GENERAL**NOTE**

Use standard torque limits when tightening screws that are installed in thread inserts unless noted.

This work package provides general torque limits for screws used on FAWPSS equipment. Special torque limits are indicated within the maintenance tasks for applicable components. The general torque limits given in this work package shall be used when specific torque limits are not indicated in the maintenance task. These general torque limits cannot be applied to screws that retain rubber components. Rubber components will become damaged before the correct torque limit can be reached.

TORQUE TABLES

Table 1 lists dry torque limits. Dry torque limits are used on screws that do not have lubricants applied to the threads. Table 2 lists wet torque limits. Wet torque limits are used on screws that have high pressure lubricants applied to the threads. For metric fasteners, refer to table 3 for torque limit requirements.

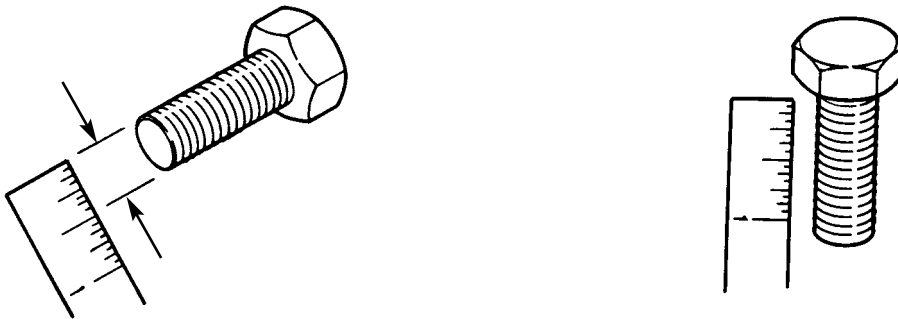
HOW TO USE TORQUE TABLES

1. Measure the diameter of the screw.
2. Count the number of threads per inch.
3. Under the heading **SIZE**, look down the left hand column and find the diameter of the screw. (There will usually be two lines beginning with the same size).
4. In the second column under **SIZE**, find the number of threads per inch that matches the number of threads you counted in step 2 (not required for metric screws).
5. Determine the grade of screw by matching the markings on the head of the screw to the correct picture of **CAPSCREW HEAD MARKINGS** in the illustration preceding the torque limits table.
6. Look down the column under the picture you found in step 5 until you find the torque limit (in lb-ft or N.m) for the diameter and threads per inch of the screw.

CAPSCREW HEAD MARKINGS

<p>Manufacturer's marks may vary. These are all SAE Grade 5 (3-line)</p> <div style="text-align: center;"> </div> <p style="text-align: center;">STANDARD</p>	<p>Metric screws are of three grades: 8.8, 10.9, and 12.9. Grades & Manufacturer's marks appear on the screw head</p> <div style="text-align: center;"> </div> <p style="text-align: center;">METRIC</p>
--	---

TORQUE LIMITS (Contd)

TORQUE LIMITS (Contd)

Table 1. Torque Limits for Dry Fasteners.

SIZE			TORQUE							
			SAE GRADE NO. 1 or 2		SAE GRADE NO. 5		SAE GRADE NO. 6 or 7		SAE GRADE NO. 8	
DIA. INCHES	THREADS PER INCH	DIA. MILLIMETERS	POUND FEET	NEWTON METERS	POUND FEET	NEWTON METERS	POUND FEET	NEWTON METERS	POUND FEET	NEWTON METERS
1/4	20	6.35	5	7	8	11	10	14	12	16
1/4	28	6.35	6	9	10	14	12	16	14	19
5/16	18	7.94	11	15	17	23	21	28	24	33
5/16	24	7.94	12	16	19	26	24	33	27	37
3/8	16	9.53	20	27	30	41	40	54	45	61
3/8	24	9.53	23	31	35	47	45	61	50	68
7/16	14	11.11	30	41	50	68	60	81	70	95
7/16	20		35	47	55	75	70	95	80	108
1/2	13	12.70	50	68	75	102	95	129	110	149
1/2	20		55	75	90	122	100	136	120	163
9/16	12	14.29	65	88	110	149	135	183	150	203
9/16	18		75	102	120	163	150	203	170	231
5/8	11	15.88	90	122	150	203	190	258	220	298
5/8	18		100	136	180	244	210	285	240	325
3/4	10	19.05	160	217	260	353	320	434	380	515
3/4	16		180	244	300	407	360	488	420	597
7/8	9	22.23	140	190	400	542	520	705	600	814
7/8	14		155	210	440	597	580	786	660	895
1	8	25.40	220	298	580	786	800	1085	900	1220
1	12		240	325	640	868	860	1166	1000	1356
1-1/8	7	25.58	300	407	800	1085	1120	1519	1280	1736
1-1/8	12		340	461	880	1193	1260	1709	1440	1953
1-1/4	7	31.75	420	570	1120	1519	1580	2142	1820	2468
1-1/4	12		460	624	1240	1681	1760	2387	2000	2712
1-3/8	6	34.93	560	759	1460	1980	2080	2820	2380	3227
1-3/8	12		640	868	1690	2278	2380	3227	2720	3688
1-1/2	6	38.10	740	1003	1940	2631	2780	3770	3160	4285
1-1/2	12		840	1139	2200	2983	3100	4204	3560	4827

CAPSCREW HEAD MARKINGS



Manufacturer's marks may vary. These are all SAE Grade 5 (3-line).

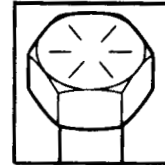
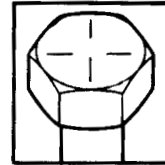
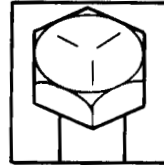
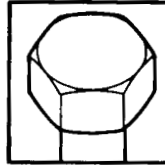

TORQUE LIMITS (Contd)

TORQUE LIMITS (Contd)

Table 2. Torque Limits for Wet Fasteners.

SIZE			TORQUE							
			SAE GRADE NO. 1 or 2		SAE GRADE NO. 5		SAE GRADE NO. 6 or 7		SAE GRADE NO. 8	
DIA. INCHES	THREADS PER INCH	DIA. MILLIMETERS	POUND FEET	NEWTON METERS	POUND FEET	NEWTON METERS	POUND FEET	NEWTON METERS	POUND FEET	NEWTON METERS
1/4	20	6.35	4	6	6	8	8	11	9	12
1/4	28	6.35	5	7	7	9	9	12	10	14
5/16	18	7.94	8	11	13	18	16	22	18	24
5/16	24	7.94	9	12	14	19	18	24	20	27
3/8	16	9.53	15	20	23	31	30	41	40	54
3/8	24	9.53	17	23	25	34	30	41	44	60
7/16	14	11.11	24	33	35	47	45	61	55	75
7/16	20		25	34	40	54	50	68	60	81
1/2	13	12.70	35	47	55	75	70	95	80	108
1/2	20		40	54	65	88	80	108	90	122
9/16	12	14.29	50	68	80	108	100	136	110	149
9/16	18		55	75	90	122	110	149	130	176
5/8	11	15.88	70	95	110	149	140	190	170	231
5/8	18		80	108	130	176	160	217	180	244
3/4	10	19.05	120	163	200	271	240	325	280	380
3/4	16		140	190	220	298	280	380	320	434
7/8	9	22.23	110	149	300	407	400	542	460	624
7/8	14		120	163	320	434	440	597	500	678
1	8	25.40	160	217	440	597	600	814	680	922
1	12		170	231	480	651	660	895	740	1003
1-1/8	7	25.58	220	298	600	814	840	1139	960	1302
1-1/8	12		260	353	660	895	940	1275	1080	1464
1-1/4	7	31.75	320	434	840	1139	1100	1492	1360	1844
1-1/4	12		360	488	920	1248	1320	1790	1500	2034
1-3/8	6	34.93	420	570	1100	1492	1560	2115	1780	2414
1-3/8	12		460	624	1260	1709	1780	2414	2040	2766
1-1/2	6	38.10	560	760	1460	1980	2080	2820	2360	3200
1-1/2	12		620	841	1640	2224	2320	3146	2660	3607

CAPSCREW HEAD MARKINGS



Manufacturer's marks may vary. These are all SAE Grade 5 (3-line).

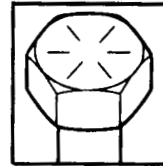
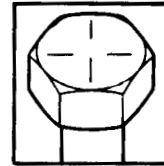
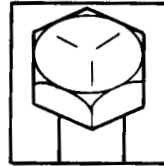
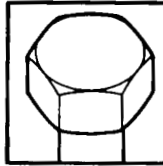

TORQUE LIMITS (Contd)

Table 3. Torque Limits for Metric Fasteners.

SIZE		TORQUE					
		METRIC GRADE 8.8		METRIC GRADE 10.9		METRIC GRADE 12.9	
DIA. INCHES	DIA. MILLIMETERS	POUND FEET	NEWTON METERS	POUND FEET	NEWTON METERS	POUND FEET	NEWTON METERS
.157	4	2	3	3	4	4	5
.197	5	4	5	6	8	7	9
.237	6	7	9	10	14	11	15
.276	7	11	15	16	22	20	27
.315	8	18	24	25	34	29	39
.394	10	32	43	47	64	58	79
.473	12	58	79	83	113	100	136
.552	14	94	127	133	180	159	216
.630	16	144	195	196	266	235	319
.709	18	190	258	269	365	323	438
.788	20	260	353	366	496	440	597
.867	22	368	499	520	705	678	919
.946	24	470	637	664	900	794	1077
1.064	27	707	959	996	1351	1235	1675
1.182	30	967	1311	1357	1840	1630	2210

CAPSCREW HEAD MARKINGS

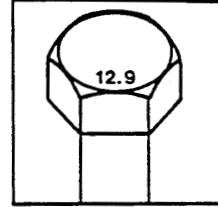
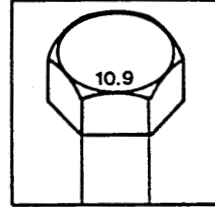
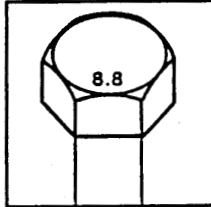

TORQUE WRENCH ADAPTERS

Some maintenance tasks require the use of a torque wrench adapter when the nut or screw cannot be reached with a regular socket on the end of the torque wrench. These adapters add to the overall length of the torque wrench and make the dial or scale reading less than the actual torque applied to the nut or screw. To prevent overtightening and damage to equipment, calculate the correct dial or scale reading using the conversion formula provided; refer to Conversion Formula (on following page).

TORQUE LIMITS (Contd)

CONVERSION FORMULA

Corrected dial or scale readings are determined by the use of the following formula:

$$\text{Corrected reading} = \text{Required torque value} \div \frac{\text{Length of torque wrench} + \text{Length of adapter}}{\text{Length of torque wrench}}$$

NOTE

The length of the torque wrench is measured from the center of the handle to the center of the drive. The length of the adapter is measured from the center of the drive to the center of the wrench.

EXAMPLE:

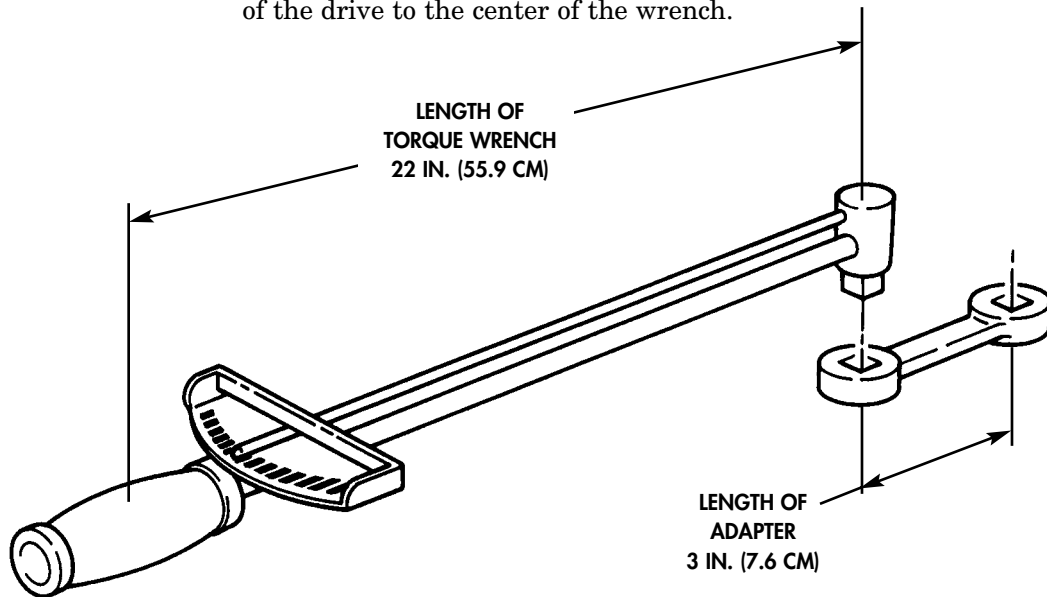

In this example, the torque wrench measures 22 in. (55.9 cm) and the adapter is 3 in. (7.6 cm). The required torque is 19 lb-ft (25.8 N•m)

$$\text{Corrected reading} = 19 \text{ lb-ft (25.8 N}\cdot\text{m)} \div \frac{22 \text{ in. (55.9 cm)} + 3 \text{ in. (7.6 cm)}}{22 \text{ in. (55.9 cm)}}$$

$$\text{Corrected reading} = 19 \text{ lb-ft (25.8 N}\cdot\text{m)} \div \frac{25 \text{ in. (63.5 cm)}}{22 \text{ in. (55.9 cm)}}$$

$$\text{Corrected reading} = 19 \text{ lb-ft (25.8 N}\cdot\text{m)} \div 1.14$$

$$\text{Corrected reading} = 17 \text{ lb-ft (23.1 N}\cdot\text{m)}$$

INDEX

<u>Subject</u>	<u>WP Sequence No.-Page No.</u>
A	
Abbreviation/Acronyms	WP 0001-3
Additional Authorization List	WP 0048-1
Assembly and function of FAWPSS.	WP 0003-2
Assembly and preparation for use.	WP 0005-1
Assembly of FAWPSS, Model LAB 9095	WP 0007-1
Assembly of FAWPSS, Model M105.	WP 0008-1
B	
Ball valve replacement.	WP 0022-1
Basic Issue Items (BII), Component of End Item (COEI) and	WP 0047-1
C	
Characteristics, capabilities, and features, equipment	WP 0002-1
Checking unpacked equipment	WP 0018-4
Cleaning	WP 0028-1
Component of End Item (COEI) and Basic Issue Items (BII) lists	WP 0047-1
Contents, table of	ii
Controls and indicators, description and use of operator	WP 0004-1
Corrosion prevention and control (CPC).	WP 0001-2
Cross-reference list, nomenclature	WP 0001-4
D	
Data, equipment description and	WP 0002-1
Data plates, location and description of	WP 0002-11
Deployment by helicopter.	WP 0009-12
Description and use of controls and indicators.	WP 0004-1
Destruction of Army material to prevent enemy use.	WP 0001-2
Differences between models.	WP 0002-8
Disassembly for movement, model LAB 9095	WP 0010-1
Disassembly for movement, model M105	WP 0011-1
Drums, filling and movement of	WP 0009-1
E	
Equipment characteristics, capabilities, and features	WP 0002-1
Equipment description and data.	WP 0004-1
Expendable and durable items list	WP 0049-1

INDEX (Contd)

<u>Subject</u>	<u>WP Sequence No.-Page No.</u>
F	
Filling and movement of drums	WP 0009-1
Forms, records, and reports, maintenance	WP 0001-1
Function of the drum	WP 0003-1
Function of the pump unit	WP 0003-1
G	
General	
Maintenance	WP 0028-1
Information	WP 0001-1
Introduction to troubleshooting, field	WP 0030-1
Introduction to troubleshooting, operator	WP 0014-1
Lubrication instructions	WP 0016-1
Operation under unusual conditions	WP 0012-1
Theory of operation	WP 0003-1
H	
Hand receipt	WP 0001-2
Helicopter, deployment by	WP 0000-1
Hose assembly maintenance	WP 0021-1
How to use this manual	v
I	
Illustrated list of manufactured items	WP 0050-1
Indicators, description and use of operator controls and	WP 0004-1
Information, general	WP 0001-1
Introduction, parts information	WP 0031-1
Introduction to	
Troubleshooting, operator	WP 0014-1
Troubleshooting, unit	WP 0030-1
L	
List of	
Abbreviations/acronyms	WP 0001-3
Effective pages	A/B blank
Loading and movement of equipment	WP 0028-2
Location and description of data plates	WP 0002-11
Location and description of major component	WP 0002-3
Location of Basic Issue Items (BII), Components of End Item (COEI), and Additional Authorization List (AAL) items	WP 0000-1
Lubrication instructions	WP 0016-1

INDEX (Contd)

Subject **WP Sequence No.-Page No.**

M

Maintenance Allocation Chart (MAC) introduction WP 0045-1
 Maintenance Allocation Chart (MAC) WP 0046-1
 Maintenance forms, records, and reports WP 0001-1
 Maintenance, general WP 0028-1
 Maintenance, operator WP 0017-1
 Manual, how to use this v
 Miscellaneous fittings maintenance WP 0026-1
 Movement of drums, filling and WP 0009-1

N

National Stock Number (NSN) index WP 0042-1
 Nozzle assembly maintenance WP 0023-1
 Nozzle stand assembly maintenance WP 0024-1
 Nomenclature cross reference list WP 0001-3

O

Operation in extreme heat or dry conditions WP 0012-2
 Operation in high wind conditions WP 0012-3
 Operation in rainy or humid conditions WP 0012-4
 Operation in snow or icy conditions WP 0012-1
 Operation, theory of WP 0003-1
 Operation under unusual conditions WP 0012-1
 Operation under usual conditions WP 0005-1
 Operation, theory of WP 0003-1
 Operator controls and indicators, description and use of WP 0004-1
 Operator Preventive Maintenance Checks and Services
 (PMCS) introduction WP 0019-1
 Operator Preventive Maintenance Checks and Services
 (PMCS) and lubrication instructions WP 0020-1
 Ozone Depleting Substances (ODS) WP 0001-2

P

Painting WP 0045-2
 Part number index WP 0043-1
 Preparation for shipment and limited storage WP 0028-3
 Preparation for storage of equipment WP 0001-3
 Preventive Maintenance Checks and Service (PMCS),
 Introduction, operator WP 0015-1
 Introduction, Field WP 0019-1

INDEX (Contd)

Subject

WP Sequence No.-Page No.

P (Contd)

Preventive Maintenance Checks and Service (PMCS) and
lubrication instructions

Introduction, operator WP 0016-1

Introduction, unit WP 0020-1

R

Receipt of material, service upon. WP 0018-1

Receipt, hand. WP 0001-2

References WP 0044-1

Reporting Equipment Improvement Recommendations (EIR) WP 0001-2

Reports, maintenance forms, records, and WP 0001-1

S

Service upon receipt of material WP 0018-1

Shipment and limited storage, preparation for WP 0028-3

Storage of equipment, preparation for WP 0001-3

Site requirements and layouts. WP 0006-1

Supporting information for repair parts, special tools, TMDE,
and support equipment WP 0001-3

T

Table of contents. ii

Theory of operation. WP 0003-1

Tiedown assemblies maintenance WP 0027-1

Troubleshooting index

Operator WP 0013-1

Unit WP 0029-1

Troubleshooting procedures

Operator WP 0014-1

Unit WP 0030-1

Torque limits. WP 0051-1

Towing and lifting yoke maintenance WP 0025-1

INDEX (Contd)

<u>Subject</u>	<u>WP Sequence No.-Page No.</u>
U	
Use of operator controls and indicators, description and	WP0004-1
Unit Preventive Maintenance Checks and Services (PMCS) introduction	WP 0019-1
Unit Preventive Maintenance Checks and Services (PMCS) and lubrication instructions	WP 0020-1
Unit Troubleshooting Index	WP 0029-1
Unit Troubleshooting Procedures	WP 0030-1
W	
Warning summary	warning a

By Order of the Secretary of the Army:

Official:



JOYCE E. MORROW

*Administrative Assistant to the
Secretary of the Army*

0705803

PETER J. SCHOOMAKER
*General, United States Army
Chief of Staff*

Distribution:

To be distributed in accordance with the initial distribution number (IDN) 256049,
requirements for TM 10-4320-346-12&P.

RECOMMENDED CHANGES TO PUBLICATIONS AND BLANK FORMS For use of this form, see AR 25-30; the proponent agency is ODISC4.	Use Part II (reverse) for Repair Parts and Special Tools Lists (RPSTL) and Supply Catalogs/Supply Manuals (SC/SM).	DATE: (Date form is filled out)
---	--	------------------------------------

TO: <i>(Forward to proponent of publication or form) (include ZIP code)</i> AMSTA-LC-LPIT Tech Pubs, TACOM-RI 1 Rock Island Arsenal Rock Island, IL 61299-7630	FROM: <i>(Activity and location) (include ZIP code)</i> (Your mailing address)
--	---

PART I - ALL PUBLICATIONS (EXCEPT RPSTL AND SC/SM) AND BLANK FORMS

PUBLICATION/FORM NUMBER TM 10-4320-346-12&P	DATE (Date of Publication)	TITLE OPERATOR AND UNIT MAINTENANCE MANUAL INCLUDING REPAIR PARTS AND SPECIAL TOOLS LIST (RPSTL) FOR FORWARD AREA WATER POINT SUPPLY SYSTEM (FAWPSS)
---	-------------------------------	--

ITEM NO.	PAGE NO.	PARA-GRAPH	LINE NO.*	FIGURE NO.	TABLE NO.	RECOMMENDED CHANGES AND REASON <i>(Provide exact wording of recommended changes, if possible)</i>
12	0008-4			5		Callout to pump discharge port reads (Figure 5, Item 1). Should read (Figure 5, Item 3).

SAMPLE

**Reference to line numbers within the paragraph or subparagraph.*

TYPED NAME, GRADE, OR TITLE Doe, John, CPL	TELEPHONE EXCHANGE/AUTOVON, PLUS EXTENSION (734) 523-8904	SIGNATURE CPL John Doe
--	---	----------------------------------

TO: <i>(Forward direct to addressee listed in publication)</i> AMSTA-LC-LPIT Tech Pubs, TACOM-RI 1 Rock Island Arsenal Rock Island, IL 61299-7630	FROM: <i>(Activity and location) (include ZIP code)</i> (Your mailing address)	DATE: (Date form is filled out)
--	---	--

PART II - REPAIR PARTS AND SPECIAL TOOLS LISTS AND SUPPLY CATALOGS/SUPPLY MANUALS

PUBLICATION/FORM NUMBER TM 10-4320-346-12&P	DATE (Date of Publication)	TITLE OPERATOR AND UNIT MAINTENANCE MANUAL INCLUDING REPAIR PARTS AND SPECIAL TOOLS LIST (RPSTL) FOR FORWARD AREA WATER POINT SUPPLY SYSTEM (FAWPSS)
--	-----------------------------------	--

PAGE NO.	COLM NO.	LINE NO.	NATIONAL STOCK NUMBER	REFERENCE NO.	FIGURE NO.	ITEM NO.	TOTAL NO. OF MAJOR ITEMS SUPPORTED	RECOMMENDED ACTION
0033-1	5	5	5330-00-612-2414		2	5		Item number 5 reads part number 5888H. Should read 5388H.

SAMPLE

PART III - REMARKS *(Any general remarks or recommendations, or suggestions for improvement of publications and blank forms. Additional blank sheets may be used if more space is needed.)*

TYPED NAME, GRADE, OR TITLE Doe, John, CPL			TELEPHONE EXCHANGE/AUTOVON, PLUS EXTENSION (734) 523-8904			SIGNATURE CPL John Doe		
---	--	--	---	--	--	-------------------------------	--	--

RECOMMENDED CHANGES TO PUBLICATIONS AND BLANK FORMS For use of this form, see AR 25-30; the proponent agency is ODISC4.						Use Part II (<i>reverse</i>) for Repair Parts and Special Tool Lists (RPSTL) and Supply Catalogs/Supply Manuals (SC/SM).	DATE
TO: (<i>Forward to proponent of publication or form</i>) (<i>Include ZIP Code</i>) AMSTA-LC-LPIT / TECH PUBS, TACOM-RI 1 Rock Island Arsenal Rock Island, IL 61299-7630						FROM: (<i>Activity and location</i>) (<i>Include ZIP Code</i>)	
PART I - ALL PUBLICATIONS (EXCEPT RPSTL AND SC/SM) AND BLANK FORMS							
PUBLICATION/FORM NUMBER TM 10-4320-346-12&P						DATE 16 March 2007	TITLE FORWARD AREA WATER POINT SUPPLY SYSTEM (FAWPSS)
ITEM NO.	PAGE NO.	PARA-GRAPH	LINE NO. *	FIGURE NO.	TABLE NO.	RECOMMENDED CHANGES AND REASON <i>(Provide exact wording of recommended changes, if possible).</i>	
<i>*Reference to line numbers within the paragraph or subparagraph.</i>							
TYPED NAME, GRADE OR TITLE				TELEPHONE EXCHANGE/AUTOVON, PLUS EXTENSION		SIGNATURE	

TO: <i>(Forward direct to addressee listed in publication)</i> AMSTA-LC-LPIT / TECH PUBS, TACOM-RI 1 Rock Island Arsenal Rock Island, IL 61299-7630	FROM: <i>(Activity and location) (Include ZIP Code)</i>	DATE
--	---	------

PART II – REPAIR PARTS AND SPECIAL TOOL LISTS AND SUPPLY CATALOGS/SUPPLY MANUALS

PUBLICATION NUMBER TM 10-4320-346-12&P				DATE 16 March 2007			TITLE FORWARD AREA WATER POINT SUPPLY SYSTEM (FAWPSS)	
PAGE NO.	COLM NO.	LINE NO.	NATIONAL STOCK NUMBER	REFERENCE NO.	FIGURE NO.	ITEM NO.	TOTAL NO. OF MAJOR ITEMS SUPPORTED	RECOMMENDED ACTION

PART III – REMARKS *(Any general remarks or recommendations, or suggestions for improvement of publications and blank forms. Additional blank sheets may be used if more space is needed.)*

--

TYPED NAME, GRADE OR TITLE	TELEPHONE EXCHANGE/AUTOVON, PLUS EXTENSION	SIGNATURE
----------------------------	--	-----------

RECOMMENDED CHANGES TO PUBLICATIONS AND BLANK FORMS For use of this form, see AR 25-30; the proponent agency is ODISC4.						Use Part II (<i>reverse</i>) for Repair Parts and Special Tool Lists (RPSTL) and Supply Catalogs/Supply Manuals (SC/SM).	DATE
TO: (<i>Forward to proponent of publication or form</i>) (<i>Include ZIP Code</i>) AMSTA-LC-LPIT / TECH PUBS, TACOM-RI 1 Rock Island Arsenal Rock Island, IL 61299-7630						FROM: (<i>Activity and location</i>) (<i>Include ZIP Code</i>)	
PART I - ALL PUBLICATIONS (EXCEPT RPSTL AND SC/SM) AND BLANK FORMS							
PUBLICATION/FORM NUMBER TM 10-4320-346-12&P						DATE 16 March 2007	TITLE FORWARD AREA WATER POINT SUPPLY SYSTEM (FAWPSS)
ITEM NO.	PAGE NO.	PARA-GRAPH	LINE NO. *	FIGURE NO.	TABLE NO.	RECOMMENDED CHANGES AND REASON <i>(Provide exact wording of recommended changes, if possible).</i>	
<i>*Reference to line numbers within the paragraph or subparagraph.</i>							
TYPED NAME, GRADE OR TITLE				TELEPHONE EXCHANGE/AUTOVON, PLUS EXTENSION		SIGNATURE	

TO: <i>(Forward direct to addressee listed in publication)</i> AMSTA-LC-LPIT / TECH PUBS, TACOM-RI 1 Rock Island Arsenal Rock Island, IL 61299-7630	FROM: <i>(Activity and location) (Include ZIP Code)</i>	DATE
--	---	------

PART II - REPAIR PARTS AND SPECIAL TOOL LISTS AND SUPPLY CATALOGS/SUPPLY MANUALS

PUBLICATION NUMBER TM 10-4320-346-12&P	DATE 16 March 2007	TITLE FORWARD AREA WATER POINT SUPPLY SYSTEM (FAWPSS)
---	-----------------------	--

PAGE NO.	COLM NO.	LINE NO.	NATIONAL STOCK NUMBER	REFERENCE NO.	FIGURE NO.	ITEM NO.	TOTAL NO. OF MAJOR ITEMS SUPPORTED	RECOMMENDED ACTION

PART III - REMARKS *(Any general remarks or recommendations, or suggestions for improvement of publications and blank forms. Additional blank sheets may be used if more space is needed.)*

--

TYPED NAME, GRADE OR TITLE	TELEPHONE EXCHANGE/AUTOVON, PLUS EXTENSION	SIGNATURE
----------------------------	--	-----------

STANDARD AND METRIC CONVERSIONS

LINEAR MEASURE

- 1 Centimeter = 10 Millimeters = 0.01 Meters = 0.3937 Inches
- 1 Meter = 100 Centimeters = 1,000 Millimeters = 39.37 Inches
- 1 Kilometer = 1,000 Meters = 0.621 Miles

SQUARE MEASURE

- 1 Sq Centimeter = 100 Sq Millimeters = 0.155 Sq Inches
- 1 Sq Meter = 10,000 Sq Centimeters = 10.76 Sq Feet
- 1 Sq Kilometer = 1,000,000 Sq Meters = 0.386 Sq Miles

CUBIC MEASURE

- 1 Cu Centimeter = 1,000 Cu Millimeters = 0.06 Cu Inches
- 1 Cu Meter = 1,000,000 Cu Centimeters = 35.31 Cu Feet

LIQUID MEASURE

- 1 Milliliter = 0.001 Liters = 0.0338 Fluid Ounces
- 1 Liter = 1,000 Milliliters = 33.82 Fluid Ounces

TEMPERATURE

- Degrees Fahrenheit (F) = $^{\circ}\text{C} \cdot 9 \div 5 + 32$
- Degrees Celsius (C) = $\text{F}^{\circ} - 32 \cdot 5 \div 9$
- 212° Fahrenheit is equivalent to 100° Celsius
- 90° Fahrenheit is equivalent to 32.2° Celsius
- 32° Fahrenheit is equivalent to 0° Celsius

WEIGHTS

- 1 Gram = 0.001 Kilograms = 1,000 Milligrams = 0.035 Ounces
- 1 Kilogram = 1,000 Grams = 2.2 Lb
- 1 Metric Ton = 1,000 Kilograms = 1 Megagram = 1.1 Short Tons

APPROXIMATE CONVERSION FACTORS

TO CHANGE	TO	MULTIPLY BY
Inches	Millimeters	25.400
Inches	Centimeters	2.540
Feet	Meters	0.305
Yards	Meters	0.914
Miles	Kilometers	1.609
Square Inches	Square Centimeters	6.451
Square Feet	Square Meters	0.093
Square Yards	Square Meters	0.836
Square Miles	Square Kilometers	2.590
Acres	Square Hectometers	0.405
Cubic Feet	Cubic Meters	0.028
Cubic Yards	Cubic Meters	0.765
Fluid Ounces	Milliliters	29.573
Pints	Liters	0.473
Quarts	Liters	0.946
Gallons	Liters	3.785
Ounces	Grams	28.349
Pounds	Kilograms	0.4536
Short Tons	Metric Tons	0.907
Pound-Feet	Newton-Meters	1.356
Pounds Per Square Inch	Kilopascals	6.895
Miles Per Gallon	Kilometers Per Liter	0.425
Miles Per Hour	Kilometers Per Hour	1.609
TO CHANGE	TO	MULTIPLY BY
Millimeters	Inches	0.03937
Centimeters	Inches	0.3937
Meters	Feet	3.280
Meters	Yards	1.094
Kilometers	Miles	0.621
Square Centimeters	Square Inches	0.155
Square Meters	Square Feet	10.764
Square Meters	Square Yards	1.196
Square Kilometers	Square Miles	0.386
Square Hectometers	Acres	2.471
Cubic Meters	Cubic Feet	35.315
Cubic Meters	Cubic Yards	1.308
Milliliters	Fluid Ounces	0.034
Liters	Pints	2.113
Liters	Quarts	1.057
Liters	Gallons	0.264
Grams	Ounces	0.035
Kilograms	Pounds	2.2046
Metric Tons	Short Tons	1.102
Newton-Meters	Pound-Feet	0.738
Kilopascals	Pounds Per Square Inch	0.145
Kilometers Per Liter	Miles Per Gallon	2.354
Kilometers Per Hour	Miles Per Hour	0.621

